

Rapid extraction of dissolved inorganic carbon from seawater and groundwater samples for radiocarbon dating

K. Gospodinova,* A. P. McNichol, A. Gagnon, S. R. Shah Walter

National Ocean Sciences Accelerator Mass Spectrometry Facility, Geology and Geophysics Department, Woods Hole Oceanographic Institution, Woods Hole, Massachusetts

Abstract

We designed and developed a system to efficiently extract dissolved inorganic carbon (DIC) from seawater and groundwater samples for radiocarbon dating. The Rapid Extraction of Dissolved Inorganic Carbon System (REDICS) utilizes a gas-permeable polymer membrane contactor to extract the DIC from an acidified water sample in the form of carbon dioxide (CO₂), introduce it to a helium gas stream, cryogenically isolate it, and store it for stable and radiocarbon isotope analysis. The REDICS system offers multiple advantages to the DIC extraction method which has been used for the last several decades at the National Ocean Sciences Accelerator Mass Spectrometry Facility (NOSAMS) at the Woods Hole Oceanographic Institution, including faster DIC extraction, streamlined analysis, and minimized set-up and prep time. The system was tested using sodium carbonate and seawater standards, duplicates of which were also processed on the water stripping line (WSL) at NOSAMS. The results demonstrate that the system successfully extracts, quantifies, and stores more than 99% of the DIC in less than 20 min. Stable and radiocarbon isotope analysis demonstrated system precision of 0.04‰ and 7.8‰, respectively. A Sargasso Sea depth profile was used to further validate the system. The results show high precision for both stable and radiocarbon analysis with pooled standard deviations of 0.02‰ and 5.6‰, respectively. A comparison between the REDICS and WSL analyses indicates a good accuracy for both stable and radio-isotope analysis.

Since the start of the Industrial Revolution roughly 40% of the anthropogenic carbon dioxide (CO₂) has remained in the atmosphere, increasing CO₂ concentration by about 100 parts-per-million, and another 30% has been absorbed by the oceans (Doney et al. 2009). The input of CO₂ to the atmosphere is contributing to global warming while abiotic absorption by the ocean is resulting in ocean acidification. The rate of both of these effects is predicted to increase substantially over the next century (Doney et al. 2009). Recent work has indicated that for accurate characterization of these effects the ocean cannot be thought of as a simple global sink for CO₂ because of the complexity of the dissolved CO₂ system (Sabine et al. 2004). To reliably determine the distribution of the anthropogenic CO₂ several processes need to be well understood: CO₂ transfer across the sea surface—air interface, ocean circulation and mixing, and the “biological pump,” namely the transfer of organic carbon synthesized at the surface to the

ocean bottom, reoxidization to inorganic carbon, and circulation back to the surface. The spatial and temporal changes of these processes are not well characterized, and geochemical tracers such as the radiocarbon content of dissolved inorganic carbon (DI¹⁴C) can be used to study and quantify them (Peng et al. 1997).

In 1988, the World Climate Research Programme initiated the World Ocean Circulation Experiment (WOCE) hydrographic survey program (1988–1998) to help understand the role ocean circulation plays in climate variability, improve the understanding of physical processes in the ocean, and advance models for ocean climate predictions (Joyce 1988; <http://www.clivar.org/>). One of the techniques the program used to study the ocean currents was the tracing of components such as DI¹⁴C, temperature, salinity, nutrients, and freons via thousands of samples collected in various locations from the world's oceans (McNichol et al. 2000). The National Ocean Sciences Accelerator Mass Spectrometry Facility (NOSAMS) carried out stable and radioisotope analysis of the dissolved inorganic carbon (DI¹³C, DI¹⁴C, respectively) of 13,000 WOCE samples. The samples were processed on the NOSAMS' water stripping line (WSL), which was designed and built in 1992 (McNichol et al. 1994). The results provided

*Correspondence: kgospodinova@whoi.edu

This is an open access article under the terms of the Creative Commons Attribution-NonCommercial License, which permits use, distribution and reproduction in any medium, provided the original work is properly cited and is not used for commercial purposes.

important constraints to general ocean circulation models and are continuing to show insights into ocean processes (McNichol et al. 2000; Kortzinger et al. 2003; Key et al. 2004; Quay et al. 2007; Graven et al. 2012; Kumamoto et al. 2013; Ko et al. 2014). After the WOCE program was completed, NOSAMS continued to process water samples for the Climate Variability and Predictability program (CLIVAR), which was started in 1995 to understand interannual, decadal, and longer periods of climate variability. The facility has processed over 28,000 samples to date, which is the world's largest homogeneous full precision radiocarbon dataset.

The WSL was designed specifically to facilitate the WOCE and subsequently, the CLIVAR programs. However, since the completion of WOCE, the NOSAMS facility has broadened its service to include groundwater sample analysis, which presents challenges for the current WSL including hard to adapt noncustom collection bottles and a wide range of DIC concentrations. Other improvements such as shorter processing time, reduced use of custom glassware, and an improved ability to subsample bottles are also desirable. Recently, two other laboratories have developed headspace extraction methods designed to streamline the analysis of DI^{14}C in seawater and groundwater (Molnár et al. 2013; Gao et al. 2014). However, these methods cannot meet the requirements of the CLIVAR program for either radiocarbon precision (Molnár et al. 2013) or stable carbon accuracy and precision (Gao et al. 2014).

The Rapid Extraction of Dissolved Inorganic Carbon System (REDICS) was designed to address the limitations of the WSL while still providing the high precision measurements achieved by the WSL, namely better than 0.03–0.05‰ for stable isotope analysis, and 3–4‰ for radiocarbon analysis (Elder et al. 1998; McNichol et al. 2000). The efficiency REDICS offers is largely due to utilizing a novel DIC extraction method. While the WSL uses a time-consuming sparging technique to extract the sample DIC as CO_2 , REDICS uses an optimized gas-permeable polymer membrane contactor, through which CO_2 quickly evolves from an acidified sample. Membrane contactors have been used before to study seawater carbonate chemistry, in particular the partial pressure of CO_2 ($p\text{CO}_2$) and seawater DIC (Hales et al. 2004; Bandstra et al. 2006; Santos et al. 2012). In these studies, a membrane contactor is used to facilitate the extraction of CO_2 from a continuously flowing stream of seawater and into a carrier gas stream. The CO_2 is then continuously quantified using a nondispersive infrared (NDIR) detector. REDICS utilizes the principles used by these studies; however, it has the additional capability of trapping and storing the extracted CO_2 .

Method

The REDICS system was designed to take advantage of the ability of a membrane contactor to rapidly extract CO_2 from solution. A system built around a membrane was attractive

because it allowed us to reduce the size of the sample required, rely on commercially available components and not specially designed glassware, and streamline the sample handling prior to analysis.

The REDICS system extracts the DIC from water samples by recirculating the acidified sample through a closed loop which includes the membrane contactor. The CO_2 gas is then selectively extracted from the water sample through the membrane contactor and into a carrier gas. The extraction rate was optimized by adjusting the recirculating speed and carrier gas flow rates to best match the membrane contactor's requirements for optimal performance. The closed loop volume of 45.5 mL we decided on allows for a wide range of DIC samples to be analyzed. The system is also modular; the volume can be easily increased for samples with low concentration of DIC.

Once extracted, the CO_2 gas is cryogenically trapped, while the carrier gas is removed. The CO_2 is then evolved, quantified, and transferred for stable and radiocarbon analysis. The line is built compactly allowing these processes to be shortened as much as possible.

Theory

Polymer membrane technology has been commercially available since the 1980s (Sridha et al. 2007). Since then, there has been significant progress made toward improving the chemical and physical properties of polymer membranes as well as optimizing their design to improve performance. The membrane contactor we chose to use in the REDICS system is Liqui-Cel's Micromodule G591. This contactor consists of 50 micro-porous polypropylene hollow fibers combined into an array. This geometry gives it a large surface area which increases the gas flow capacity across the membrane. The polypropylene fibers are hydrophobic and create a gas/liquid interface that does not allow easy aqueous penetration through the fiber pores.

The gas extraction driving force used by the Liqui-Cel contactors is the partial pressure differential between the gas and liquid phases. The contactors act as an interface between the two phases and facilitate the mass transfer between them. Since REDICS uses a sweep gas that constantly removes CO_2 from the gas phase, there is a continuous mass transfer of CO_2 from the liquid side to the gas side. The transfer efficiency for the Micromodule has been determined experimentally by measuring percent oxygen extracted from a water stream at different water flow rates. The total amount of removed oxygen decreases with faster fluid velocities and varies linearly between 80% and 62% for speeds between 10 mL min^{-1} and 30 mL min^{-1} (Liqui-Cel, Micromodule Data Sheet). However, the REDICS system recirculates the acidified sample in a closed 45.5 mL loop and through the membrane until the CO_2 is fully extracted, making the fastest fluid velocity of 30 mL min^{-1} the most efficient choice for the extraction.

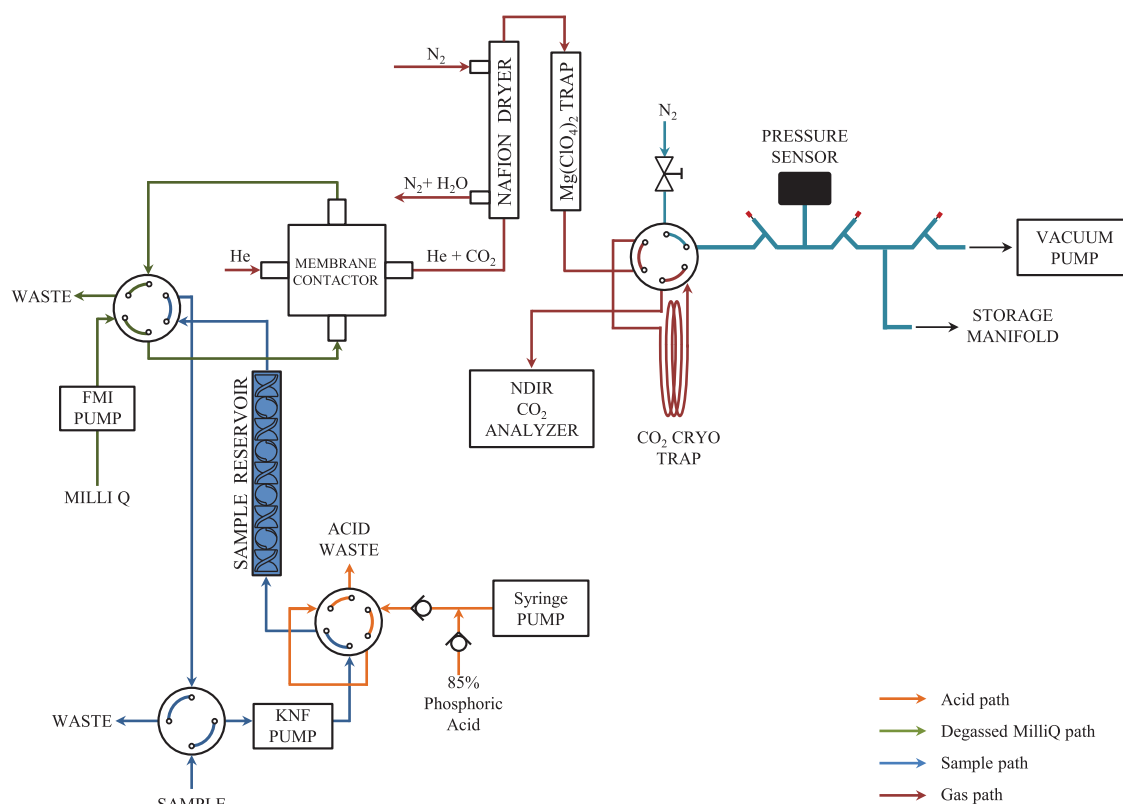

Fig. 1. Schematic of the REDICS system. KNF micro-diaphragm pump is used to draw the sample from the storage bottle at 30 mL min^{-1} and push it through the 45.5 mL sample loop, which consists of peek tubing, three Valco Cheminert valves and a sample reservoir. Once filled, the sample loop is isolated by the four-port Valco Cheminert valve and the sample is continuously circulated by the KNF pump. A syringe pump is used to load the acid loop with 85% phosphoric acid and a FMI pump is used to load the membrane loop with degassed MilliQ water. Two six-port Valco Cheminert valves are used to incorporate the acid and membrane loops to the sample loop. The sample reservoir is equipped with a static stirrer to accommodate fast sample acidification. Helium carrier gas strips the evolved CO_2 from the membrane contactor. The gas is then dried by a Perma-Pure Nafion dryer and a magnesium perchlorate water trap. The CO_2 is extracted from the carrier gas by a liquid-nitrogen cryogenic trap. The carrier gas is finally passed through a Sable Systems NDIR detector to verify successful CO_2 trapping. The sample CO_2 is expanded in a known volume and a MKS Baratron pressure gauge is used to quantify the sample, which is then stored in a glass manifold for further processing.

System description and operation

A schematic of the REDICS system is shown in Fig. 1. The sample of interest is introduced to the system using a KNF micro-diaphragm liquid pump which draws the sample from the sample storage bottle at a flow rate of 30 mL min^{-1} . The sample is pumped through a sample loop, which consists of several components—peek tubing, a Valco Cheminert four port valve, the KNF pump, a Valco Cheminert six-port valve, a static mixer sample reservoir, and another Valco Cheminert six-port valve. REDICS is designed to analyze 45.5 mL of each water sample. Since sample volumes vary between 250 mL and 500 mL, some of the sample is used to purge the system prior to analysis. This is accomplished using the four-port Valco valve in its initial position which allows the sample to flow freely to waste. When the valve is switched later on, it isolates the part of the sample which is to be analyzed in a closed loop.

The two six-port Valco valves are used to introduce 85% phosphoric acid and the membrane contactor to the closed

sample loop after it has been loaded with the sample. The acid and membrane loops are loaded at the same time as the sample loop and are added once the sample loop is isolated and the sample is recirculating. A syringe pump, connected to one of the six-port valves, fills a 0.5 mL loop of peek tubing with acid. In the six-port valve's initial position, the acid loop is isolated from the sample loop, and when the valve is switched, the acid becomes part of the sample loop. Thus the acid addition increases the sample loop volume; however, it does not change the sample loop pressure. Analogously, an FMI displacement pump, connected to the second six-port Valco valve, fills a loop of peek tubing containing the membrane contactor with degassed MilliQ water. When all three loops are loaded, the six-port Valco valves are used to combine them into one closed loop, acidifying the sample, and starting the extraction. A static mixer in the sample reservoir, where most of the sample is contained, allows for efficient sample acidification by ensuring thorough mixing of the acid with the sample. The static mixer is custom

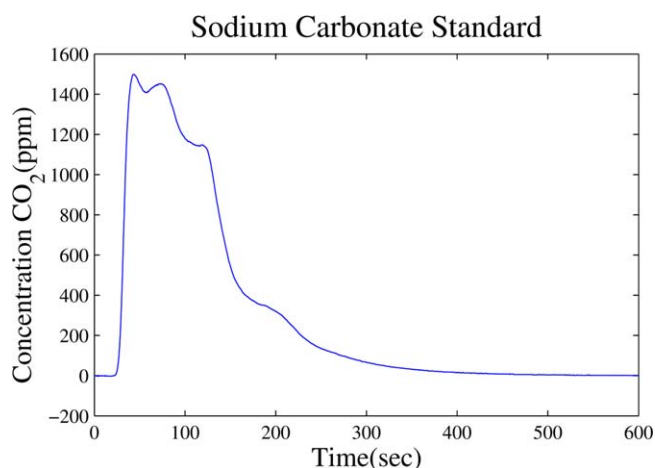

Fig. 2. NDIR CO₂ extraction data for 1.7 mM sodium carbonate standard.

made, consisting of a hollow cylinder housing made out of peek and a polypropylene helical mixing insert from StaMixCo LLC (Fig. 1).

REDICS uses ultrapure helium as a sweep gas, which is passed through an ascarite trap to ensure it is fully free of CO₂ before it enters the membrane contactor. The helium stream removes the extracted CO₂ from the membrane contactor at a flow rate of approximately 300 mL min⁻¹. Immediately downstream from the contactor, the gas stream is stripped of water vapor when it passes through either a Perma Pure Nafion unit reinforced in series with a magnesium perchlorate water trap, or a cryogenic water trap. After exiting the water trap, the sweep gas is passed through another six-port Valco valve and a thin-walled stainless steel multiloop liquid nitrogen trap which efficiently strips the CO₂ from the carrier stream. The CO₂-free helium gas is then passed through a Sable Systems NDIR CO₂ analyzer to ensure all of the extracted CO₂ is fully captured by the liquid nitrogen trap. The NDIR analyzer is controlled using custom LabVIEW software. Once the sample's CO₂ has been collected in the liquid nitrogen trap, the Valco valve is used to isolate the trap from the carrier gas path and introduce it to a vacuum line, constructed of glass tubing and stainless steel ultratorr connections. The line includes several components—a quantification region of known volume, equipped with a thermocouple and a Baratron pressure gauge, isolation Chemglass standard bore valves, a storage manifold, consisting of finger flasks, and an Alcatel high vacuum pumping system. Once the liquid nitrogen trap is added to the vacuum line, the excess helium carrier gas is pumped away. A Chemglass standard bore valve is used to isolate a quantification region of 38.4 mL, which includes the liquid nitrogen trap and the Baratron pressure gauge. The liquid nitrogen dewar is then removed from the trap, allowing the CO₂ gas to thaw and expand in the quantification region.

Once equilibrated, the sample is quantified using the ideal gas law with the obtained pressure and temperature readings. It is then cryogenically transferred to a storage finger flask, and isolated from the system with a Chemglass standard bore valve for further processing.

Results and discussion

The REDICS system was tested and validated using a series of sodium carbonate, seawater, and groundwater standards as well as a depth profile from the Sargasso Sea.

Extraction time

The REDICS system analyzes 45.5 mL of each water sample by recirculating it at 30 mL min⁻¹ through the combined sample, acid and membrane loops. At this speed, the membrane contactor, which is a part of the membrane loop, extracts dissolved gases with 62% efficiency. Thus it can be calculated that, for a fully acidified sample, it would take 7.5 min of recirculation for 99% of CO₂ to be extracted. However, in the REDICS system's set-up, the acidification of the sample and the extraction of the liberated CO₂, happen simultaneously. Specifically the mixing of the sample with the acid is accomplished by passing the sample through the static stirrer. While the mixing is occurring, the sample is being circulated through the membrane, allowing for the evolved CO₂ to be extracted. As those two processes are occurring at the same time, the actual time it takes for the sample to be acidified and fully liberated of all CO₂ needed to be determined experimentally. Five sodium carbonate standards with varying concentrations from 0.5 mM to 4.1 mM were used to determine REDICS' total extraction time. For these tests, the liquid nitrogen trap was not used, allowing the CO₂ and carrier gas to flow through the NDIR analyzer. The NDIR data showed that each standard produced a similar peak. The peak shape is indicative of how the acid and sample are mixing by passing through the static mixer while being recirculated (Fig. 2). The peaks were integrated using trapezoidal integration with varying end point to determine how long it took for 99% of the sample's CO₂ to evolve through the membrane. It was determined that for all samples 99.9% of the sample's DIC was successfully extracted in under 10 min.

System processing blank

The REDICS system processing blank was determined by analyzing eight degassed MilliQ samples following the procedure described above. The CO₂, extracted from each sample, was consecutively stored in the same finger flask to provide enough carbon for stable and radiocarbon isotope analyses. The total CO₂ was then transferred to the NOSAMS' ultra-small line (Shah Walter et al. 2015), where it was quantified, split in two aliquots for stable and radiocarbon analyses, and one of the splits was graphitized. Quantification demonstrated that the blank is small, 0.08 μmols or <0.08% of the

Table 1. Blank effect on minimum sample size, given standard seawater DIC concentration of 2 mmol kg^{-1} .

	CO_2 (μmols)	Seawater volume (mL)
$\delta^{13}C$	44.00	21.46
$\Delta^{14}C$	2.53	1.23

Table 2. System blank comparison, REDICS vs. WSL.

System	%C of ave sample	$\delta^{13}C_{\text{‰}}$	$\Delta^{14}C_{\text{‰}}$
REDICS	0.082	-28.154	-769.0
WSL	0.066	-12.768	-75.5

typical seawater samples processed at NOSAMS. We obtained stable and radiocarbon isotope values of $\delta^{13}C = -28.408\text{‰}$ and $\Delta^{14}C = -768.97\text{‰}$ on NOSAMS' VG Optima isotope ratio mass spectrometer (IRMS) and Continuous-Flow Accelerator Mass Spectrometer (CFAMS) (Roberts et al. 2010), respectively. These values were used to determine the minimum amount of seawater the REDICS system can analyze before the process blank contribution impacts the accuracy of the IRMS (0.05‰) and the accelerator mass spectrometers (AMS) (5‰) measurements for a typical seawater sample ($[DIC] = 2 \text{ mmol kg}^{-1}$) (Table 1). Results obtained on samples smaller than the sizes listed in the table will be valid after correction, but the precision of the measurement will be impacted by propagation of uncertainties of the blank with the measurement. A comparison of the isotopic values of REDICS' process blank with the WSL processing blank (Table 2) shows that the processing blanks from both systems are small but contributed by different sources. This is, perhaps, not surprising given how different the systems and extraction methods are. The data was used for a mass-balance blank correction (Hayes 2002) of all REDICS data obtained during the validation process.

Precision and accuracy

Precision and accuracy were established by processing multiple seawater standards collected in the Atlantic Ocean in 2010 at 4000 m depth (7.9928° N , 51.5010° W) and comparing the stable and radiocarbon data to results acquired on the WSL. The stable isotope analysis was performed on a VG Prism or VG Optima IRMS and the radiocarbon analyses were obtained on NOSAMS' AMS (Von Reden et al. 2004) or CFAMS. A total of 64 standards were processed on REDICS, yielding 54 stable and 48 radiocarbon isotope results. The Atlantic Ocean seawater standards are routinely processed on the WSL for quality control; therefore the stable and radiocarbon isotope values are well established. Table 3 and Fig. 3 show a direct comparison of the blank-corrected REDICS and WSL results for standards processed since the beginning of 2013.

Table 3. Seawater standard comparison, REDICS vs. WSL.

System	Stable isotope results		Radiocarbon isotope results	
	N samples	$\delta^{13}C_{\text{‰}}$	N samples	$\Delta^{14}C_{\text{‰}}$
REDICS	54	1.076 ± 0.040	48	-84.9 ± 7.8
WSL	30	1.011 ± 0.066	31	-85.4 ± 6.1

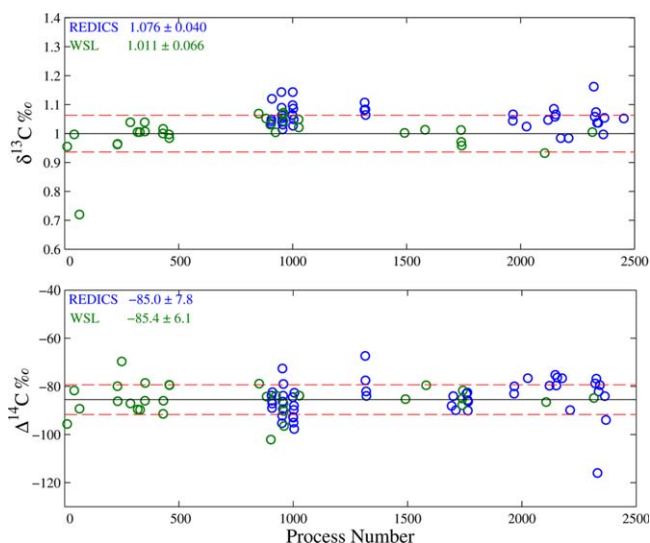
**Fig. 3.** Comparison of stable and radiocarbon isotope results from seawater standards processed on the REDICS and WSL systems since the beginning of 2013.

A comparison between the two datasets indicates that the REDICS system's accuracy is high for radiocarbon analysis; however it is slightly lower for stable isotope analysis with a difference of 0.065‰ . It is not clear what causes the slight stable isotope offset. The precision of both systems is high and comparable.

Membrane contactor memory effect

A series of tests with radiocarbon-dead groundwater standards and the seawater standard were also performed to investigate whether the membrane contactor has any measurable memory effects (Fig. 4). The results verified that no memory effects were detectable.

Ocean profile

The REDICS system was further validated by processing samples from a depth profile collected in the Sargasso Sea. Samples were collected in May 2012 at Station QL-2 (39.0002° N , 69.0001° W) on the KN207-01 cruise headed to Bermuda, on board RV Knorr. Duplicate samples were collected at each depth. One bottle was analyzed in duplicate or triplicate on REDICS and one bottle was analyzed on the WSL. The stable and radiocarbon results from both systems were then compared (Fig. 5).

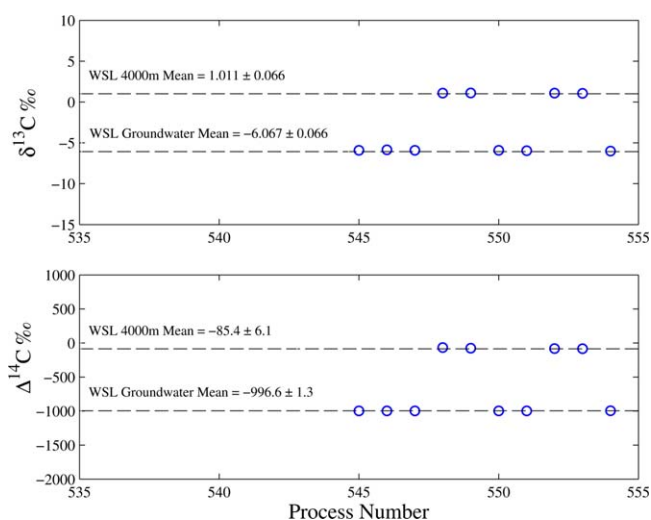

Fig. 4. Membrane contactor memory effect test: a series of radiocarbon dead groundwater standards and seawater standards.

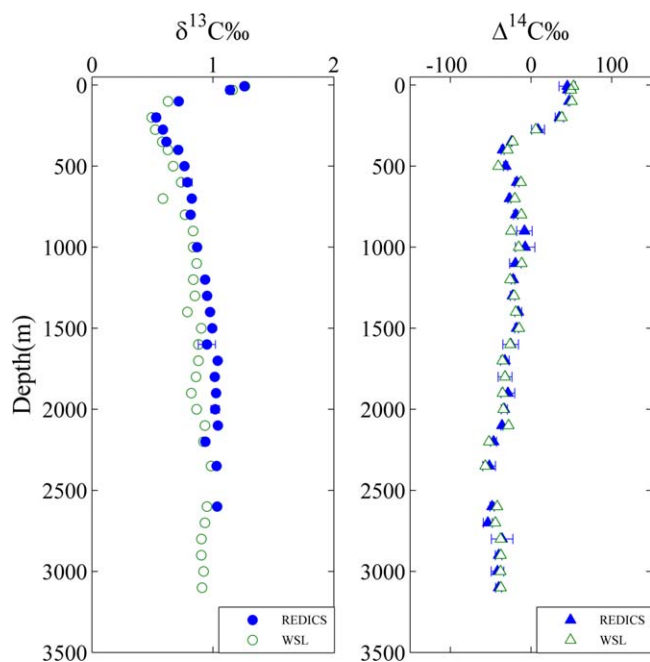

Fig. 5. Sargasso Sea depth profile: stable and radiocarbon isotope data processed on both the REDICS system and the WSL.

The REDICS data are highly precise for both stable and radiocarbon analysis with pooled standard deviations of 0.023‰ and 5.60‰ respectively. A comparison between the REDICS and WSL datasets indicates a high accuracy for radiocarbon work and lower accuracy for stable isotope analysis. It is apparent in Fig. 5 that there is better agreement in the stable isotope data from the two methods between 0 m and 1000 m depth than there is between 1000 m and 2000 m depth. A cryogenic trap was used to remove water

from the gas stream during the trapping phase for the samples between 0 m and 1000 m while the Nafion dryer was used for the samples between 1000 m and 2000 m. Excluding the stable isotope data collected with the Nafion dryer, we observe an offset in the $DI^{13}C$ values that is similar to the 0.065‰ observed with the standards. We suspect there may be some fractionation through the Nafion dryer and will be investigating this further in the future.

Conclusions

The REDICS system successfully extracts, quantifies, and stores more than 99% of seawater and groundwater DIC in less than 20 min. The system offers multiple advantages to NOSAMS' WSL, including short set-up time, fast and streamlined sample processing, as well as commercially available hardware.

The system was tested extensively against the WSL using Atlantic Ocean seawater standards and depth profile seawater samples from the Sargasso Sea. Stable isotope and radiocarbon isotope data demonstrate great system precision. REDICS' radiocarbon results show great accuracy as well, appropriate for a wide range of studies. The stable isotope accuracy can be further improved on by minor redesign of several system components.

References

- Bandstra, L., B. Hales, and T. Takahashi. 2006. High-frequency measurements of total CO_2 : Method development and first oceanographic observations. *Mar. Chem.* **100**: 24–38. doi:10.1016/j.marchem.2005.10.009
- Doney, S., and others. 2009. Surface-ocean CO_2 variability and vulnerability. *Deep-Sea Res. Part 2 Top. Stud. Oceanogr.* **56**: 504–511. doi:10.1016/j.dsr2.2008.12.016
- Elder, K., A. McNichol, and A. Gagnon. 1998. Reproducibility of seawater, inorganic and organic carbon $14C$ results at NOSAMS. *Radiocarbon* **40**: 223–230.
- Gao, P., and others. 2014. Rapid sample preparation of dissolved inorganic carbon in natural waters using a headspace-extraction approach for radiocarbon analysis by accelerator mass spectrometry. *Limnol. Oceanogr.: Methods* **12**: 174–190. doi:10.4319/lom.2014.12.172
- Graven, H. D., N. Gruber, R. Key, S. Khatiwala, and X. Giraud. 2012. Changing controls on oceanic radiocarbon: New insights on shallow-to-deep ocean exchange and anthropogenic CO_2 uptake. *J. Geophys. Res.* **117**: C10005. doi:10.1029/2012JC008074
- Hales, B., D. Chipman, and T. Takahashi. 2004. High-frequency measurement of partial pressure and total concentration of carbon dioxide in seawater using microporous hydrophobic membrane contactors. *Limnol. Oceanogr.: Methods* **2**: 356–364. doi:10.4319/lom.2004.2.356

- Hayes, J. 2002. Practice and principles of isotopic measurements in organic geochemistry. Available from <http://www.whoi.edu/filesserver.do?id=73290&pt=2&p=74886>
- Joyce, T. M. 1988. The WOCE hydrographic program. *EOS Trans. AGU* **69**: 68–70. doi:[10.1029/88EO00050](https://doi.org/10.1029/88EO00050)
- Key, R. M., and others. 2004. A global ocean carbon climatology: Results from Global Data Analysis Project (GLODAP). *Global Biogeochem. Cycles* **18**: GB4031. doi:[10.1029/2004GB002247](https://doi.org/10.1029/2004GB002247)
- Ko, Y. H., K. Lee, P. D. Quay, and R. A. Feely. 2014. Decadal (1994–2008) change in the carbon isotope ratio in the eastern South Pacific Ocean. *Global Biogeochem. Cycles* **28**: 775–785. doi:[10.1002/2013GB004786](https://doi.org/10.1002/2013GB004786)
- Kortzinger, A., P. D. Quay, and R. E. Sonnerup. 2003. Relationship between anthropogenic CO_2 and the C-13 suess effect in the North Atlantic Ocean. *Global Biogeochem. Cycles* **17**: 1005. doi:[10.1029/2001GN001427](https://doi.org/10.1029/2001GN001427)
- Kumamoto, Y., A. Murata, T. Kawano, S. Watanabe, and M. Fukasawa. 2013. Decadal changes in bomb-produced radiocarbon in the Pacific Ocean from the 1990s to 2000s. *Radiocarbon* **55**: 1641–1650. doi:[10.2458/azu_js_rc.55.16238](https://doi.org/10.2458/azu_js_rc.55.16238)
- McNichol, A. P., G. A. Jones, D. L. Hutton, and A. R. Gagnon. 1994. The rapid preparation of seawater ΣCO_2 for radiocarbon analysis at the National Ocean Sciences AMS Facility. *Radiocarbon* **36**: 237–246.
- McNichol, A., and others. 2000. Ten years after—the WOCE AMS radiocarbon program. *Nucl. Instrum. Methods Phys. Res. B* **172**: 479–484. doi:[10.1016/S0168-583X\(00\)00093-8](https://doi.org/10.1016/S0168-583X(00)00093-8)
- Molnár, M., I. Hajdas, R. Janovics, L. Rinyu, H. Synal, M. Veres, and L. Wacker. 2013. C-14 analysis of groundwater down to the millilitre level. *Nucl. Instrum. Methods Phys. Res. B* **294**: 573–576. doi:[10.1016/j.nimb.2012.03.038](https://doi.org/10.1016/j.nimb.2012.03.038)
- Peng, T.-H., R. M. Key, and H. Östlund. 1997. Temporal variations of bomb radiocarbon inventory in the Pacific Ocean. *Mar. Chem.* **60**: 3–13. doi:[10.1016/S0304-4203\(97\)00089-3](https://doi.org/10.1016/S0304-4203(97)00089-3)
- Quay, P., R. Sonnerup, J. Stutsman, J. Maurer, A. Kortzinger, X. A. Padin, and C. Robinson. 2007. Anthropogenic CO_2 accumulation rates in the North Atlantic Ocean from changes in the C-13/C-12 of dissolved inorganic carbon. *Global Biogeochem. Cycles* **21**: GB1009. doi:[10.1029/2006GB002761](https://doi.org/10.1029/2006GB002761)
- Roberts, M., and others. 2010. A high-performance ^{14}C accelerator mass spectrometry system. *Radiocarbon* **52**: 228–235.
- Sabine, C., and others. 2004. The oceanic sink for anthropogenic CO_2 . *Science* **305**: 367–371. doi:[10.1126/science.1097403](https://doi.org/10.1126/science.1097403)
- Santos, I., D. Maher, and B. Eyre. 2012. Coupling automated radon and carbon dioxide measurements in coastal waters. *Environ. Sci. Technol.* **46**: 7685–7691. doi:[10.1021/es301961b](https://doi.org/10.1021/es301961b)
- Shah Walter, S. R., A. Gagnon, M. Roberts, A. P. McNichol, M. Lardie Gaylord, and E. Klein. 2015. Ultra-small graphitization reactors for ultra-microscale ^{14}C analysis at the National Ocean Sciences Accelerator Mass Spectrometry (NOSAMS) Facility. *Radiocarbon* **57**: 109–122. doi:[10.2458/azu_rc.57.18118](https://doi.org/10.2458/azu_rc.57.18118)
- Sridha, S., B. Smitha, and T. Aminabhavi. 2007. Separation of carbon dioxide from natural gas mixtures through polymeric membranes—a review. *Sep. Purif. Rev.* **36**: 113–174. doi:[10.1080/15422110601165967](https://doi.org/10.1080/15422110601165967)
- Von Reden, K., and others. 2004. Plans for expanded ^{14}C analyses at the NOSAMS facility—a status and progress report. *Nucl. Instrum. Methods Phys. Res. B* **223–224**: 50–54. doi:[10.1016/j.nimb.2004.04.014](https://doi.org/10.1016/j.nimb.2004.04.014)

Acknowledgments

This work wouldn't have been possible without the NOSAMS' staff members who carried out all stable and radiocarbon analyses. We are grateful for the assistance of the crew of the R/V *Knorr* and Ben Van Mooy who made the collection of the Sargasso Sea samples possible as part of the KN207-01 cruise. We would also like to thank Steve Beaupre and Cameron McIntyre for their invaluable input. NSF Cooperative Agreements for the Operation of a National Ocean Sciences Accelerator Mass Spectrometry Facility (OCE-0753487 and OCE-123966) supported this research.

Submitted 17 March 2015

Revised 7 August 2015

Accepted 25 August 2015

Associate editor: Mike DeGrandpre