



Arabian Sea Mixed Layer Dynamics Experiment

Mooring Deployment Cruise Report

R/V *Thomas Thompson* Cruise Number 40

11 October - 25 October 1994

by

Richard P. Trask
Bryan S. Way
William M. Ostrom
Geoffrey P. Allsup
Robert A. Weller

DOCUMENT
LIBRARY
Woods Hole Oceanographic
Institution

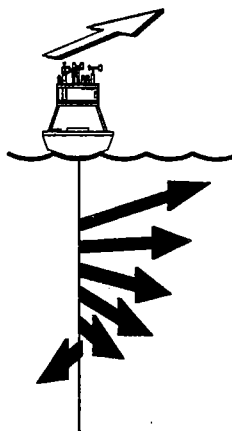

Upper Ocean Processes Group
Woods Hole Oceanographic Institution
Woods Hole, Massachusetts 02543
UOP Technical Report 95-1

WHOI-95-01

Arabian Sea Mixed Layer Dynamics Experiment
Mooring Deployment Cruise Report

R/V *Thomas Thompson* Cruise Number 40
11 October-25 October 1994

by

Richard P. Trask, Bryan S. Way, William M. Ostrom,
Geoffrey P. Allsup, & Robert A. Weller

Woods Hole Oceanographic Institution
Woods Hole, Massachusetts 02543

January 1995

Technical Report

Funding was provided by the Office of Naval Research under Grant No. N00014-94-1-0161.

Reproduction in whole or in part is permitted for any purpose of the United States Government. This report should be cited as Woods Hole Oceanog. Inst. Tech. Rept., WHOI-95-01.

Approved for public release; distribution unlimited.

Approved for Distribution:



Philip L. Richardson, Chair
Department of Physical Oceanography



Abstract

An array of surface and subsurface moorings were deployed in the Arabian Sea to provide high quality time series of local forcing and upper ocean currents, temperature, and conductivity in order to investigate the dynamics of the ocean's response to the monsoonal forcing characteristic of the area. The moored array was deployed during R/V *Thomas Thompson* cruise number 40.

One Woods Hole Oceanographic Institution (WHOI) surface mooring, two Scripps Institution of Oceanography (SIO) surface moorings and two University of Washington (UW) Profiling Current Meter moorings were deployed. The moorings were deployed for a period of one year beginning in October 1994 as part of the Office of Naval Research (ONR) funded Arabian Sea experiment. Two six month deployments were planned. The moorings were deployed at 15.5°N 61.5°E (WHOI), 15.7°N 61.3°E (SIO), 15.3°N 61.3°E (SIO), 15.7°N 61.7°E (UW), and 15.3°N 61.7°E (UW).

The WHOI surface mooring was outfitted with two meteorological data collection systems. A Vector Averaging Wind Recorder (VAWR) and an IMET system made measurements of wind speed and direction, sea surface temperature, air temperature, short wave radiation, long wave radiation, barometric pressure, relative humidity and precipitation. Subsurface instrumentation included Vector Measuring Current Meters (VMCMs), Multi-Variable Moored Systems (MVMS), conductivity and temperature recorders and single point temperature recorders.

Expendable bathythermograph (XBT) data and CTD data were collected while in transit to the site and between mooring locations.

This report describes in a general manner the work that took place during R/V *Thomas Thompson* cruise number 40 which was the initial deployment cruise for this moored array. A detailed description of the WHOI surface mooring and its instrumentation is provided. Information about the XBT and CTD data collected during the cruise is also included.

Table of Contents

	Page
List of Figures	3
List of Tables	4
Section I: Introduction	5
Section II: The Moored Array	8
A. WHOI Surface Mooring	8
B. WHOI Instrumentation	12
1. Meteorological Instrumentation	12
a. Vector Averaging Wind Recorder	12
b. IMET Meteorological System	16
c. Stand Alone Relative Humidity with Temperature Sensor	18
2. Sub-Surface Instrumentation	18
a. Buoy Tension Recorder	18
b. Sub-surface Argos Transmitter	18
c. Seacat Conductivity and Temperature Recorder	20
d. Dissolved Oxygen Sensor	20
e. Brancker Temperature Recorder	20
f. Miniature Temperature Recorder (MTR)	22
g. WHOI Vector Measuring Current Meter	22
h. USC Multi-Variable Moored System	22
i. LDEO Multi-Variable Moored System	23
j. Tracor Applied Sciences Bio-Acoustic Instrument	23
k. Acoustic Release	23
Section III: Cruise Chronology	24
References	34
Acknowledgements	34
Appendix 1: Cruise Participants	35
Appendix 2: XBT Positions	36
Appendix 3: CTD Positions	40
Appendix 4: Instrument Summary	42
Appendix 5: Wind Direction Comparison Tests	44
Appendix 6: WHOI VMCM Record Format	47
Appendix 7: Mooring Deployment Procedures and Related Notes	48
Appendix 8: Deployment Information About WHOI Instrumentation on PCM Moorings	62

List of Figures

	Page
Figure 1: Arabian Sea mooring cruise schedule	6
Figure 2: Cruise track and mooring locations	7
Figure 3: Arabian Sea moored array instrument locations	9
Figure 4: WHOI surface mooring schematic	10
Figure 5: Near-surface temperature array on the WHOI discus buoy	21
Figure 6: WHOI surface mooring acoustic release survey	26
Figure 7: Profile of CTD data collected near the WHOI surface mooring	27
Figure 8: SIO surface mooring schematic	28
Figure A5-1: VAWR wind direction comparison test conducted at WHOI	45
Figure A5-2: VAWR and IMET wind direction comparison test conducted in Muscat, Oman.	46
Figure A7-1: Deck plan of the R/V <i>T.Thompson</i> during cruise number 40.	49
Figure A7-2: Personnel work stations during surface buoy deployments	50
Figure A7-3: WHOI surface mooring schematic	51
Figure A7-4: UOP Discus buoy bail configuration	54
Figure A7-5: PCM mooring schematic	56
Figure A7-6: Buoy hull antifouling paint test locations	61

List of Tables

	Page
Table 1. Arabian Sea Mooring Deployment Information	6
Table 2. Arabian Sea Moored Array Instrumentation	13
Table 3. VAWR Sensor Specifications	14
Table 4. Sensors mounted on the WHOI surface buoy and their heights (depths) relative to the buoy deck	19
Table A7-1. Winch payout meter readings for different ship speeds	60

Section I: Introduction

Cruise number 40 of the R/V *Thomas Thompson* (TN040) departed Muscat, Oman, on 11 October 1994 at 0300 UTC. The purpose of the cruise was to deploy one Woods Hole Oceanographic Institution (WHOI) surface mooring, two Scripps Institution of Oceanography (SIO) surface moorings and two University of Washington (UW) subsurface Profiling Current Meter (PCM) moorings. All five moorings were part of the Office of Naval Research (ONR) funded Arabian Sea experiment. This was the first of three cruises associated with servicing the array of moorings. A turnaround cruise is planned for April 1995 at which time the surface moorings will be recovered and redeployed. The final recovery of all moorings is planned for October 1995. The mooring deployment schedule is shown in Figure 1.

The cruise involved personnel from the Woods Hole Oceanographic Institution (WHOI), Scripps Institution of Oceanography (SIO), University of Southern California (USC), Lamont Doherty Earth Observatory (LDEO), University of Washington (UW), University of South Florida and Texas A and M University. Appendix 1 lists the cruise participants. Figure 2 shows the cruise track and the mooring locations. Table 1 lists the positions of the moorings deployed during this cruise.

While enroute to the mooring array site hourly XBT data were collected. During the bathymetric survey that preceded the mooring deployments XBT data were collected every 15 minutes. The XBT positions appear in Appendix 2. A total of 61 CTD casts were made throughout the cruise. The last thirty five casts were done in a tow yo fashion between the surface and 300 meters depth as the ship transitted northward from the southern part of the moored array. Appendix 3 contains the CTD positions, start times and maximum depth of the stations.

This report has in addition to this introduction three sections. The second section primarily describes the WHOI mooring and the instrumentation that was deployed on the WHOI mooring. The third section is a chronology of the entire cruise.

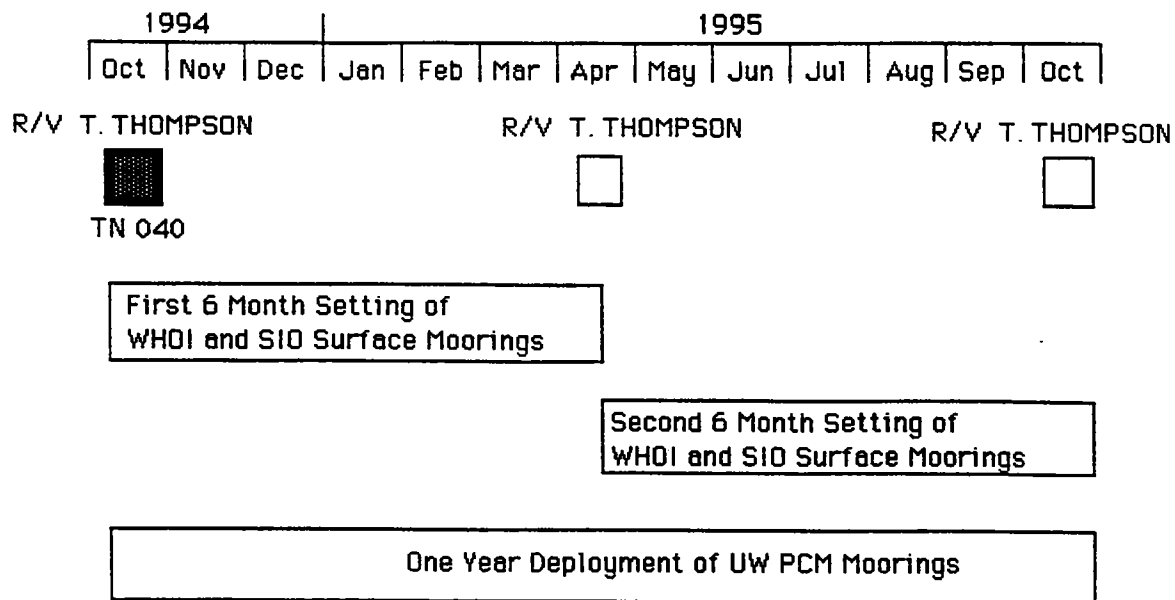

Figure 1. Arabian Sea mooring cruise schedule.

Table 1. Arabian Sea Mooring Deployment Information

Mooring	WHOI Reference #	Deployment Date and Time	Anchor Position
WHOI Discus Buoy	969	15 October 1994 @1048 UTC	15°30.04'N 61°29.99'E
SIO Northern Buoy		17 October 1994 @0723 UTC	15°43.53'N 61°15.94'E
SIO Southern Buoy		18 October 1994 @0649 UTC	15°16.53'N 61°16.11'E
UW Northern PCM	972*	20 October 1994 23 October 1994	15°43.90'N 61°44.53'E
UW Southern PCM	970	19 October 1994	15°16.37'N 61°44.07'E

The first deployment (WHOI reference #271) of the Northern PCM mooring was on 20 October 94 at position 15°43.75'N, 61°43.95'E. It was recovered on 22 October 94 at approximately 1100 UTC in order to correct for a depth recorder error. The redeployment is as shown above.*

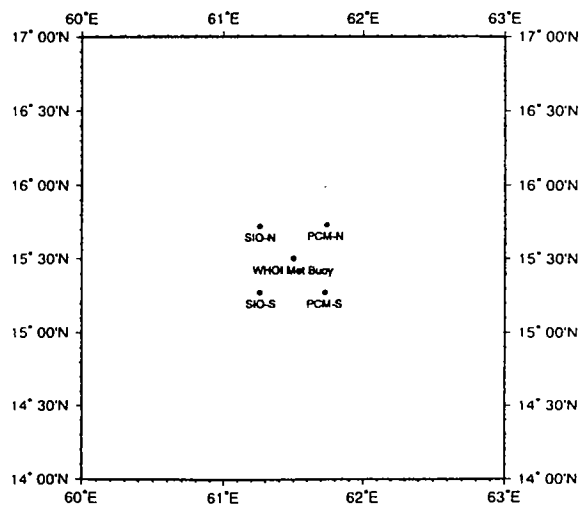
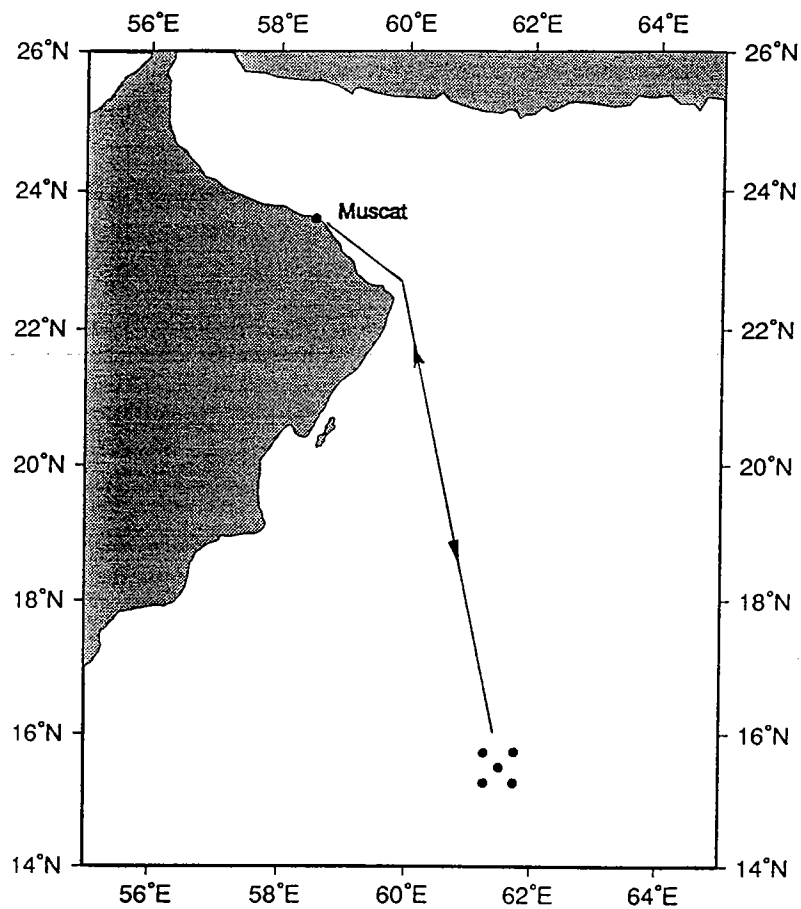

Figure 2: Cruise track and mooring locations.

Section II: The Moored Array

Five moorings were deployed during cruise number 40 of the R/V *Thomas Thompson*. The central mooring in the array was a WHOI / Upper Ocean Processes (UOP) group surface mooring with meteorological and oceanographic instrumentation. The WHOI mooring will be described in greater detail in the following sections. To the west of the WHOI mooring were two SIO surface moorings utilizing 7'-6" diameter toroid shaped buoys for their primary flotation. The buoys were outfitted with a tower that contained two redundant meteorological systems measuring wind speed and direction, air temperature, sea surface temperature, short wave radiation, and barometric pressure. The subsurface instrumentation on each SIO mooring included a downward looking ADCP mounted in the buoy bridle and 10 temperature recorders mounted on the wire in the upper 150 meters. The SIO moorings were given a north and south designation. To the east of the WHOI surface mooring there were two University of Washington subsurface profiling current meter moorings. These were also given a north and south designation. The PCM was designed to cycle between 26 and 202.5 meters. Both PCM moorings had a WHOI temperature logger mounted on the top sphere of the mooring at approximately 20 meters and another at approximately 250 meters depth. The southern PCM mooring also had five WHOI VMCMs at approximately 300, 500, 750, 1500, and 3000 meters depth. Figure 3 schematically shows all five moorings and the location of the subsurface instrumentation.

A. WHOI Surface Mooring

The WHOI mooring deployed in the Arabian Sea is shown schematically in Figure 4. The surface buoy is a three meter diameter discus shaped buoy with a two part aluminum tower and rigid bridle. Eighteen meteorological sensors are mounted on the top half of the buoy tower and are described in the following section. Eleven near-surface oceanographic sensors are attached to the bridle and buoy hull.

The mooring is an inverse catenary design utilizing chain, wire rope, nylon and polypropylene and has a scope (Scope = slack length/water depth) of 1.22. In addition to the buoy mounted instruments the mooring supports an additional 27 recording packages, some of which have multiple sensors.

The design of the Arabian Sea mooring took into consideration the high wind and sea state conditions expected during the monsoons. It is believed that the static and dynamic loads that the Arabian Sea surface mooring will experience are of such magnitude and duration that conventional designs used successfully in the past in more benign environments may not last in the Arabian Sea. This is because the dynamic loading may be so severe that ultimate strength considerations are superseded by the fatigue properties of the standard hardware components.

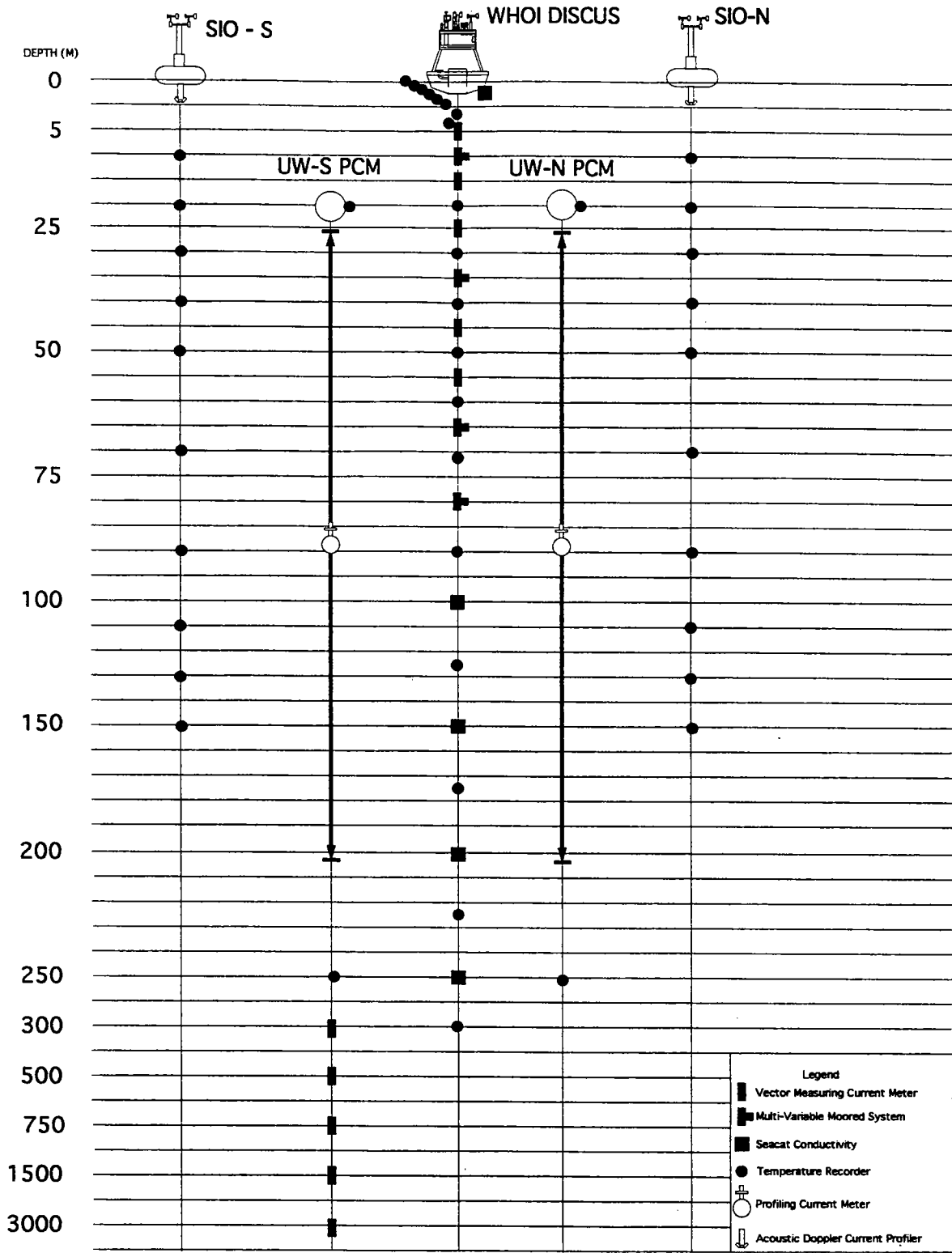

Figure 3: Arabian Sea moored array instrument locations.

MAXIMUM DIAMETER OF BUOY
WATCH CIRCLE = 3.5 N. MILES

3 meter Discus Buoy with VAWR (With
Argos Telemetry), IMET, and Tension
Argos Transmitter

TEMPERATURE PODS	
NO.	DEPTH(M)
1	0.25M Buoy Pipe
2	0.5M Buoy Pipe
3	1 M-Bridle Pipe
4	1.5 M-Bridle Pipe
5	2 M-Bridle Pipe
6	2.5 M-Bridle Pipe
7	3.5 M (MTR)
8	4.5 M-VMCM Cage
9	20
10	30
11	40 M Cage
12	50
13	60
14	72.5
15	90
16	125
17	175
18	225
19	300

TERMINATION CODES	
(A)	BRIDLE: U-JOINT, 1" CHAIN SHACKLE 1" ENDLINK, 7/8" CHAIN SHACKLE
(B)	7/8" CHAIN SHACKLE, 7/8" ENDLINK, 7/8" CHAIN SHACKLE
(C)	3/4" CHAIN SHACKLE, 7/8" ENDLINK, 3/4" CHAIN SHACKLE
(D)	7/8" ANCHOR SHACKLE
(E)	3/4" ANCHOR SHACKLE, 7/8" ENDLINK, 3/4" ANCHOR SHACKLE
(F)	1" ANCHOR SHACKLE, 7/8" ENDLINK, 5/8" CHAIN SHACKLE
(G)	5/8" CHAIN SHACKLE, 7/8" ENDLINK, 5/8" CHAIN SHACKLE
(H)	5/8" CHAIN SHACKLE, 7/8" ENDLINK, 7/8" ANCHOR SHACKLE
(I)	7/8" CHAIN SHACKLE, 7/8" ENDLINK, 3/4" CHAIN SHACKLE

HARDWARE REQUIRED (INCLUDES APPROX. 20% SPARES)	
1" CHAIN SHACKLES	5
1" ANCHOR SHACKLES	5
1" WELDLESS ENDLINKS	5
7/8" ANCHOR SHACKLES	5
7/8" CHAIN SHACKLES	10
7/8" WELDLESS ENDLINKS	85
3/4" CHAIN SHACKLES	85
3/4" ANCHOR SHACKLES	10
5/8" CHAIN SHACKLES	65

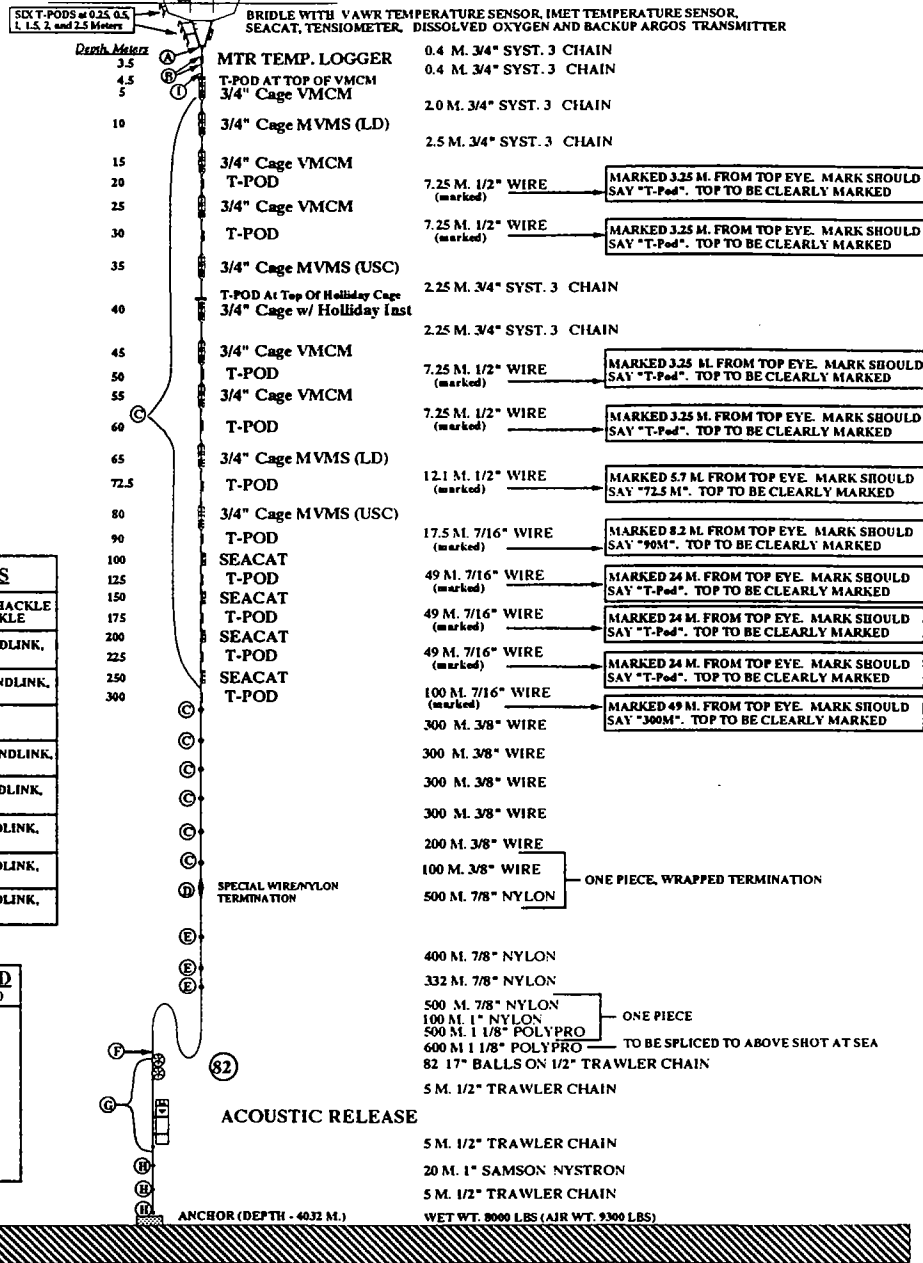

ARABIAN SEA MOORING

NOMINAL POSITION - 15.5° N 61.5° E

G. TUPPER/R/TRASK
APRIL 4, 1994
REV 18 MAY 94
REV 15 JUN 94
REV 30 OCT 94

Figure 4: WHOI surface mooring schematic.

During the mooring design process cyclic fatigue tests were conducted on pear rings, shackles, wire rope, load cages, and chain to study the fatigue life of these various components. The fatigue tests showed that weldless sling links also known as pear rings have a relatively short fatigue life when cycled with tensions that a mooring in the Arabian Sea might experience. These components were replaced by 7/8" weldless end links which faired very well during the fatigue tests. In the same manner 3/4" shackles were found to have marginal fatigue characteristics when subjected to the expected tensions. By shot peening the 3/4" shackles their fatigue performance improved greatly.

Shot peening is a process whereby a component is blasted with small spherical media called shot in a manner similar to the process of sand blasting. It differs from sand blasting in that the media used in shot peening is more rounded rather than angular and sharp as in sand blasting. Each piece of shot acts like a small ball peen hammer and tends to dimple the surface that it strikes. At each dimple site the surface fiber of the material is placed in tension. Immediately below the surface of each dimple the material is highly stressed in compression so as to counteract the tensile stress at the surface. A shot peened part with its many overlapping dimples therefore has a surface layer with residual compressive stress. Cracks do not tend to initiate or propagate in a compressive stress zone. Since cracks usually start at the surface, a shot peened component will take longer to develop a crack thereby increasing the fatigue life of the part. Many materials will also increase in surface hardness due to the cold working effect of shot peening.

The compressive stresses introduced by shot peening increase the resistance to fatigue failures, corrosion fatigue, stress corrosion cracking, hydrogen assisted cracking, fretting, galling, and erosion caused by cavitation. The benefits of cold working include work hardening, and intergranular corrosion resistance.

Another in-line component that was reviewed during the design process was the load cages of the VMCM. Cage fabrication specifications were found to be so loosely defined that there was potential for considerable variability from cage to cage. With the help of Stonebridge Corporation the appropriate welding specifications were identified. In addition it was felt that dye penetrant inspection of all welds by a certified inspector would provide a level of quality control not present in our existing cages. For new fabrication, certification of the origin of the material was added.

Stonebridge also provided assistance in designing a gusset to be welded between the longitudinal members and the end bales to stiffen the cage and improve its fatigue life. Gussets were retrofitted to the existing WHOI VMCM cages by Stonebridge Corp. While the cages were being outfitted with gussets they also had their welds brought up to specification and dye penetrant inspected. New cages were fabricated for the MVMS and bio-acoustic instruments according to the new specifications.

B. WHOI Instrumentation

A total of 37 recording instruments with 95 sensors were deployed on the WHOI surface mooring. There were two meteorological systems, nine current meters (four with bio-optical sensors), 19 temperature data loggers, five conductivity recording instruments, one tension recorder and one bio-acoustic instrument. The specific instrumentation deployed during this cruise is shown in Table 2. Appendix 4 has a complete listing of all WHOI instrumentation that was deployed during TN 40. The listing shows for each instrument type the serial number, on which mooring it was deployed and at what depth.

1. Meteorological Instrumentation

The WHOI discus buoy was outfitted with two separate meteorological packages. One system was Vector Averaging Wind Recorder which logged and telemetered data from eight meteorological sensors. The second meteorological data recording system called IMET (for Improved METeorological measurements) logged data from nine meteorological sensors. A third instrument made an independent measurement of relative humidity and temperature and recorded the data internally. All three systems are described in detail below.

a. Vector Averaging Wind Recorder

One of the two meteorological units mounted on the 3 meter discus buoy is a Vector Averaging Wind Recorder (VAWR). The VAWR is configured to measure wind speed, wind direction, short wave radiation, long wave radiation, relative humidity, barometric pressure, air temperature, and sea surface temperature.

Recording on a digital cassette tape the VAWR is sampling at a 7.50 minute rate. Table 3 shows the type of sensors used for the meteorological measurements and the sampling scheme.

Data from the VAWR is being telemetered via satellite back to WHOI through Service Argos. The VAWR ARGOS transmitter has three PTT I.D. numbers for data transmission, one of which is used for obtaining position information.

The standard temperature range typically used in the VAWR is 0–30°C. This range was modified to be 0 to 35°C for the Arabian Sea experiment due to the expected high temperatures.

The VAWR sea surface temperature (SST) sensor was mounted on the bridle at a depth of one meter. A continuous length of was run from the VAWR to the buoy deck and then down to the bridle mounted SST sensor via an external aluminum pipe

**Table 2
Arabian Sea Experiment
Moored Array Instrumentation**

DEPTH (meters)	SIO-S	UW-S PCM	WHOI	UW-N PCM	SIO-N
0.25			T-3836		
0.5			T-3662		
1			T-4483		
1			SST V721WR		
1			IMET SST		
1.5	ADCP 167		T-5432		ADCP 195
1.5			T-3667		
1.5			SEACAT 1179		
1.5			Dissolved Oxygen		
2			T-3839		
2.5			T-3762		
3.5			MTR-3240		
4.5			T-3763		
5			VM-011		
10	SIO T-3270		LD MVMS 302703		SIO T-3294
15			VM-037		
20	SIO T-3715	T-3265	T-3259	T-3279	SIO T-3306
25			VM-039		
30	SIO T-3281		T-3305		SIO T-3276
35			USC MVMS 500501		
40	SIO T-3307		BIO-ACOUSTIC		SIO T-3708
40			T-3703		
45			VM-033		
50	SIO T-3713		T-4489		SIO T-3314
55			VM-015		
60			T-4487		
65			LD MVMS 401405		
70	SIO T-3706				SIO T-3282
72.5			T-4481		
80			USC MVMS 500601		
90	SIO T-3295		T-3301		SIO T-3714
100			SEACAT 357		
110	SIO T-3278				SIO T-3275
125			T-4491		
130	SIO T-3277				SIO T-3304
150	SIO T-3292		SEACAT 0994		SIO T-3310
175			T-3761		
200			SEACAT 992		
225			T-4493		
250		T-2537	SEACAT 993	T-2541	
300		VM-016	T-2534		
500		VM-018			
750		VM-021			
1500		VM-025			
3025		VM-038			

Legend:

T-####	WHOI Temperature Recorder
SIO T-####	SIO Temperature Recorder
Seacat ###	Seacat Conductivity and Temperature Recorder
ADCP ###	SIO Acoustic Doppler Current Profiler
Bio Acoustic	Tracor Science Applications Bio Acoustic Instrument
USC MVMS #####	University of Southern California Multi-Variable Moored System
LD MVMS #####	Lamont Doherty Earth Observatory Multi-Variable Moored System
MTR-####	WHOI Temperature Recorder

Table 3. VAWR Sensor Specifications

Parameter	Sensor Type	Accuracy	Record Time
Wind Speed	R.M. Young 3-cup Anemometer	+/- 2% above 0.7 m/s	Vector Averaged
Wind Direction	Integral Vane w/vane follower WHOI/EG&G	+/- 1 bit 5.6 degrees	Vector Averaged
Insolation	Pyranometer Eppley 8-48	+/- 3% of reading	Averaged
Long Wave Radiation Thermopile Body Temp. Dome Temp.	Pyrgeometer Eppley PIR PIR 10K @ 25 deg. C 10K @ 25 deg. C	+/- 10%	Averaged Note 4 Note 5
Relative Humidity	Variable Dielectric Conductor Vaisala Humicap 0062HM	+/- 2% RH	3.515 Sec. Sample Note 1
Barometric Pressure	Quartz crystal Digiquartz Paroscientific Model 215,216	+/- 0.2 mbars wind < 20 m/s	2.636 Sec. Sample Note 1
Sea Temperature	Thermistor Thermometrics 4K @ 25 degrees C	+/- 0.005 degrees C	Note 2
Air Temperature	Thermistor Yellow Springs #44034 5K @ 25 degrees C	+/- 0.2 degrees C wind > 5 m/s	Note 3

Notes:

1. Relative Humidity and Barometric Pressure are burst samples taken in the middle of the recording interval.
2. Sea temperature is measured during the first quarter of the recording interval, for one quarter of the record time.
3. Air temperature is measured during the second quarter of the recording interval, for one quarter of the record time.
4. LWR body temperature is measured during the third quarter of the recording interval, for one quarter of the record time.
5. LWR dome temperature is measured during the fourth quarter of the recording interval, for one quarter of the record time.

mounted on the side of the buoy to protect the cable. This method eliminates the need for multiple bulkhead connectors which can affect the temperature reading.

The VAWR deployed in the Arabian Sea experiment was modified to measure and record several long wave radiation parameters. The outputs from the thermopile, dome temperature and body temperature were recorded by the VAWR.

Wind tunnel tests have shown that the cage bars of the VAWR wind sensor have caused the vane to be offset, depending upon where the vane was in relation to the cage bars. If the vane was oriented such that it was in close proximity to one of the cage bars the turbulence around the bar tended to offset the vane from its true direction.

The findings of these tests and recent experience with one instrument from another experiment that was missing a vane upon recovery brought about some changes to the VAWR vane for the Arabian Sea experiment. The length of the vane was shortened to 6.5". The general shape of the vane however, was not changed. The pivot rod was slotted so that the edge of the vane could be inserted. Nylon pins were inserted through the pivot rod and the vane to secure the vane to the bar. Two part epoxy was used as a filler to smooth the transition between the pivot bar and the vane as well as to provide extra strength to the joint.

The vane cage bars for the Arabian Sea experiment VAWR were inclined such that when viewed from above it appears as if the top had been rotated clockwise relative to the bottom plate. The VAWR was mounted on the buoy such that the VAWR lubber line is not perpendicular to the front face of the buoy. It was rotated approximately 15° in a clockwise direction so as to offset the location of the rear cage bar.

Prior to shipment to Oman the air and sea temperature sensors as well as the relative humidity sensors were calibrated at WHOI. The calibrations of the barometric pressure sensors were checked at WHOI and if found out of specification were returned to the manufacturer for recalibration. The short wave and long wave radiation sensors were calibrated by the manufacturer. The wind direction sensor readings were compared with a known bearing to a fixed target both at WHOI and in Muscat. After reviewing the initial direction comparison data collected in Muscat the VAWR vane doughnut that holds the magnets was rotated approximately 5 degrees clockwise. The buoy was then rechecked and the data compared favorably with the known heading and the IMET system. Details of the direction comparison tests can be found in Appendix 5. In addition the meteorological instruments were run on the buoy for two months prior to shipment to burn in all systems and work out the bugs. The data was compared with standards at WHOI.

b. IMET Meteorological System

The IMET meteorological sensor system for the Arabian Sea WHOI surface buoy consists of nine IMET sensor modules. The modules measure the following parameters:

1. Relative humidity with temperature;
2. Barometric pressure;
3. Air temperature (RM Young passive shield);
4. Air temperature (aspirated shield);
5. Sea surface temperature;
6. Precipitation;
7. Wind speed and direction;
8. Short wave radiation;
9. Long wave radiation.

All IMET modules for the Arabian Sea were modified for low power consumption so that a non-rechargeable alkaline power pack could be used.

The data logger for the system is based on an Onset Computer Corp. Model 7 Tattletale computer with hard drive, also configured and programmed with power conservation in mind. An associated interface board ties the Model 7 via individual power and RS-485 communications lines to each of the 9 IMET modules.

The following IMET modules and their associated software were deployed on the WHOI discus buoy.

Module	Software version used
HRH #111	IMETHRH v2.2
WND #104	IMETWND v2.0
LWR #101	IMETLWR v2.0
SST #106	IMETTMP v2.0
TMP #101	IMETTMP v2.0
SWR #109	IMETSWR v2.1
BPR #107	IMETBPR v2.0
PRC #101	IMETPRC v2.1
TMP #108 (ASPIRATED)	IMETTMP v2.0
LOGGER #226	LOGGER10 v1.5

Several problems were encountered while preparing the IMET instrumentation in Muscat, Oman. During the first attempt to verify correct wind direction output by rotating the buoy, an apparent problem was identified with the vane readings. They would either lock up or would not swing through all 360 degrees. Both the primary

and spare wind modules exhibited the same problem in test mode. The problem was fixed by revising the IMETWND firmware to re-initialize the 8255 parallel port on each cycle of the test mode (this periodic re-initialization was already present during normal operations). The wind direction readings were compared with a known bearing to a fixed target in Muscat. Details of the direction comparison tests can be found in Appendix 5.

The relative humidity module shield support plate was found cracked. The entire shield assembly was replaced with the shield assembly from the spare humidity module.

After connecting the sea surface temperature (SST) module to the system the SST data showed several gaps. The SEACON cable from the SST module to the bottom access plate bulkhead connector was intermittent at the female end. Since a spare was not available a new female pigtail was spliced to the original cable.

IMET Sampling Scheme

The logger polls all modules at one minute intervals (takes several seconds) and then goes to low power sleep mode for the rest of the minute. Data is written to disk once per hour.

The air temperature, sea surface temperature, barometric pressure, relative humidity, longwave radiation and precipitation modules take a sample once per minute and then go to low power sleep mode for the rest of the minute.

The short wave radiation module takes a sample every 10 seconds and produces a running one minute average of the six most recent samples. It goes to low power sleep mode between 10 second samples.

The vane on the wind module is sampled at one second intervals and averaged over 15 seconds. The compass is sampled every 15 seconds and the wind speed is averaged every 15 seconds. East and north current components are computed every 15 seconds.

Once a minute the logger stores an average east and north component that is an average of the most recent four 15 second averages. In addition average speed from four 15 second averages is stored, along with the maximum and minimum speed during the previous minute, average vane computed from four 15 second averages, and the most recent compass reading.

c. Stand Alone Relative Humidity / Temperature Instrument

A self contained relative humidity and temperature instrument was mounted on the tower of the WHOI discus buoy. This instrument, developed and built by members of the Upper Oceans Processes Group, takes a single point measurement of both relative humidity and temperature at a desired record interval. The sensor used is a Rotronics MP-100. The relative humidity and temperature measurements are made inside a protective Gortex shield. The logger is an Onset Computer Corp. model 4A Tattletale with expanded memory to 512K. The unit is powered by its own internal battery pack.

The mechanical housing is PVC pipe which has been machined to accept end caps with an oring seal. A multi-plate radiation shield protects the sensors from direct sunlight and is similar to that used on the VAWR relative humidity sensor. The recording interval was set to 3.75 minutes for the Arabian Sea experiment.

The height (and depth) of the buoy and bridle mounted instrumentation (relative to the buoy deck) can be found in Table 4. The predicted water line on the buoy is approximately 0.3 meters below the buoy deck but will be accurately measured when the buoy is recovered.

2. Subsurface Instrumentation

a. Buoy Tension Recorder

Buoy tension was measured at the base of the buoy bridle using a DJ Instruments Co. tension cell and recorded using an Onset Computer Corp. Model 6 Tattletale. The tension cell was rated from 0 to 10,000 pounds. The sampling rate for tension in a 12 hour period beginning at 0000 and 1200 UTC is as follows:

45 minutes of 4 Hz tension.

15 minutes of 20 second max/min/average of 4 Hz tension.

11 hours of 20 second max/min/average of 4 Hz tension.

This is repeated every 12 hours for a 48 hour cycle. The data is then stored to a hard disk on the Tattletale.

An Argos transmitter is connected to the tension logger so that a single point tension measurement is included with every transmission. Position information is obtained from Service Argos based on these tension transmissions.

b. Sub-Surface Argos Transmitter

An NACLS Inc. Subsurface Mooring Monitor (SMM) is mounted upside down on the bridle of the discus buoy as a backup recovery aid in the event that the mooring parts and the buoy flips upside down. The SMM has an internal mercury switch which

Table 4. Sensors mounted on the WHOI surface buoy and their elevation relative to the buoy deck.

Parameter	Sensor ID	Elevation relative to buoy deck (meters)	Measurement Location
VAWR			
	V721WR		
Air Temp	Therm. 5804	2.30	Mid shield
Relative Hum	V-034-001	2.31	Mid shield
Barom. Press	S/N 46398	2.38	Center of Port
Wind Speed	V721WR	2.98	Center of cups
Wind Direction	V721WR	2.69	Mid Vane
Short Wave	S/N 25418	3.04	Base of dome
Long Wave	S/N 28463	3.04	Base of dome
Sea Temp	Therm. 5005	-1.30	End of Probe
IMET			
	Logger No. 226		
Air Temp	TMP #101	2.36	Mid Shield
Relative Hum	HRH #111	2.36	Mid Shield
Barom. Press	BPR #107	2.39	Center of Port
Wind Speed	WND #104	2.78	Prop Axis
Wind Direction	WND #104	2.78	Prop Axis
Short Wave	SWR #109	3.04	Base of dome
Long Wave	LWR #101	3.04	Base of dome
Precipitation	PRC #101	2.76	Top of Funnel
Sea Temp	SST #106	-1.27	Tip of probe
Aspirated Air Temp	TMP #108	1.82	Opening of port
Stand alone RH w/ temp	#002	2.60	Mid Shield
Seacat	S/N 1179	-1.80	At Temp Probe
Dissolved Oxygen	No. 60	-1.80	Sensor end
T-POD	5432	-1.75	Thermistor end
T-POD	3836	-0.55	Thermistor end
T-POD	3662	-0.81	Thermistor end
T-POD	4483	-1.30	Thermistor end
T-POD	3667	-1.79	Thermistor end
T-POD	3839	-2.29	Thermistor end
T-POD	3762	-2.78	Thermistor end

(-) indicates distance below buoy deck

Nominal distance between buoy deck and water line is .3 meters

turns an Argos transmitter on when the unit is upright. If the mooring parted and the buoy became unstable and flipped upside down the Argos transmitter would switch on and the buoy position could be tracked.

c. SEACAT Conductivity and Temperature Recorders

There were five Seabird Seacats conductivity and temperature recorders deployed on the WHOI surface mooring. The shallowest Seacat was mounted directly to the bridle of the discus buoy. The other four were mounted on in-line tension bars and deployed at 100, 150, 200, and 250 meters depth.

The Seacat takes a single point measurement of salinity and temperature at the desired sample rate. On the UOP mooring the Seacats were set to sample every 7.50 minutes.

d. Dissolved Oxygen Sensor

A LDEO self powered internally recording dissolved oxygen instrument was mounted to the buoy bridle at 1.5 meters depth.

e. Brancker Temperature Recorders

A total of 18 Richard Brancker Research Ltd temperature data loggers (also known as "Branckers" or "T-Pods") were deployed at various depths from .25 meters to 300 meters on the WHOI surface mooring. Figure 4 (mooring schematic) lists the depths where T-Pods were located. The Brancker temperature loggers take a single point temperature measurement every record sample. The UOP Branckers were set for a record rate of 15 minutes.

Six Branckers were mounted on the buoy hull and bridle at depths ranging from .25 meters down to 2.5 meters. Figure 5 shows the discus buoy hull and the location of the six near surface T-pods. The near-surface temperature loggers are mounted in multi-plate solar radiation shields which are intended to minimize the direct solar heating of the instrument. The depths shown in Figure 5 are relative to the buoy deck. The instruments were positioned relative to a predicted waterline which was based on a prediction of the mooring tensions. The mean location of the waterline will be measured when the buoy is recovered. The actual depths of the sensors will then be computed. During a small boat visit to the buoy shortly after deployment the depth of the top Brancker was measured relative to the water surface and was very close to the desired .25 meters.

Two UOP Branckers were deployed on each of the University of Washington PCM moorings. Both moorings had one mounted on the top sphere at approximately 20 meters depth and the other was at 250 meters depth.

UOP Arabian Sea Discus Bridle Configuration

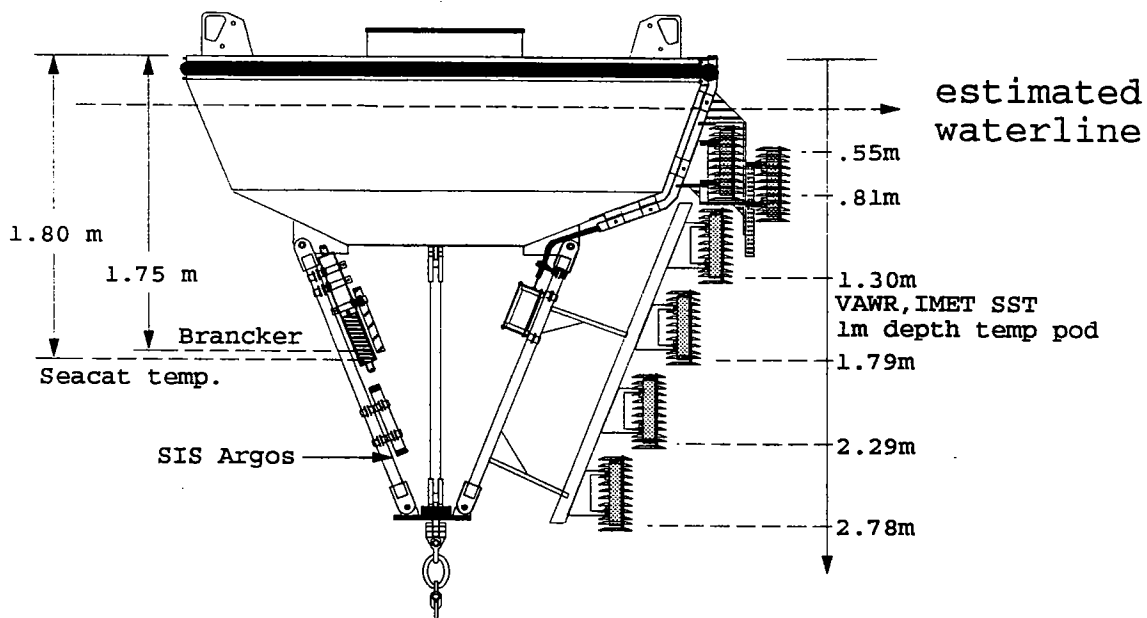

Note:
 measurements were made
 from buoy deck down.
 scale: 1" = 3'
 W.Ostrom
 11/4/94

Figure 5: Near-surface temperature array on the WHOI discus buoy.

f. Miniature Temperature Recorder (MTR)

A single Pacific Marine Environmental Lab, Miniature Temperature Recorder (MTR), was mounted at 3.5 meters depth in-line on the mooring. The MTR was mounted inside a 5-sided heavy duty steel box which was attached to an in line tension bar. Such a mounting arrangement was necessary to protect the MTR since its close proximity to the buoy bridle places it in a very vulnerable location during deployment and recovery. The MTR takes a single point temperature measurement every record sample which for the Arabian Sea deployment was set at 7.5 minutes.

g. WHOI Vector Measuring Current Meters

Five WHOI Vector Measuring Current Meters (VMCM) were deployed on the WHOI surface mooring at 5, 15, 25, 45, and 55 meters depth. The five surface mooring VMCMs record data on digital cassette every 3.75 minutes. A description of how each parameter is sampled is provided in Appendix 6.

The WHOI VMCMs incorporated several changes to the standard EG&G Sea Link product. These included different propeller bearings, a different plastic for the propeller blades and a redesign of the instrument cage including recent gusseting specifically for the Arabian Sea deployment. All VMCMs deployed on the WHOI surface mooring had cages with 3/4" cage rods and a single cross brace to support the sting between the two sets of propellers. See section 1A of this report for more details about the cage gusseting.

The VMCM's were outfitted with Silicone Nitride bearings, which have performed well in previous at-sea deployments. During the Subduction experiment VMCM propeller assemblies outfitted with similar bearings were deployed for a total of 24 months without any bearing failures. The propeller blades used in the Arabian Sea were made from injection molded Delrin® 100ST. Details about the VMCM bearings and propeller blade material can be found in Trask and Brink (1993).

Five WHOI VMCMs were also deployed on the University of Washington southern PCM mooring. Their nominal depths were 300, 500, 750, 1500, and 3000 meters. The record rate of the PCM mooring VMCMs was 7.5 minutes since a one year deployment was planned. Propeller shaft bearings and propeller materials were the same as those used on the WHOI surface mooring VMCMs. The VMCM cages used on the PCM mooring had 1/2" cage rods and a single cross brace to support the sting.

h. USC Multi-Variable Moored System

USC deployed two multivariable moored systems (MVMS) units on the WHOI surface mooring at 35 meters and 80 meters. Each MVMS records current vectors, rotor counts, compass, temperature, PAR, dissolved oxygen, dissolved oxygen

