

**Woods Hole
Oceanographic
Institution**

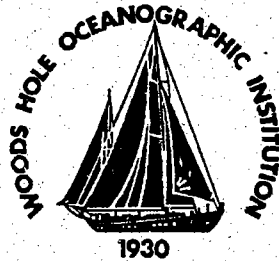

Status Report on MicroSat Data Telemetry

by

James R. Valdes

June 1992

Technical Report

Funding was provided by the Office of Naval Research
under Contract No. N00014-90-0013.

Approved for public release; distribution unlimited.

DOCUMENT
LIBRARY
Woods Hole Oceanographic
Institution

WHOI-92-25

Status Report on MicroSat Data Telemetry

by

James R. Valdes

Woods Hole Oceanographic Institution
Woods Hole, Massachusetts 02543

June 1992

Technical Report

Funding was provided by the Office of Naval Research
under Contract No. N00014-90-0013.

Reproduction in whole or in part is permitted for any purpose of the United States
Government. This report should be cited as Woods Hole Oceanog. Inst. Tech. Rept.,
WHOI-92-25.

Approved for public release; distribution unlimited.

Approved for Distribution:



James Luyten, Chairman
Department of Physical Oceanography



Table of Contents

	page
1.0 Abstract	3
2.0 Overview	4
2.1 Purpose of Project	4
2.2 Satellite Operating System	5
3.0 Unanticipated Problems	7
4.0 Station Details	9
4.1 W.H.O.I. Ground Station	9
4.2 Portable/Remote Station	11
5.0 Results	13
5.1 Upload Test	14
5.2 Conclusions	17
6.0 Recommendations	17
7.0 Acknowledgements	18
8.0 References	18
9.0 Appendix	19

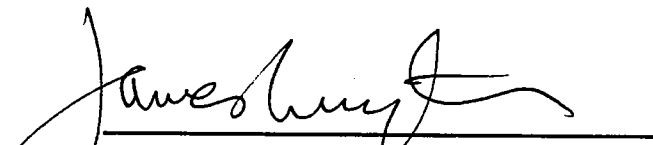
List of Figures

		page
Fig. 1a	W.H.O.I. Ground Station	10
Fig. 1b	Experimental Station	10
Fig. 2	Portable / Remote Station	12
Fig. 3	Remote Station Specifications	12

List of Tables

Table 1	Uo-22 Visibility Table	8
Table 2	Results from Uplink Data Test	15
Table 3	25 Watt Data Summary	15
Table 4	5 Watt Data Summary	16

1.0 Abstract

The intent of this project was to test and evaluate a new data collection concept; that of utilizing a "store and forward" message system in a low earth orbiting satellite, and to determine its suitability for oceanographic data telemetry. This new generation of satellites, dubbed "MicroSats" because of their small size (a 9 in. cube), was developed by the Amateur Radio Satellite Corporation (AMSAT) to complement the existing HF and VHF terrestrial Packet data switching networks.

2.0 Overview

The MicroSat concept offers several potential advantages over the existing data collection systems commonly available to the oceanographic community, namely ARGOS and GOES: higher data rates are possible; the data are error corrected, and two-way communications are inherent to the system. MicroSats offer global coverage but do not, at this time, provide any information on platform position. The original set of MicroSats was designed by AMSAT and launched on January 22, 1990; they utilize a 1200 baud FSK uplink and a PSK downlink. These satellites were deemed not suitable for remote platform applications, see section 5.0. I am presently working with a different series of MicroSats designed by the University of Surrey (AMSAT-UK); these were launched in July 1991 and are referred to as UoSATS. These satellites operate at 9600 baud FSK on the uplink and downlink as compared to a 400 baud ARGOS transmitter.

2.1 Purpose of Project

The general intent is to develop a mechanism with which to gather in situ data from remote autonomous platforms in the world's oceans and to disseminate the data in a timely and efficient way. Other systems are capable of performing this service but are data capacity limited (Ref.1). The present benchmark is the ARGOS system; data throughput has been shown to be .1 bits/s or approximately 1 Kbyte of data per day per platform ID.

Towards this goal we proposed to design, construct, and test two prototype satellite ground stations: one a data collection/control ground station, and the second a simple remote platform. These stations were constructed using commercially available equipment which was modified as necessary to meet the needs of the system. Experience has shown downloading of data from the satel-

lites to be a relatively easy task; nearly 1Mb of data can be downloaded daily from a station with directional satellite tracking antennas (personal communication, M. Kanawati - Interferometrics, Inc.). As a result, most of the efforts to date have concentrated on establishing a figure of merit for the amount of data which can be uploaded to the satellite. This test, to fall within the guidelines of the Amateur Radio Service, could not contain data of any commercial interest. Our uplink efforts were directed towards what might be expected of a remote platform in the field; hence, these tests were RF power and antenna limited. Only modest power and antennas were considered and utilized.

2.2 Satellite Operating System

In order to understand the constraints on our system parameters, one must have a basic understanding of the MicroSat operating system. The system is based upon a digital "store and forward" BBS (Bulletin Board Server) communications satellite in low earth orbit (LEO). The data are transmitted in packets utilizing the AX.25 protocol. As the satellite passes within the field of view of the ground station, users can uplink or downlink files created on a personal computer. The on-board memory of the satellite consists of a 2 Kb boot ROM, 256 Kb of error detecting and correcting (EDAC) program RAM, and 8 Mb (min.) of static RAM for message storage. This 8Mb represents enough RAM to store the equivalent of 250000, 256 bit ARGOS transmissions! In the amateur application the satellite can support as many as 22 users at 9600 baud, 2 in the active BBS for uploads per on-board receiver (there are two but only one is active at this time); and as many as 20 on the BBS download side. On-board data files are stored for four days before being flushed from memory. The files for uploading must have headers appended to the file prior to initiating

the uploads. Throughout the orbit the satellite is "broadcasting" its status; in the BBS uplink mode, ground stations must wait until they see an OPEN frame from the BBS before attempting to initiate a CONNECT to the satellite. When both of the available uplink channels are occupied, the satellite broadcast indicates FULL. The initial software release did not wait for the OPEN frame resulting in a number of uplink collisions and poor data throughput. The satellite operates on a random-access basis; whenever two stations are connected, the satellite generates a BUSY frame sending those stations, which are still attempting to CONNECT, back to the WAIT state for an OPEN frame. Given the limited number of users, less than 1000 globally, this system works quite well. In the CONNECTED mode, data is passed to the satellite in packets as described in the AX.25 protocol (Ref.2) level 2. The uplink is adaptive; if the link margin is good, the number of frames sent is increased to a preset maximum as long as the appropriate acknowledgement (ACK) is received from the satellite.

The BBS download mode operates in a similar fashion with the exception that it supports a greater number of users. The downloaded files are sent in what is referred to as "broadcast protocol"; that is, they are not sent to a particular station. Each station decides (the operator flags) which files it will look for and capture on the downlink. It will then send a message to the satellite to start the broadcast of a particular file. If that file was previously requested by another station the satellite will cue the station for the next selection. As files are captured, the ground station retains those selected to be of interest. It also maintains a list of HOLES - the missing pieces of the files - and requests the satellite to send FILLS for the HOLES until the file is complete. In this manner the number of times a general interest bulletin is downloaded is minimized. As you can see, when the satel-

lite is overhead it is quite busy!

There is a third mode of operation, which for amateur applications has been turned off as it is not uplink efficient. This is the digipeater or "bent-pipe" store and forward capability. This mode permits real time communications between two stations as long as they are within the satellite footprint.

There are a number of possible satellite passes each day. Table 1 is a prediction for Azimuth and Elevation vs time for the amateur satellite of interest (Uo-22) for my location at Woods Hole (41-30 N, 70-40 W). Note, there are four useful passes with elevations greater than 10 degrees (my horizon); two are quite good with elevations approaching 70 degrees. Stations with tracking antennas can access the satellite as it comes over the horizon, and, therefore, can utilize a greater percentage of the pass. The satellite footprint is on the order of 5000 Km. in diameter.

3.0 Unanticipated Problems

When this project was first considered, the satellites had not been launched. The first group of four MicroSat spacecraft were launched on January 22, 1990. These satellites were designed and constructed by AMSAT, the Amateur Radio Satellite Corporation. AMSAT is supported by a group of amateur radio enthusiasts who communicate through the amateur satellites; they are unpaid volunteers who lend their expertise and enthusiasm to these development efforts on behalf of amateurs worldwide.

We encountered a number of unforeseen problems, some of these were:

- a. Because the AMSAT effort is an avocation for those principals involved - not a vocation - the BBS servers on board the satellites did not come "on-line" until November 1990, almost a year after launch. Over the next six or

Table 1: Uo-22 Visibility Table

136. UO-22									
Date/Time EDT	Azim/Elev	Range	Lat	Long	Doppler	Phs/M	Offp		
02JUN92 011128	277/ -0	3238	+39	-106			33		
-----end of pass-----									
02JUN92 095537	41/ -0	3288	+58	-36			92		
02JUN92 095737	55/ 4	2824	+51	-40	+5631		97		
02JUN92 095937	73/ 7	2536	+44	-43	+3505		102		
02JUN92 100137	94/ 8	2490	+37	-45	+552		107		
02JUN92 100337	113/ 5	2702	+30	-47	-2576		112		
02JUN92 100537	129/ 1	3118	+23	-49	-5052		117		
-----end of pass-----									
02JUN92 113313	14/ -0	3296	+67	-54			85		
02JUN92 113513	16/ 8	2495	+60	-60	+9733		90		
02JUN92 113713	18/ 21	1717	+53	-64	+9453		95		
02JUN92 113913	26/ 46	1042	+46	-67	+8192		100		
02JUN92 114113	153/ 72	821	+39	-69	+2690		105		
02JUN92 114313	185/ 32	1310	+32	-72	-5947		110		
02JUN92 114513	189/ 14	2050	+25	-73	-8981		116		
02JUN92 114713	191/ 4	2844	+18	-75	-9648		121		
-----end of pass-----									
02JUN92 131305	355/ -0	3291	+68	-77			84		
02JUN92 131505	343/ 6	2685	+62	-84	+7360		89		
02JUN92 131705	326/ 12	2234	+55	-88	+5483		94		
02JUN92 131905	301/ 14	2050	+48	-91	+2230		99		

136. UO-22									
Date/Time EDT	Azim/Elev	Range	Lat	Long	Doppler	Phs/M	Offp		
02JUN92 132105	276/ 12	2204	+41	-94	-1875		104		
02JUN92 132305	258/ 6	2635	+34	-96	-5233		110		
02JUN92 132505	246/ 0	3228	+27	-98	-7201		115		
-----end of pass-----									
02JUN92 211122	115/ -0	3244	+26	-43			26		
02JUN92 211322	103/ 6	2642	+33	-45	+7312		31		
02JUN92 211522	85/ 12	2199	+41	-47	+5391		36		
02JUN92 211722	60/ 14	2030	+48	-50	+2054		41		
02JUN92 211922	35/ 12	2203	+55	-53	-2106		46		
02JUN92 212122	17/ 6	2650	+61	-58	-5439		51		
02JUN92 212322	5/ 0	3256	+68	-64	-7360		56		
-----end of pass-----									
02JUN92 224823	169/ -0	3235	+15	-66			17		
02JUN92 225023	171/ 8	2430	+22	-67	+9772		23		
02JUN92 225223	173/ 21	1653	+29	-69	+9448		28		
02JUN92 225423	183/ 48	994	+36	-71	+8010		33		
02JUN92 225623	312/ 67	836	+43	-73	+1911		38		
02JUN92 225823	338/ 30	1368	+50	-76	-6458		43		
02JUN92 230023	343/ 13	2117	+57	-80	-9100		48		
02JUN92 230223	345/ 3	2913	+64	-85	-9672		53		
-----end of pass-----									
03JUN92 003034	229/ -0	3231	+21	-92			22		

seven months there were a number of satellite software crashes which sent the birds into a ROM-safe mode. Ultimately the intervals between ROM-safe modes increased, and the satellites gradually moved into an operational phase.

b. The user software necessary to access the satellites did not initially support unattended operations. The system which is in place at this time does not handle multiple files in a particularly efficient manner; it loops through a .BAT file several times as it manipulates the files to be uploaded. Clearly the early emphasis was placed in getting the satellites into orbit; software development followed at a slower pace. In all fairness, given the limited resources available, they (AMSAT) have a remarkable track record for success.

c. The number of satellite changes which we have made were not considered initially. We moved from AO-16 to Uo-14 and are presently operating on Uo-22 which was launched in July 1991. We are in the process of moving back to Uo-14 on an experimental channel outside of and adjacent to the amateur allocated frequencies. The details of these moves will be discussed in a later section.

4.0 Station Details

4.1 W.H.O.I. Ground Station

The W.H.O.I. ground station consists of modified equipment intended for the amateur radio service, see Figure 1a. The upgrades necessary for the non-amateur use of the station are noted in Figure 1b, as the ICOM transceivers will not operate below 430 Mhz. on the experimental Uo-14 channel.

The ground station transmits in the VHF range and receives in the UHF range. The data output from the receiver is tapped at the discriminator, data input to the transmitter is connected directly to the modulator; digital FSK is used on the uplink and downlink. The received signal is shifted several Khz. by the Doppler effect as the satellite passes overhead. The computer, in

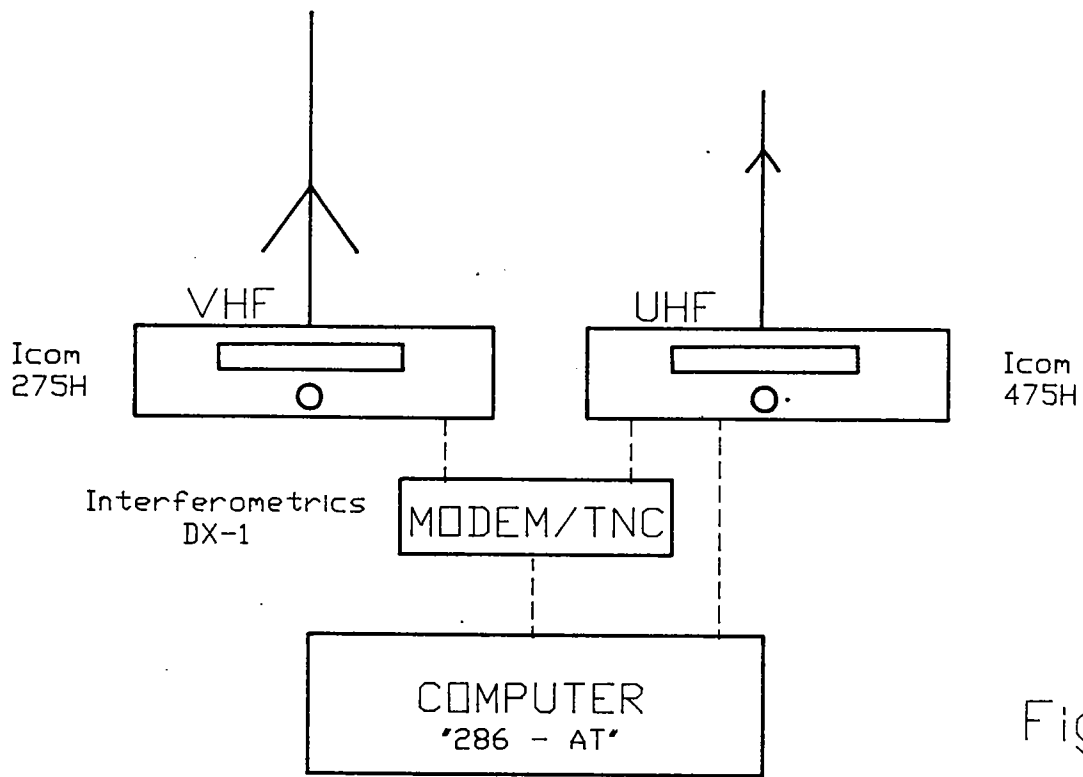

Fig. 1a

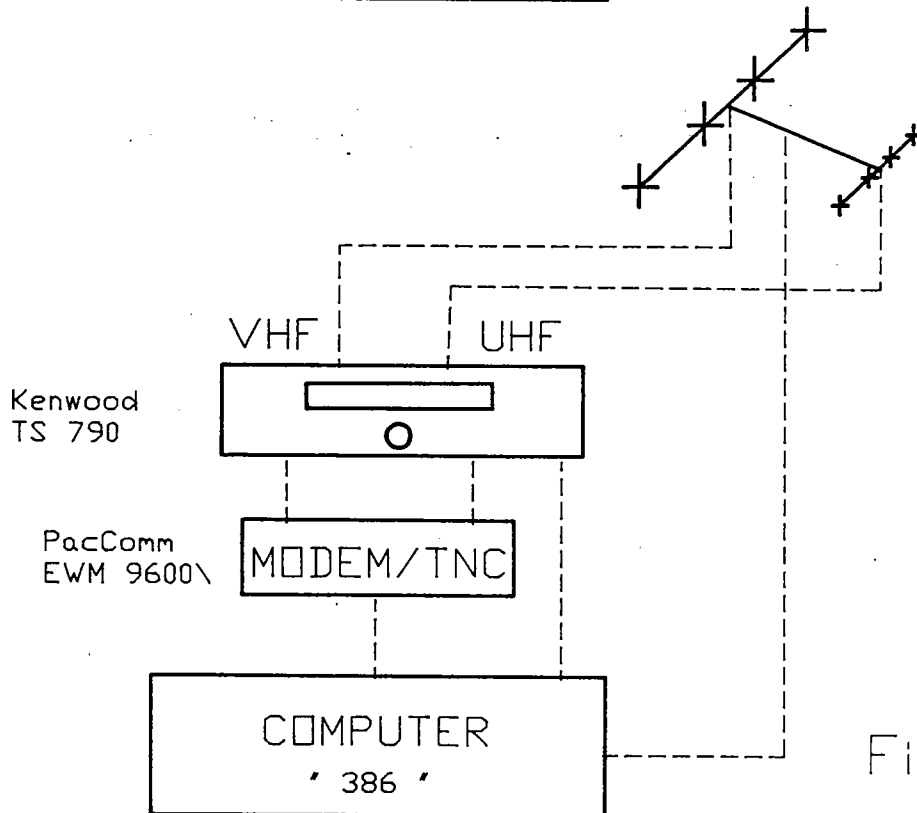

Fig. 1b

addition to running the satellite communications software, is tracking the satellite in real time. It communicates serially with the UHF receiver, continuously tuning the receiver over the duration of the pass to compensate for the Doppler shifted frequency. The 9600 baud modem/tnc (terminal node controller) is a standard off-the-shelf component designed for use with the satellites. In this station the antennas are simple verticals, typical of what might be mounted on a remote platform. The station software is an updated version of the standard programs developed for the amateur service.

Figure 1b depicts the modifications necessary for the experimental application. The transceivers are integrated into a single unit (Doppler compensated); and the computer, in addition to its other functions, now controls the antenna azimuth/elevation rotator to track the satellite for the duration of the pass. The standard amateur upload/download software has been automated by means of various .BAT files. However, this inefficient method may be replaced by a file management system under development at V.I.T.A. (Volunteers In Technical Assistance.)

4.2 Portable/Remote Station

This station was assembled for simulation purposes only; it is shown in Figure 2. It consists of two modified commercial UHF/VHF telemetry modules manufactured by the E.F. Johnson Co., vertical antennas for the VHF uplink and the UHF downlink, a low noise receiver preamplifier, and the modem/tnc. The modules are quite small, each measuring 4.75 x 3.08 x 1.2 inches. The appendix details the modifications which are necessary to the transmitter and receiver for this application. The computer in this case was a portable PC; in an actual application this would be replaced by the system controller or a single card PC as necessary. The specifications for the remote station are

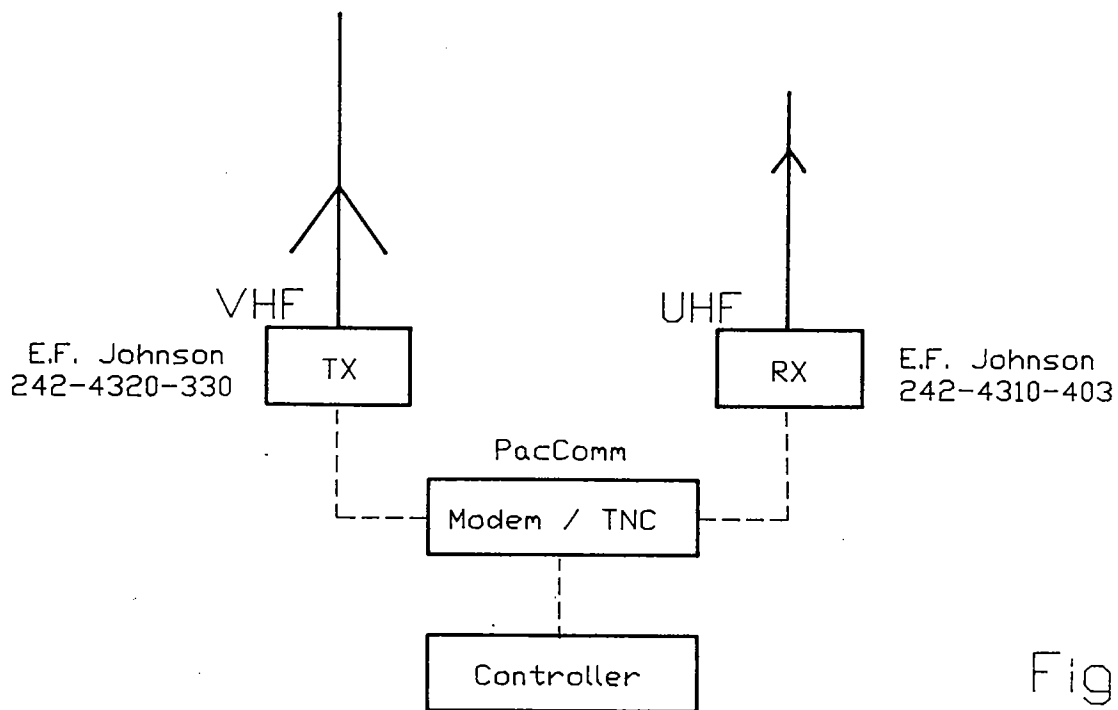

Fig. 2

Remote Station Specifications

Rx Freq. 403 - 430 Mhz.
 Rx Power Nominal 10 ma. At 10 Volts

Tx Freq. 142 - 150 Mhz.
 Tx Power 4.5 Watts, 14 Volts at 1.0 Amp
 3.2 Watts, 12 Volts at .8 Amp
 2.4 Watts, 10 Volts at .7 Amp

TNC Power 55 ma. at 10 Volts

Fig. 3

given in Figure 3; the limiting factor of the remote station is the quiescent power consumption. A number of the receiver modifications are intended to reduce the current required by the receiver. In a specific application the system controller would power switch on the receiver only when a satellite pass was expected. The squelch output from the receiver can be monitored to detect the presence of a signal. After a positive squelch indication, power to the modem/tnc and the transmitter would be enabled for the CONNECT sequence.

5.0 Results

During this time a number of different approaches to LEO satellite operations were tried. Our emphasis was focused on what would be practical for a remote platform. We knew from previous experience that a ground station could effectively utilize the technology. We also made several contacts in the industry, most notably, Mr. Lorenzini and Mr. Kanawati (Interferometrics, Inc.); and Mr. Garriott and Mr. Rosenberg (V.I.T.A.). Interferometrics holds the exclusive license to market the AMSAT design for commercial purposes, and V.I.T.A. has been testing the "store and forward" concept on Uo-14 for improving communications with its personnel in remote areas.

Our initial attempts with the AMSAT MicroSats were made using AO-16, one of the FSK uplink/PSK downlink satellites. The PSK downlink requires the use of a narrowband, single sideband UHF receiving system. This type of receiving system (as compared to an FM receiver) is complex (it requires a number of stages for detection) and not particularly energy efficient. It has the advantage of being able to detect very low level signals. However, this advantage is offset by the need to control the Doppler shifted frequency to within +/- 100 Hz. on the downlink. This frequency control is generated by the PLL (Phase lock Loop) in the modem; it is then used to step the transceiver fre-

quency through the satellite pass. It became apparent in the early stages of testing that this system would not be suitable for a remote platform with a limited power budget. One of the other satellites launched at the same time as AO-16 is DO-17; DO-17 is referred to as DOVE for Digital On-board Voice Recorder. This is an educational satellite intended to give school children "hands-on" experience with this new technology. It broadcasts its telemetry on an FSK downlink at 1200 baud, using the same protocol as terrestrial packet stations. Compared to AO-16 with its attendant tuning problems, monitoring DO-17 on the downlink was remarkably easy!

Uo-14, one of the Surrey satellites, which was also set on the initial MicroSat launch, utilizes a two way 9600 baud FSK link. It was followed later by Uo-22 in July 1991. In February 1992, Uo-14 was shifted outside the amateur band and the amateur operations were consolidated on Uo-22. The bulk of our tests and the results presented here were generated on Uo-22.

5.1 Upload Test

Our objective was to determine the data throughput capability of the MicroSat system, from a remote platform application point of view. We settled on an RF uplink power of 25 watts ERP (Effective Radiated Power) - the product of output power and the antenna gain - into an omnidirectional antenna system. A pair of 3/4 wavelength vertical antennas were chosen on the basis of their simplicity; also, their 37 degree upward major lobe is well suited for satellite communications. A test file of 11.7 Kbytes was generated and copied numerous times in preparation for uploading. The test was repeated a second time at a power of 5 watts (ERP) which represents a practical level for a battery powered system. Data for the period 30 May 92 through 6 June 92 are

presented here as they are representative of the numerous files collected to date.

Table 2 - Results From Upload Data Test

DATE	POWER (ERP)	DATA (Kb/day)
5/30	25 watts	92.1
5/31	25 "	95.3
6/1	5 watts	37 (tracking failed)
6/2	5 "	61
6/3	5 "	63.7
6/4	5 "	47.4
6/5	5 "	53.4
6/6	5 "	83.2

As noted earlier, there are three to four useful passes for Uo-22 each day. I have looked at the data from a per-PASS as well as a per-DAY basis, as summarized in Tables 3 and Table 4.

Table 3 - 25 Watt (ERP) Data Summary

	Sample	per Pass	per Day
Mean	25 Watts	20.5 Kb	93.7 Kb
Std. Dev.	25 Watts	9.1	1.1

Data uplinked ranged from 9.4 to 32.6 Kb per pass.

Table 4 - 5 (ERP) Watt Data Summary

	Sample	per Pass	per Day
Mean	5 Watts	14.15Kb	61.7Kb
Std. Dev.	5 Watts	10.5	12.16

Data uplinked ranged from 1.5 to 35 Kb per pass.

The details of the passes are quite interesting. A condensed version of my notes taken during the 1500 GMT pass on 6/3/92 is shown below.

Notes	Comments
15:00:33	satellite at 10 degrees
15:02:01 OPEN	logged in
15:02:34 DISCONNECTED	Signal faded, 2784 Bytes uploaded, (84B/s)
15:03:42 OPEN	logged in
15:05:00	file uploaded, 11784 Bytes (150B/s)
15:05:53	continue uploading
15:07:20 DISCONNECTED	file uploaded, 11784 Bytes (135B/s)
15:09:50	out of range 10 degrees

This represents one of the better passes at the 5 watt power level. In excess of 26 Kbytes of data was successfully uplinked during this pass. The pass was 497 seconds in duration, of which we were actively sending data for only 198 seconds or approximately 39% of the pass!

Upload rates in excess of 200 Bytes/sec. have been observed from our station. Rates in excess of 400 Bytes/sec. have been observed on the non-amateur satellite (personal communications - Mr. Rosenberg).

The Portable/Remote station was pressed into service when we experienced a hard disk failure on the ground station. The results here are again encouraging; we generally uploaded a few Kbytes of data at a power level of 2 watts

ERP each pass and captured more than 150 Kb of data during downlink monitoring - certainly more than necessary to send a command to a remote platform.

5.2 Conclusions

The ARGOS benchmark is 1 Kb/day (.1 bits/sec) with two operational satellites. Utilizing the "store and forward" technique, we have demonstrated a 60 to 90 times increase in throughput capability (5.7-8.7 bits/sec) with a single satellite.

There is a large variation in the data passed on a per-pass basis; however, the daily results are more consistent. The competition on the amateur satellite is very intense. Our 25 and 5 watt uplink signals are in direct competition with other stations operating with uplink powers of 500-1000 watts ERP. Our best "5 watt day" observed was an upload of 83 Kb!

Clearly we fell short of the 20 bits/second we had hoped to average when we submitted our proposal, but we occupy generally less than 40% of the available uplink time. Had we been able to capture the satellite from the other "high power" users, I believe we would approach the 20 bits/sec. mark.

6.0 Recommendations

There have been a number of LEO satellite systems proposed in the commercial sector since the success of the AMSAT MicroSats. Frequency allocations for LEO satellite operations were approved at the recent WARC (World Administrative Radio Conference); however, these systems are still a number of years away from becoming fully operational.

The results documented in this report are encouraging but not conclusive, since several questions remain unanswered:

- a. Can we achieve 20 bits/sec. in a field of low power uplinks?
- b. Would a polled (as opposed to a random access) system improve the data throughput?
- c. Can we adapt such a system to an autonomous platform?

Hopefully we can answer some of these questions in a timely way; as time permits I intend to repeat these tests on Uo-14 at the invitation of V.I.T.A. The relatively low cost of the MicroSat makes it a potential option for those programs which feel constrained by the system ARGOS data capacity. This new technology complements rather than competes with the existing systems.

7.0 Acknowledgements

I wish to acknowledge the support of Dr. Thomas Curtin of the Office of Naval Research (ONR), and our contacts in industry, Mr. Lorenzini and Mr. Kanawati of Interferometrics, Inc.; and Mr. Garriott and Mr. Rosenberg of V.I.T.A. All have been supportive of our endeavors.

Funding for this report has been provided under the Office of Naval Research Contract Number, N00014-90-C-0013.

8.0 References

- (1) Briscoe M.G., and D.E. Frye, 1987
Motivations and Methods for Ocean Data Telemetry
Marine Technological Society Journal
Vol. 21, No.2, Pg. 42-57

(2) Proceedings - 7th Computer Networking Conference
American Radio Relay League, Newington, Ct.
October 1, 1988

9.0 Appendix

It is recommended that those interested in these particular models obtain, from the manufacturer, the service manuals for the modules indicated. One should refer to the manuals for the detailed schematic changes referenced herein. A basic understanding of UHF receiver and VHF transmitter operating principles is assumed.

a. E.F. Johnson model 242-4310-403 Rx Telemetry Module

Several changes are necessary in the receiver; most are required to minimize the quiescent current drain of the receiver. The receiver block diagram is fairly typical of most receivers intended for telemetry applications. The second set of changes is made to increase the I.F. bandwidth to compensate for the Doppler shift experienced on the downlink.

Detailed changes	Comments
1. Remove Q500, Q501	Disables squelch detect invertors
2. Remove R3	Disables High Z audio amplifier
3. Remove Z1a, Z1b	I.F. Crystal filters, replace with Piezo Technology, 5591R
4. Remove Z200	Second I.F. filter, replace with MuRata CFU 455D
5. Change L.O. crystal Y101 as required.	

Wire from connector J1 as follows:

pin	use
2 (green)	wide band Data Out (to TNC)
5 (red)	+V, 10 to 14 volts
9 (black)	Ground

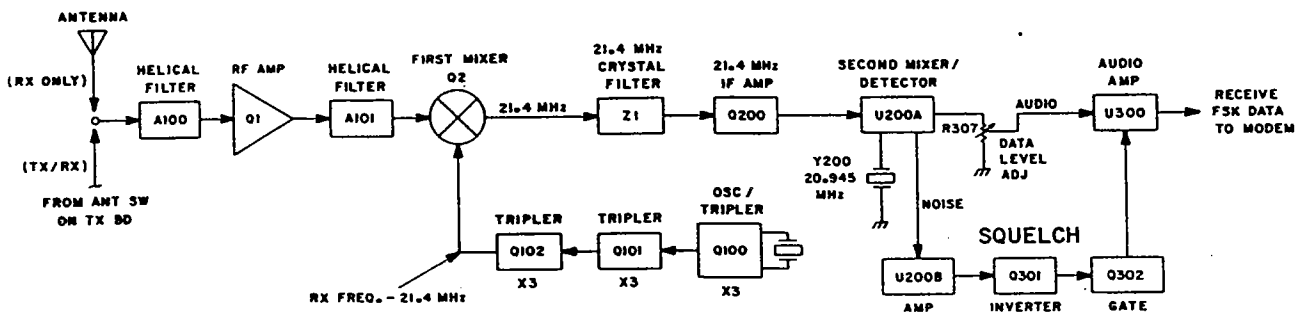

RECEIVER BLOCK DIAGRAM

b. E.F. Johnson model 242-3420-330 Tx Telemetry Module

The modifications to the transmitter are minimal; only the audio module is disabled. Provisions are made to drive the FSK modulator direct from the TNC. Operation of the transmitter is straightforward as it is crystal controlled. Refer to the block diagram.

Detailed changes	Comments
1. Open trace to A600, pin3	Removes D.C. from module
2. Open trace from A600, pin 7	Isolates audio input
3. Jumper J1-8 to R401 high	Modulator in from TNC

Wire from connector J1 as follows:

pin	use
5 (red)	+V, 10 to 14 volts
6 (violet)	Tx Key (to gnd.)
8 (green)	Data In (from TNC)
9 (black)	Ground

Interconnections are primarily power and ground; TNC connections are as noted. Refer to the TNC instruction manual for details.

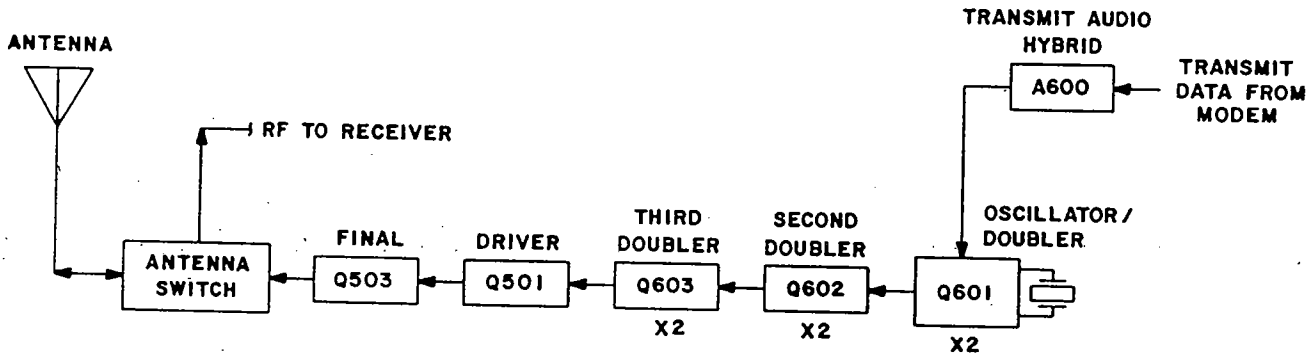

TRANSMITTER BOARD BLOCK DIAGRAM

DOCUMENT LIBRARY

March 11, 1991

Distribution List for Technical Report Exchange

Attn: Stella Sanchez-Wade
Documents Section
Scripps Institution of Oceanography
Library, Mail Code C-075C
La Jolla, CA 92093

Hancock Library of Biology &
Oceanography
Alan Hancock Laboratory
University of Southern California
University Park
Los Angeles, CA 90089-0371

Gifts & Exchanges
Library
Bedford Institute of Oceanography
P.O. Box 1006
Dartmouth, NS, B2Y 4A2, CANADA

Office of the International
Ice Patrol
c/o Coast Guard R & D Center
Avery Point
Groton, CT 06340

NOAA/EDIS Miami Library Center
4301 Rickenbacker Causeway
Miami, FL 33149

Library
Skidaway Institute of Oceanography
P.O. Box 13687
Savannah, GA 31416

Institute of Geophysics
University of Hawaii
Library Room 252
2525 Correa Road
Honolulu, HI 96822

Marine Resources Information Center
Building E38-320
MIT
Cambridge, MA 02139

Library
Lamont-Doherty Geological
Observatory
Columbia University
Palisades, NY 10964

Library
Serials Department
Oregon State University
Corvallis, OR 97331

Pell Marine Science Library
University of Rhode Island
Narragansett Bay Campus
Narragansett, RI 02882

Working Collection
Texas A&M University
Dept. of Oceanography
College Station, TX 77843

Library
Virginia Institute of Marine Science
Gloucester Point, VA 23062

Fisheries-Oceanography Library
151 Oceanography Teaching Bldg.
University of Washington
Seattle, WA 98195

Library
R.S.M.A.S.
University of Miami
4600 Rickenbacker Causeway
Miami, FL 33149

Maury Oceanographic Library
Naval Oceanographic Office
Stennis Space Center
NSTL, MS 39522-5001

Marine Sciences Collection
Mayaguez Campus Library
University of Puerto Rico
Mayaguez, Puerto Rico 00708

Library
Institute of Oceanographic Sciences
Deacon Laboratory
Wormley, Godalming
Surrey GU8 5UB
UNITED KINGDOM

The Librarian
CSIRO Marine Laboratories
G.P.O. Box 1538
Hobart, Tasmania
AUSTRALIA 7001

Library
Proudman Oceanographic Laboratory
Bidston Observatory
Birkenhead
Merseyside L43 7 RA
UNITED KINGDOM

REPORT DOCUMENTATION PAGE	1. REPORT NO. WHOI-92-25	2.	3. Recipient's Accession No.
4. Title and Subtitle Status Report on MicroSat Data Telemetry			5. Report Date June 1992
7. Author(s) James R. Valdes			6.
9. Performing Organization Name and Address Woods Hole Oceanographic Institution Woods Hole, Massachusetts 02543			8. Performing Organization Rept. No. WHOI-92-25
12. Sponsoring Organization Name and Address Office of Naval Research			10. Project/Task/Work Unit No.
15. Supplementary Notes This report should be cited as: Woods Hole Oceanog. Inst. Tech. Rept., WHOI-92-25.			11. Contract(C) or Grant(G) No. (C) N00014-90-0013 (G)
16. Abstract (Limit: 200 words) The intent of this project was to test and evaluate a new data collection concept; that of utilizing a "store and forward" message system in a low earth orbiting satellite, and to determine its suitability for oceanographic data telemetry. This new generation of satellites, dubbed "MicroSats" because of their small size (a 9 in. cube), was developed by the Amateur Radio Satellite Corporation (AMSAT) to complement the existing HF and VHG terrestrial Packet data switching networks.			13. Type of Report & Period Covered Technical Report
17. Document Analysis			14.
a. Descriptors satellite telemetry LEO satellites store and forward			
b. Identifiers/Open-Ended Terms			
c. COSATI Field/Group			
18. Availability Statement Approved for public release; distribution unlimited.		19. Security Class (This Report) UNCLASSIFIED	21. No. of Pages 21
		20. Security Class (This Page)	22. Price