

WHOI-88-54

(repl.) C. 2

**Woods Hole
Oceanographic
Institution**



DOCUMENT
LIBRARY
Woods Hole Oceanographic
Institution

**A Modified Wire Clamp System for
Thirty-Liter Niskin Bottles**

by

T.R. Hammar, P.L. Sachs and M.P. Bacon

November 1988

Technical Report

Funding was provided by the National Science Foundation
under grant Number OCE 84-17910, and by the United States Department of Energy
under contract Number DE-AC02-76EV03566.

Approved for public release; distribution unlimited.

WHOI-88-54

**A Modified Wire Clamp System for
Thirty-Liter Niskin Bottles**

by

T.R. Hammar, P.L. Sachs and M.P. Bacon

Woods Hole Oceanographic Institution
Woods Hole, Massachusetts 02543

November 1988

DOCUMENT
LIBRARY
Woods Hole Oceanographic
Institution

Technical Report

Funding was provided by the National Science Foundation
under grant Number OCE 84-17910, and by the
United States Department of Energy under
contract Number DE-AC02-76EV03566.

Reproduction in whole or in part is permitted for any purpose of the
United States Government. This report should be cited as:
Woods Hole Oceanog. Inst. Tech. Rept., WHOI-88-54.

Approved for publication; distribution unlimited.

Approved for Distribution:

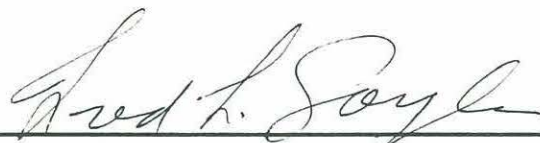

Frederick L. Sayles, Chairman
Department of Chemistry



A MODIFIED WIRE CLAMP SYSTEM FOR THIRTY-LITER NISKIN BOTTLES

T. R. Hammar, P. L. Sachs and M. P. Bacon

ABSTRACT

A modified clamping system for 30-liter Niskin bottles, consisting of a wire stop, a socket block, and a toggle clamp, has been designed and has been tested at sea. The modified system makes deployment and recovery of the Niskin bottles considerably easier than it is with the standard clamps.

INTRODUCTION

The 30-liter Niskin bottle is a popular sampling device for biological and chemical investigations. When full of seawater, however, it weighs about 40 kg and is difficult to handle. Removal of full samplers from the hydrowire is particularly awkward. Overhead lifting systems can be used to help support the weight while the clamps are being loosened, but they tend to cock the sampler at an angle on the wire and jam one or both of the clamps. We have designed a clamping system for 30-liter Niskin bottles that makes deployment and recovery easier and faster. The system has the additional advantage that no tools are needed to attach the sampler to the wire. The standard clamp, on the other hand, includes a wing nut that must be tightened with a wrench, and damage can result if excessive torque is applied. The modified clamp system (Fig. 1a) consists of a wire stop, a socket block, and a toggle clamp. We believe that the design could easily be adapted to Niskin bottles of other sizes, but this has not actually been done.

TECHNICAL DESCRIPTION

The wire stop is a book-type clamp made of 6061-T6 aluminum (Figs. 1b, 2a). Two halves form a hinged block which measures 5 x 5 x 3.5 cm with a 1.25-cm diameter pin extending 1.75 cm above the top of the clamp. This pin is concentric with the hydro wire and is used to position the lower part of the Niskin bottle with respect to the wire. The two halves are hinged together with a 0.6-cm stainless-steel pin knurled on one end. To tighten the wire stop onto the wire, a 1/2"-20 stainless steel bolt is modified and secured to one half of the clamp with another 0.6-cm stainless-steel pin in such a way that the clamp can be pivoted around the wire, and a 5-cm diameter knurled delrin knob with threads to match the bolt is tightened by hand to secure the clamp (Figs. 1b, 2b). The hinges and pins are lubricated during assembly with Anti-Corrosion Grease (Part #C-92-78736, Mercury Marine, Division of Brunswick Corp., Fond du Lac, Wisconsin, available through Mercury Marine dealers). A half-sized prototype version of this clamp was tested in a tensile machine and was found to hold in excess of 2200 kg before slippage occurred. In an identical test the standard Niskin clamp began to slip at 1700-1800 kg.

An aluminum block attached to the lower part of the Niskin sampler with three 1/4"-20 flat head machine screws has a socket which mates with the concentric pin of the wire stop (Figs. 1b, 2c). The block measures 5 x 4.5 x 1.9 cm and the socket is aligned with the hydrowire slot on the original clamp so that the proper spatial relationship between the sampler and the wire is maintained. The block extends beyond the original clamp to help capture the wire and guide the socket over the pin.

The third component is the aluminum over-the-center toggle clamp. This consists of a 3.8 cm wide, 10.5 cm long handle which utilizes cam action (Figs. 1c, 1d, 2d). The head of the clamp is hollowed out to accommodate a stainless steel swivel block. This is mounted to the handle with two stainless-steel shoulder screws (P/N PL28-3, Winfred M. Berg, Inc., 499 Ocean Avenue, E. Rockaway, N.J. 11518, (516) 599-5010). There are 1/2"-20 threads tapped through the swivel to accommodate a 1/2"-20 x 6.3 cm stainless-steel bolt which has been modified to duplicate the standard Niskin clamp bolt. Nylon inserts are placed between the shoulder screws and the 1/2"-20 bolt so that the handle does not spin freely on the bolt (Fig. 2e). The throw of the cam on the handle is 2.2 cm and is equivalent to the normal tightening distance on the Niskin bolt. Tension is adjustable in increments of less than 0.7 mm by turning the handle and swivel block in or out on the clamping bolt.

PERFORMANCE AT SEA

The clamps have been used routinely on a number of oceanographic voyages. They perform very well and have been well accepted by those who have used them. The wire stop functions to carry the load after the toggle is released so little stress is placed on the workers until they are ready to lift and remove the bottle from the pin and away from the wire. The need to hold the weight of the sampler while the second wing nut is released has been eliminated. The additional hardware attached to the Niskin samplers has not created any malfunctioning of the sampler's release mechanisms.

COST

Blank molds for the toggle and wire stop halves are sand cast at Prue Foundry, Inc., Dennis, MA (508) 385-3011 (\$22/toggle, \$22/2-pc. wire stop). Finish machining for these and all the machining for the socket block are performed at WHOI. Total cost for each clamp installed is between \$200 and \$250.

Acknowledgement

We are grateful to R. A. Belastock and A. P. Fleer for their assistance in testing the clamp system at sea.

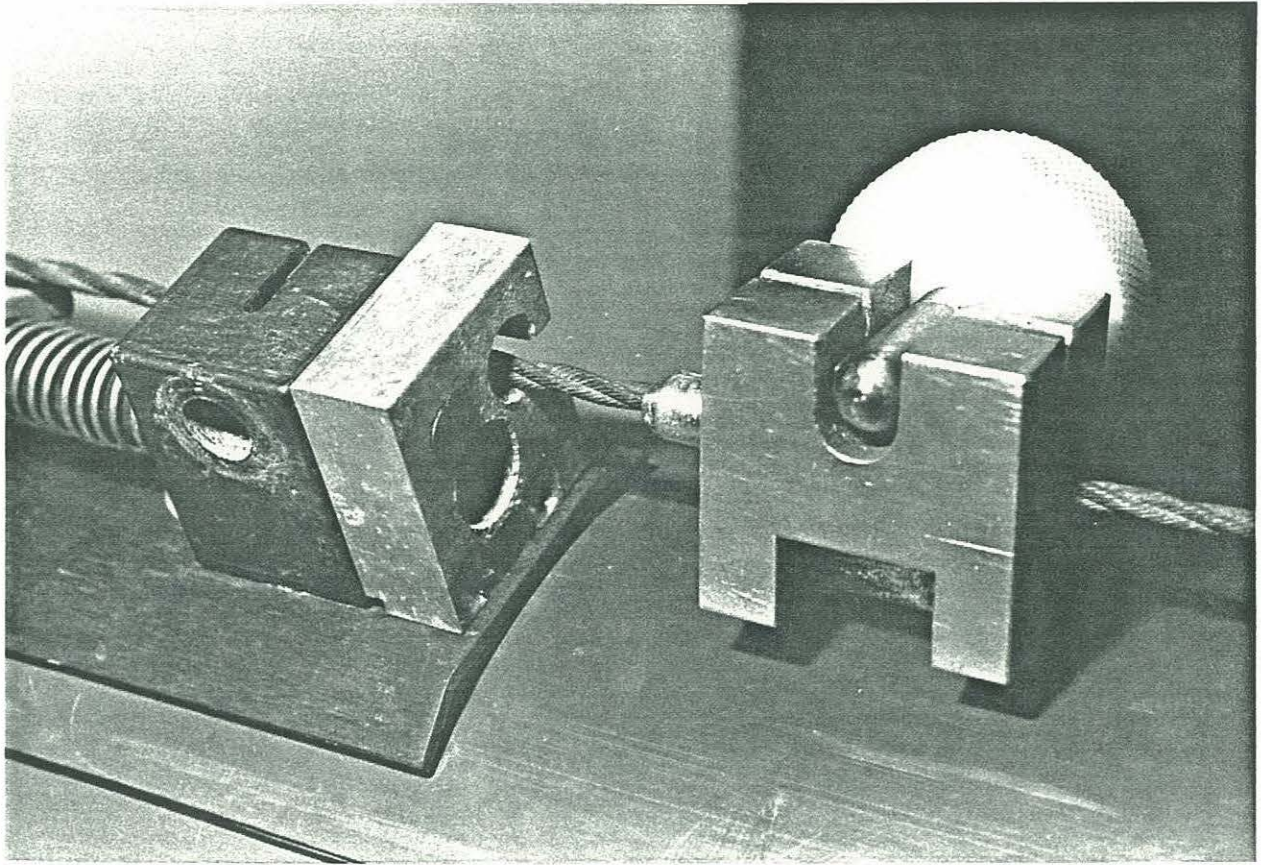

Figure 1b. Wire stop and mating aluminum block.

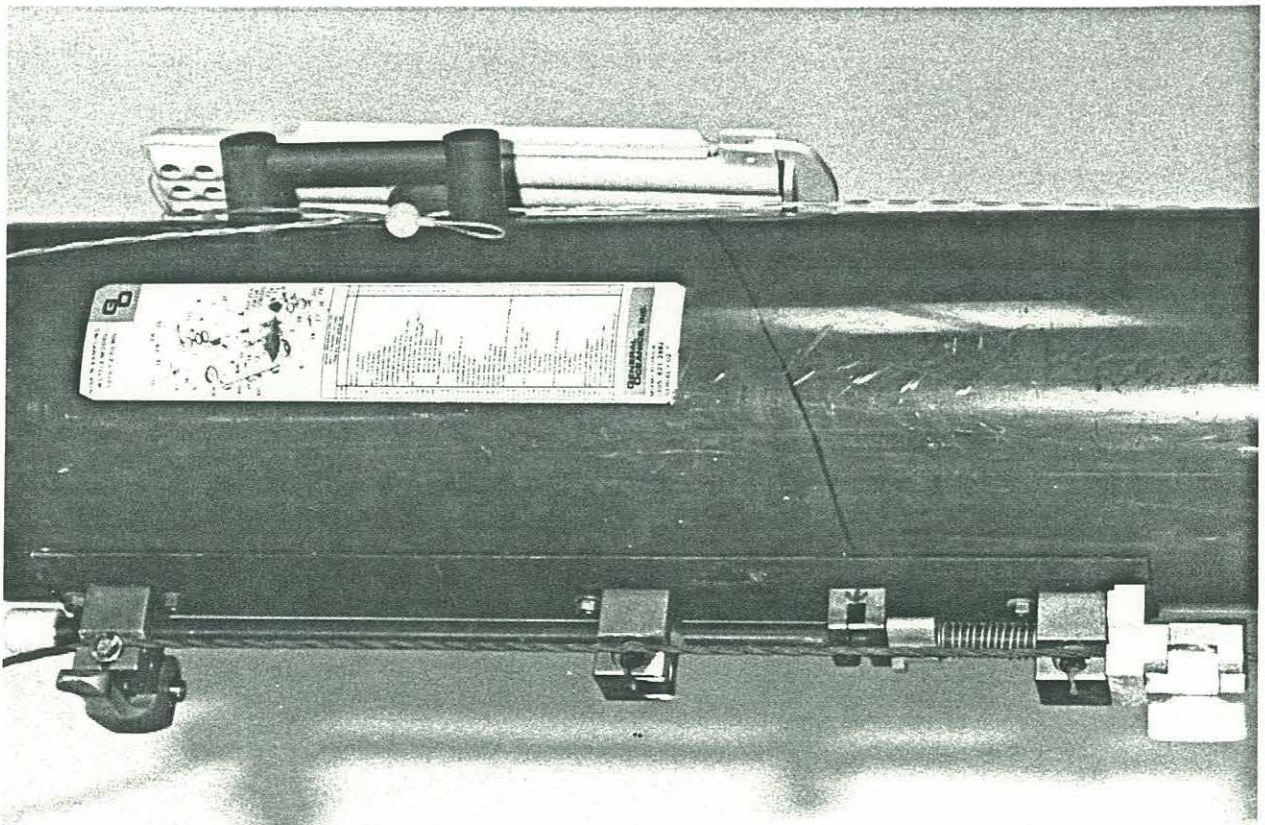

Figure 1a. Complete clamp system attached to hydrowire.

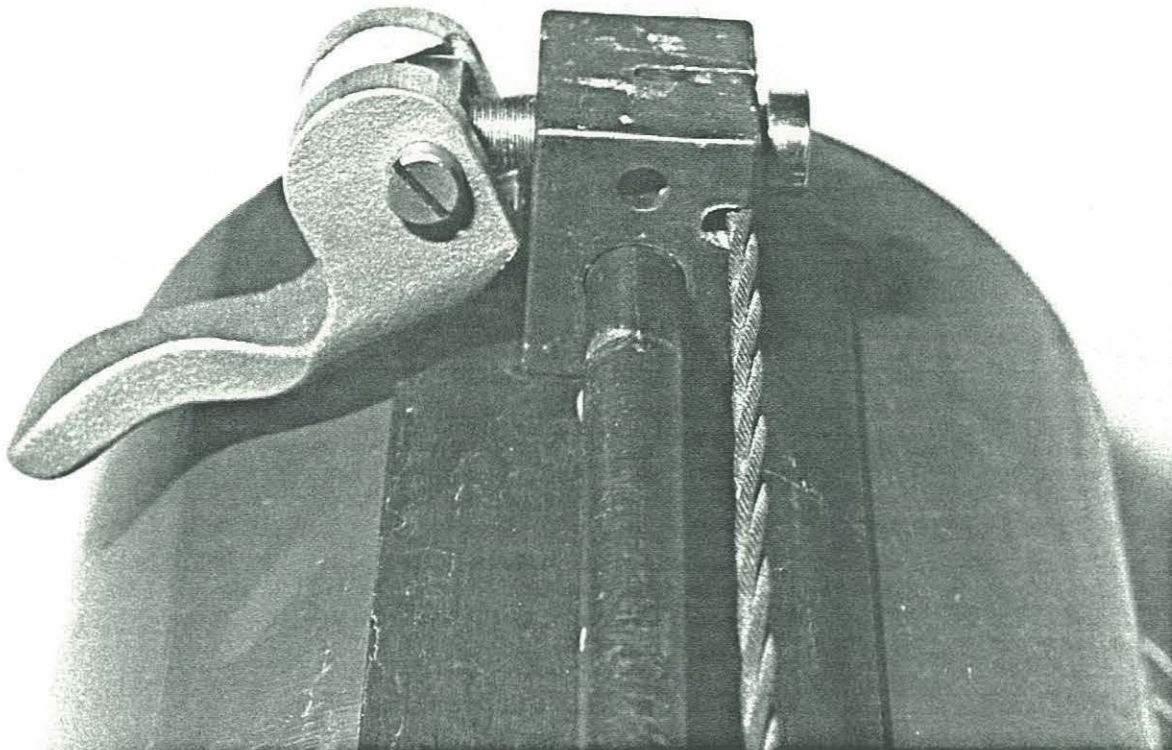

Figure 1c. Toggle clamp, open position.

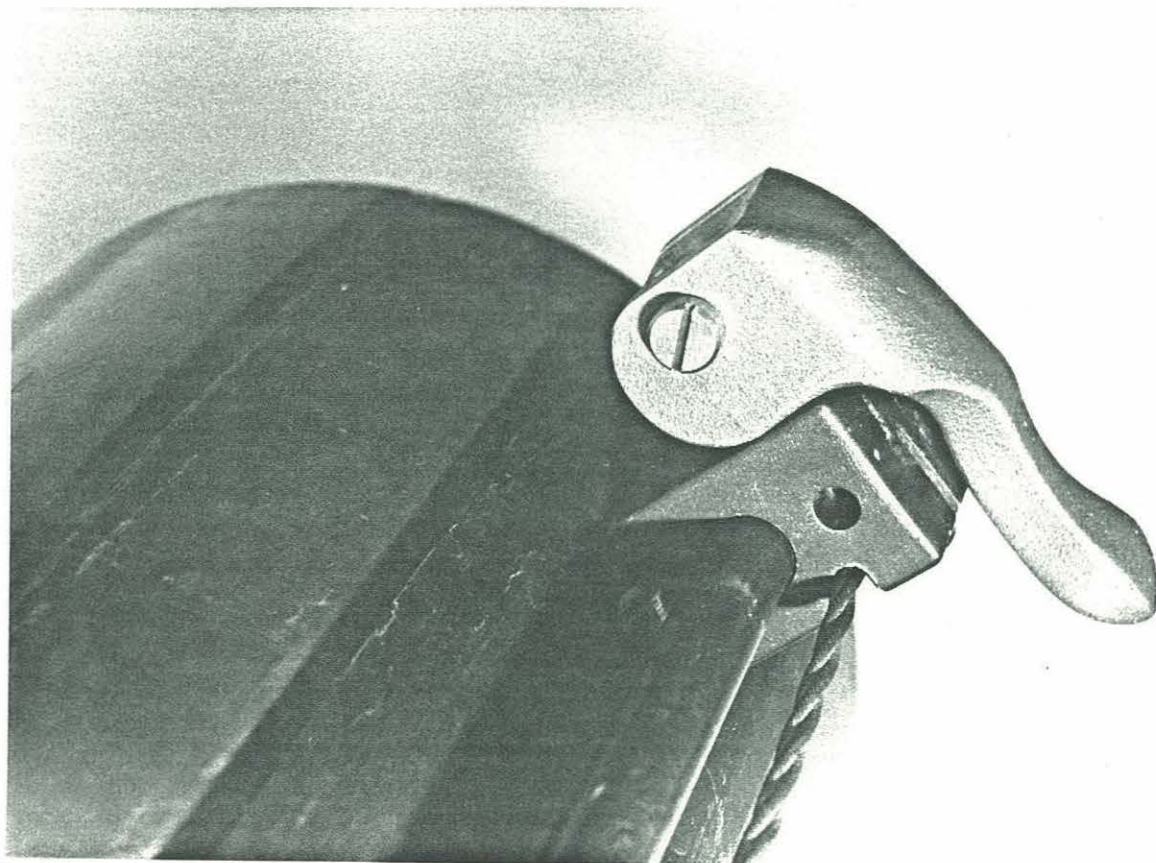

Figure 1d. Toggle clamp, closed position

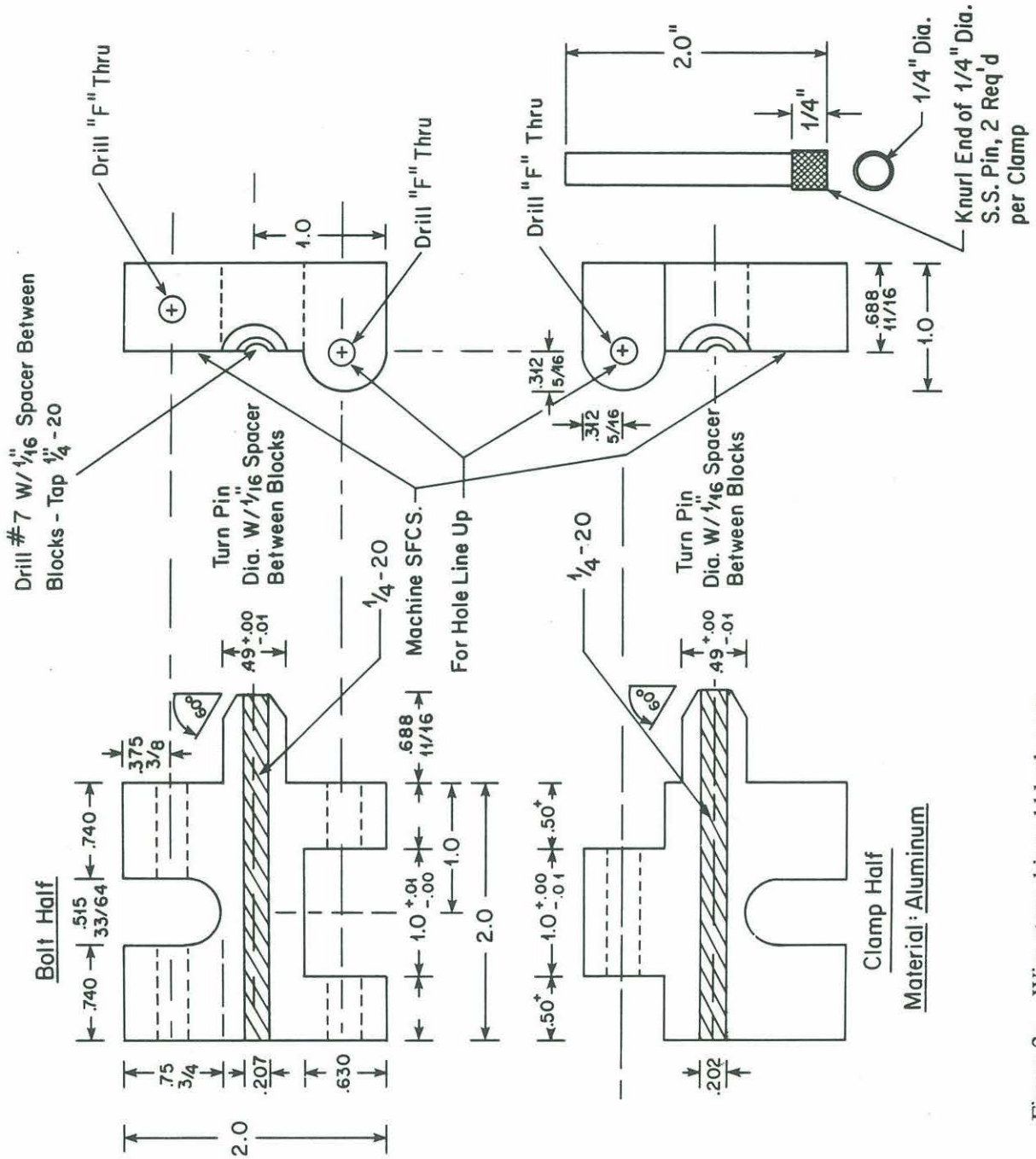

Figure 2a. Wire stop: hinged block parts.

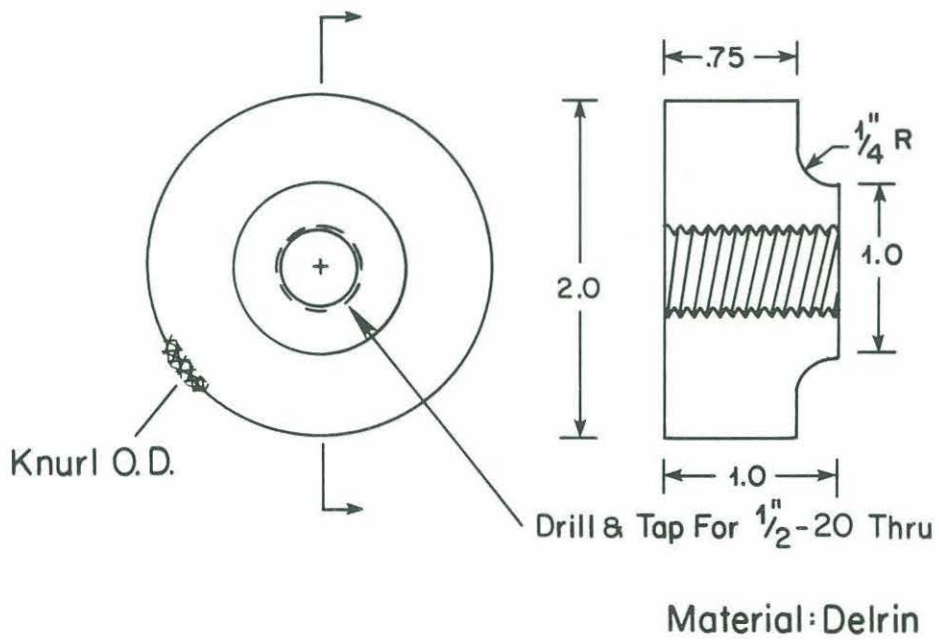
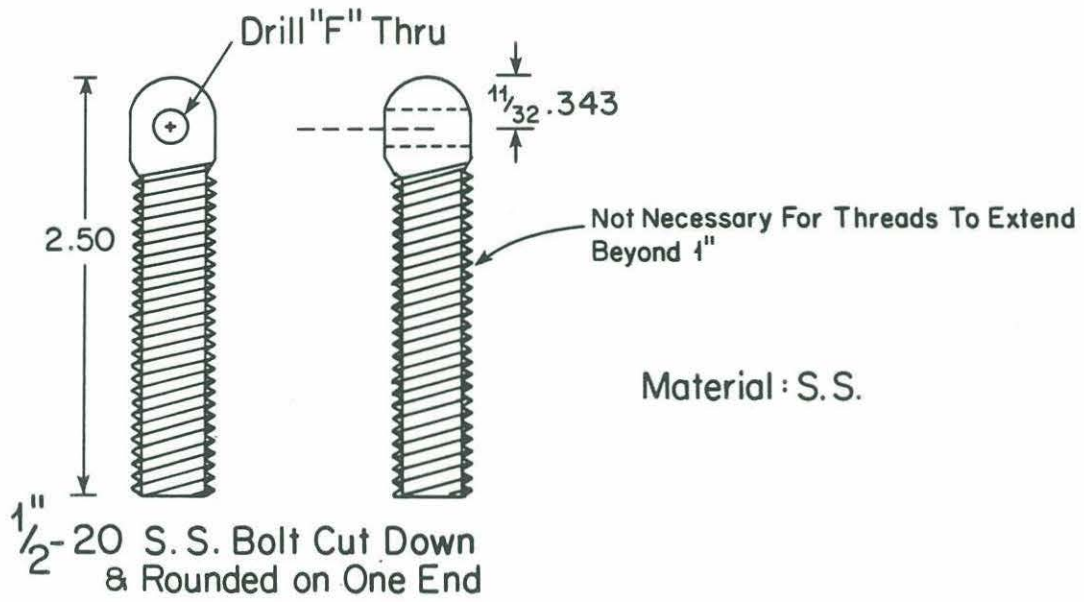

Figure 2b. Wire stop: modified bolt and delrin knob.

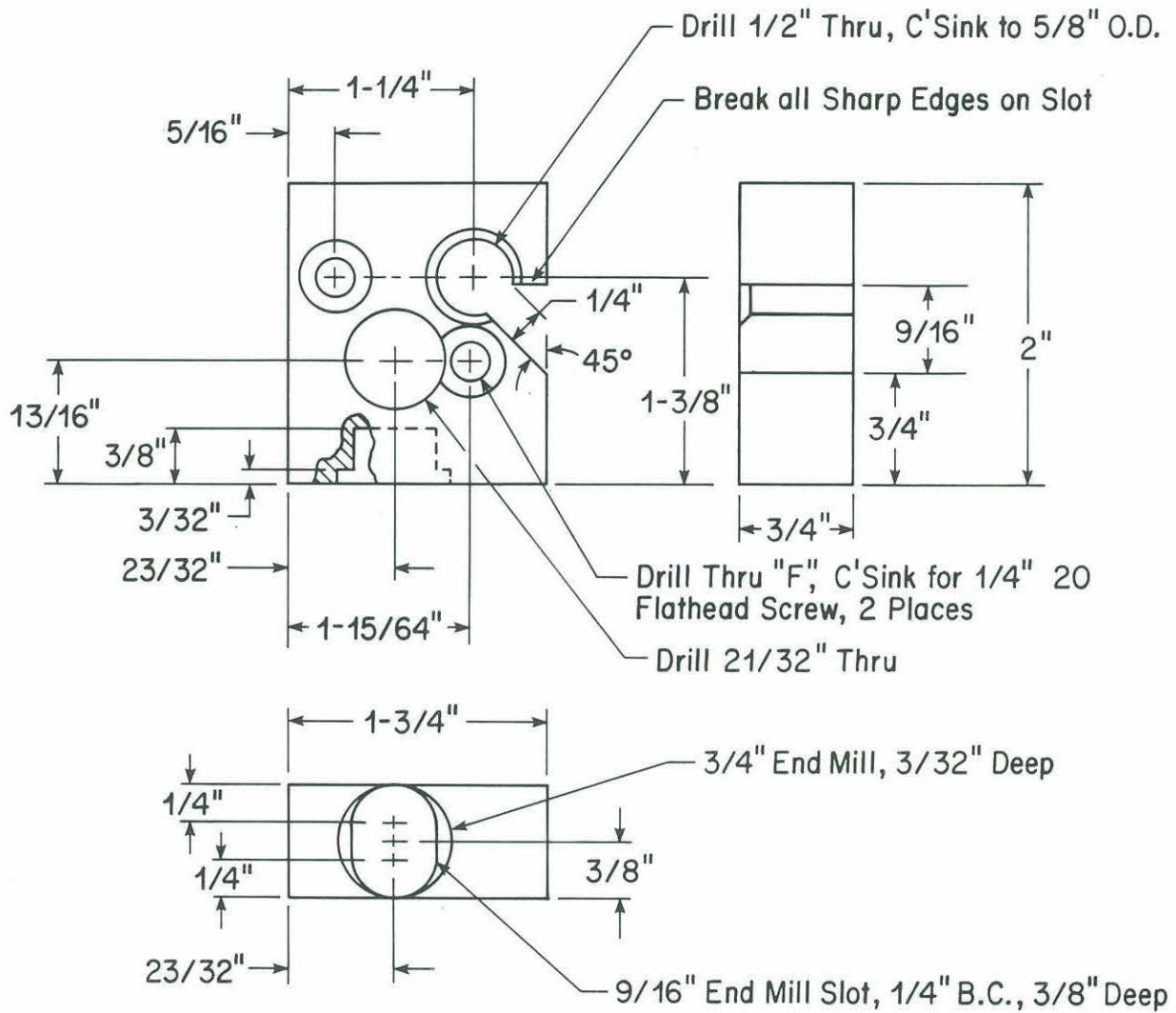

Figure 2c. Socket block.

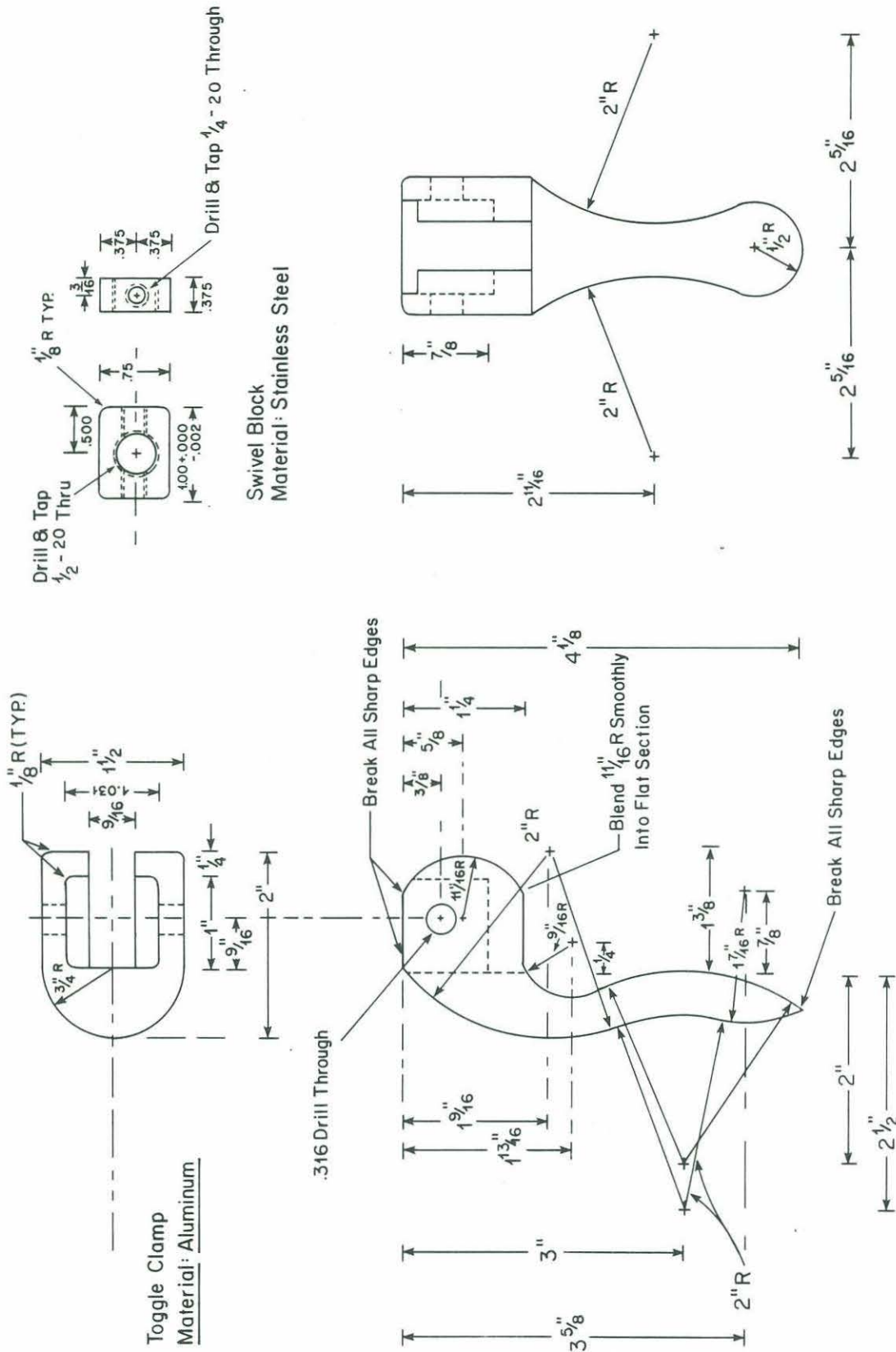

Figure 2d. Toggle clamp: handle and swivel block.

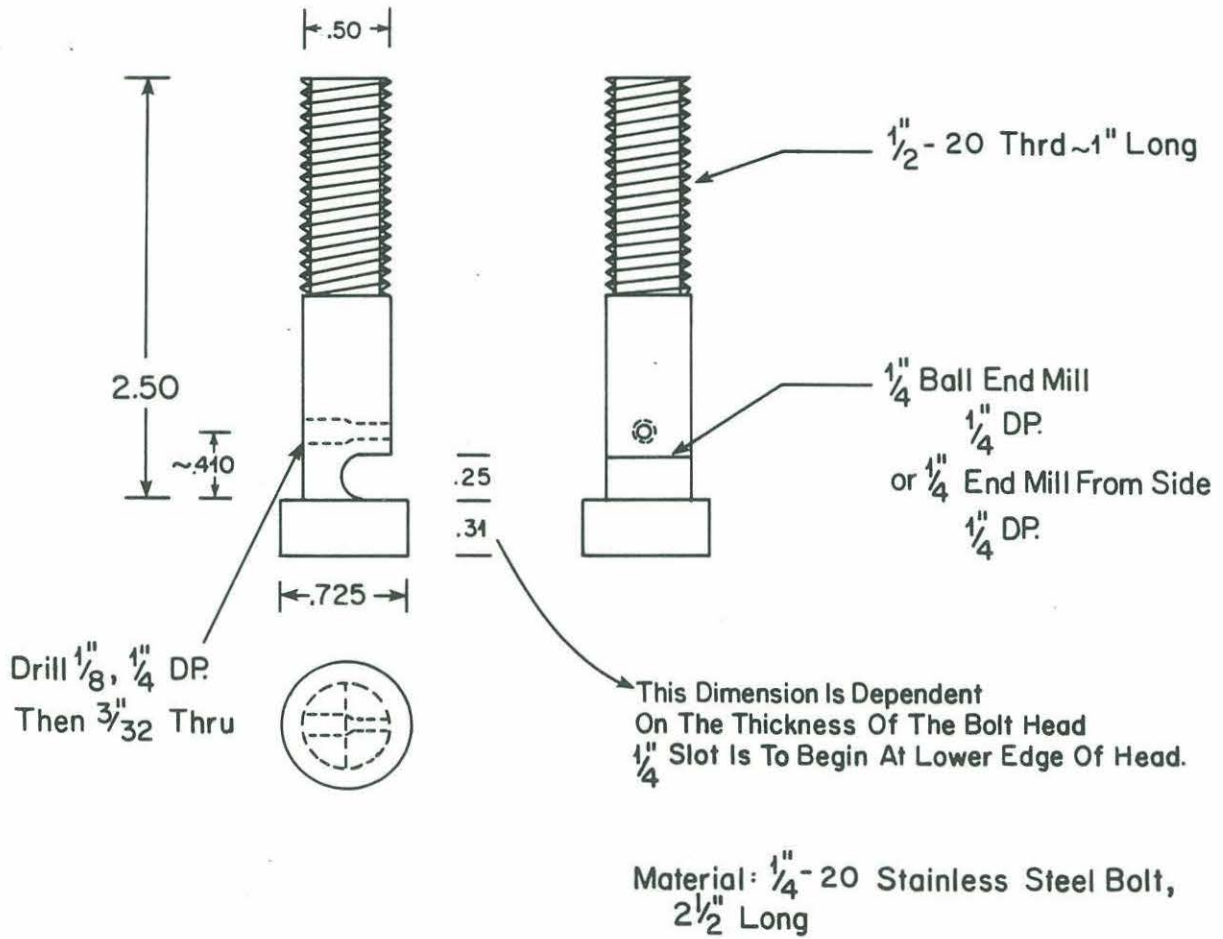

Figure 2e. Toggle clamp: modified bolt.

DOCUMENT LIBRARY

August 9, 1988

Distribution List for Technical Report Exchange

Attn: Stella Sanchez-Wade
Documents Section
Scripps Institution of Oceanography
Library, Mail Code C-075C
La Jolla, CA 92093

Hancock Library of Biology &
Oceanography
Alan Hancock Laboratory
University of Southern California
University Park
Los Angeles, CA 90089-0371

Gifts & Exchanges
Library
Bedford Institute of Oceanography
P.O. Box 1006
Dartmouth, NS, B2Y 4A2, CANADA

Office of the International
Ice Patrol
c/o Coast Guard R & D Center
Avery Point
Groton, CT 06340

Library
Physical Oceanographic Laboratory
Nova University
8000 N. Ocean Drive
Dania, FL 33304

NOAA/EDIS Miami Library Center
4301 Rickenbacker Causeway
Miami, FL 33149

Library
Skidaway Institute of Oceanography
P.O. Box 13687
Savannah, GA 31416

Institute of Geophysics
University of Hawaii
Library Room 252
2525 Correa Road
Honolulu, HI 96822

Library
Chesapeake Bay Institute
4800 Atwell Road
Shady Side, MD 20876

MIT Libraries
Serial Journal Room 14E-210
Cambridge, MA 02139

Director, Ralph M. Parsons Laboratory
Room 48-311
MIT
Cambridge, MA 02139

Marine Resources Information Center
Building E38-320
MIT
Cambridge, MA 02139

Library
Lamont-Doherty Geological
Observatory
Columbia University
Palisades, NY 10964

Library
Serials Department
Oregon State University
Corvallis, OR 97331

Pell Marine Science Library
University of Rhode Island
Narragansett Bay Campus
Narragansett, RI 02882

Working Collection
Texas A&M University
Dept. of Oceanography
College Station, TX 77843

Library
Virginia Institute of Marine Science
Gloucester Point, VA 23062

Fisheries-Oceanography Library
151 Oceanography Teaching Bldg.
University of Washington
Seattle, WA 98195

Library
R.S.M.A.S.
University of Miami
4600 Rickenbacker Causeway
Miami, FL 33149

Maury Oceanographic Library
Naval Oceanographic Office
Bay St. Louis
NSTL, MS 39522-5001

Marine Sciences Collection
Mayaguez Campus Library
University of Puerto Rico
Mayaguez, Puerto Rico 00708

REPORT DOCUMENTATION PAGE	1. REPORT NO. WHOI-88-54	2.	3. Recipient's Accession No.
Title and Subtitle Modified Wire Clamp System for Thirty-Liter Niskin Bottles		5. Report Date November 1988	
Author(s) L. Hammar, P.L. Sachs and M.P. Bacon		6.	
Performing Organization Name and Address Woods Hole Oceanographic Institution Woods Hole, Massachusetts 02543		8. Performing Organization Rept. No. WHOI-88-54	
Sponsoring Organization Name and Address National Science Foundation and the United States Department of Energy		10. Project/Task/Work Unit No.	
		11. Contract(C) or Grant(G) No. (C) DE-AC02-76EV03566 (G) OCE 84-17910	
		13. Type of Report & Period Covered Technical Report	
		14.	
Supplementary Notes This report should be cited as: Woods Hole Oceanog. Inst. Tech. Rept., WHOI-88-54.			
Abstract (Limit: 200 words) A modified clamping system for 30-liter Niskin bottles, consisting of a wire stop, a socket block, and a toggle clamp, has been designed and has been tested at sea. The modified system makes deployment and recovery of the Niskin bottles considerably easier than it is with the standard clamps.			
Document Analysis a. Descriptors sea water sampler clamp Niskin bottle			
b. Identifiers/Open-Ended Terms			
c. COSATI Field/Group			
Availability Statement Approved for publication; distribution unlimited.		19. Security Class (This Report) UNCLASSIFIED	21. No. of Pages 11
		20. Security Class (This Page)	22. Price