

Woods Hole Oceanographic Institution

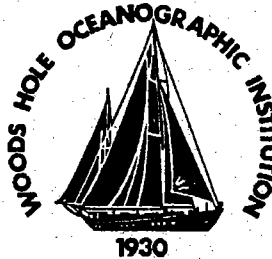

Deployment of a Bottom Monitor at a 30 Meters Deep Site in the New York Bight Apex During the Summer of 1993

by

James D. Irish

September 1993

Technical Report

Funding was provided by the National Oceanic and Atmospheric Administration and the U.S. Army Corps of Engineers, New York District.

Approved for public release; distribution unlimited.

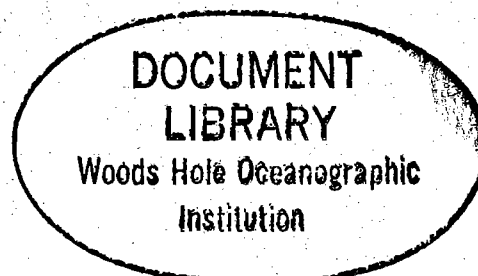

WHOI-93-43

Deployment of a Bottom Monitor at a 30 Meters Deep Site in the New York
Bight Apex During the Summer of 1993

by

James D. Irish

Woods Hole Oceanographic Institution
Woods Hole, Massachusetts 02543

September 1993

Technical Report

Funding was provided by the National Oceanic and Atmospheric Administration and the U.S.
Army Corps of Engineers, New York District.

Reproduction in whole or in part is permitted for any purpose of the United States
Government. This report should be cited as Woods Hole Oceanog. Inst. Tech. Rept.,
WHOI-93-43.

Approved for public release; distribution unlimited.

Approved for Distribution:

George V. Frisk

George V. Frisk, Chair
Applied Ocean Physics and Engineering



Deployment of a Bottom Monitor at a 30 Meters Deep Site in the New York Bight Apex during the Summer of 1993

James D. Irish
Woods Hole Oceanographic Institution

Abstract

A bottom instrument was deployed on May 5, 1993, recovered and redeployed on June 22, 1993 and finally recovered on July 28, 1993 at a 30 meter site in the New York Bight Apex. The instrument measured currents, suspended sediment concentrations, pressure, temperature and conductivity. The data storage was filled in only seven days on the first deployment and in 18 days in the second. The averaging sampling process worked well, producing hourly (first deployment) and half hourly (second deployment) values of all sensors and instrument internal diagnostics to obtain background environmental information. The burst sampling scheme sampled once a day for waves, and identified 6 and 10 second waves present. The event sampling scheme was tested for the first time. During deployment one, high frequency pressure signals were allowed to trigger events, and bad cabling caused excessive events to be recorded, filling the memory prematurely. For deployment two, only the optical sediment sensors were allowed to trigger events, and 146 events were recorded. Many of the events were only seen in one or the other optical sensor and probably associated with fish or floating debris. Other events had unique signatures, one type possibly due to passing ships.

Table of Contents

Abstract	1
List of Tables	3
List of Figures	3
1.0. Introduction	
1.1. Background	5
1.2. Bottom Instrument System	
1.2.1. Instrument Frame/Anchor	7
1.2.2. Release/Recovery System	7
1.2.3. Data System	9
1.2.4. Sensors	9
1.3. Review of Previous Tests	
1.3.1. Gulf of Maine, 1989	15
1.3.2. New York Bight, Mud Dump Site, 1989	17
1.3.3. Oyster River, 1990	17
1.3.4. WHOI Dock, 1993	17
1.4. Revisions to the instrumentation and sampling software	
1.4.1. Power System Modifications	21
1.4.2. Sampling Software Modifications	23
2.0. Field Operations in New York Bight Apex and Discussion of Results	24
2.1. Deployment One	24
2.2. Deployment Two	40
3.0. Conclusions and Future Directions	55
4.0. References	62
5.0. Acknowledgments	63
6.0. Appendices:	
A. 5 May 1993 Deployment	63
B. 22 June 1993 Turnaround	65
C. 28 July 1993 Recovery	75
D. Dredge Monitor Commands Manual	79

3. List of Tables

Table 1. Sampling Parameters for the Summer 1993 Deployments.

Table 2. Type of Sensor, Serial Number and Height off Bottom

Table 3. Power Requirements and Budget

Table 4A, B, C, D and E. Events from New York Bight Apex

4. List of Figures

Figure 1. Chart of New York Bight Apex with Mud Dump site and 1993 deployment marked.

Figure 2. The bottom instrument system as deployed in the New York Bight Apex in 1993.

Figure 3. Attenuation of bottom pressure signal in 30 meters of water as a function of frequency.

Figure 4. Wood Island Test: OBS results

Figure 5. Oyster River Test: Speed, Direction, Velocity, & Prediction.

Figure 6. Oyster River Test: Pressure, Tidal Prediction, Temperature, Salinity

Figure 7. Oyster River Test: optical sensor results

Figure 8. Hourly averages of current speed and direction, and velocity from deployment one.

Figure 9. Hourly predicted tide, bottom pressures and residual pressures from deployment one.

Figure 10. Hourly temperatures, conductivities, salinities, and OBS results from deployment one.

Figure 11. Hourly system tilts, battery and reference voltages from deployment one.

Figure 12. Summary of burst sampled pressure spectra from the six days of deployment one.

Figure 13. Event Flags for deployment one

Figure 14. Summary of the OBS event triggers and two examples of events

Figure 15. Speed Events from deployment one.

Figure 16. Averaged current speed and direction, and velocity from deployment two.

- Figure 17. Predicted tide, bottom pressures and residual pressures from deployment two.
- Figure 18. Averaged temps, conductivities, salinities, and OBS results from deployment two.
- Figure 19. Averaged tilts, battery and references voltages from deployment two.
- Figure 20. Summary of burst sampled pressure spectra from the eighteen days of deployment two
- Figure 21. Event trigger flags for deployment two.
- Figure 22. Event 4 - Single OBS signature
- Figure 23. Event 36 - Single OBS signature
- Figure 24. Event 7 - "Ship signature"
- Figure 25. Event 10 - "Ship signature"
- Figure 26. Event 28 - "Ship signature"
- Figure 27. Event 137 - High OBS signature
- Figure 28. Excess velocity in wave energy from rotor
- Figure 29. OBSs averaged, events and critical for deployment two
- Figure 30. OBSs averaged, events and a new critical with a 29 day memory
- Figure 31. OBSs averaged, events and a critical with a 3 hour memory
- Figure 32. Speed criticals from deployment two with new criteria.

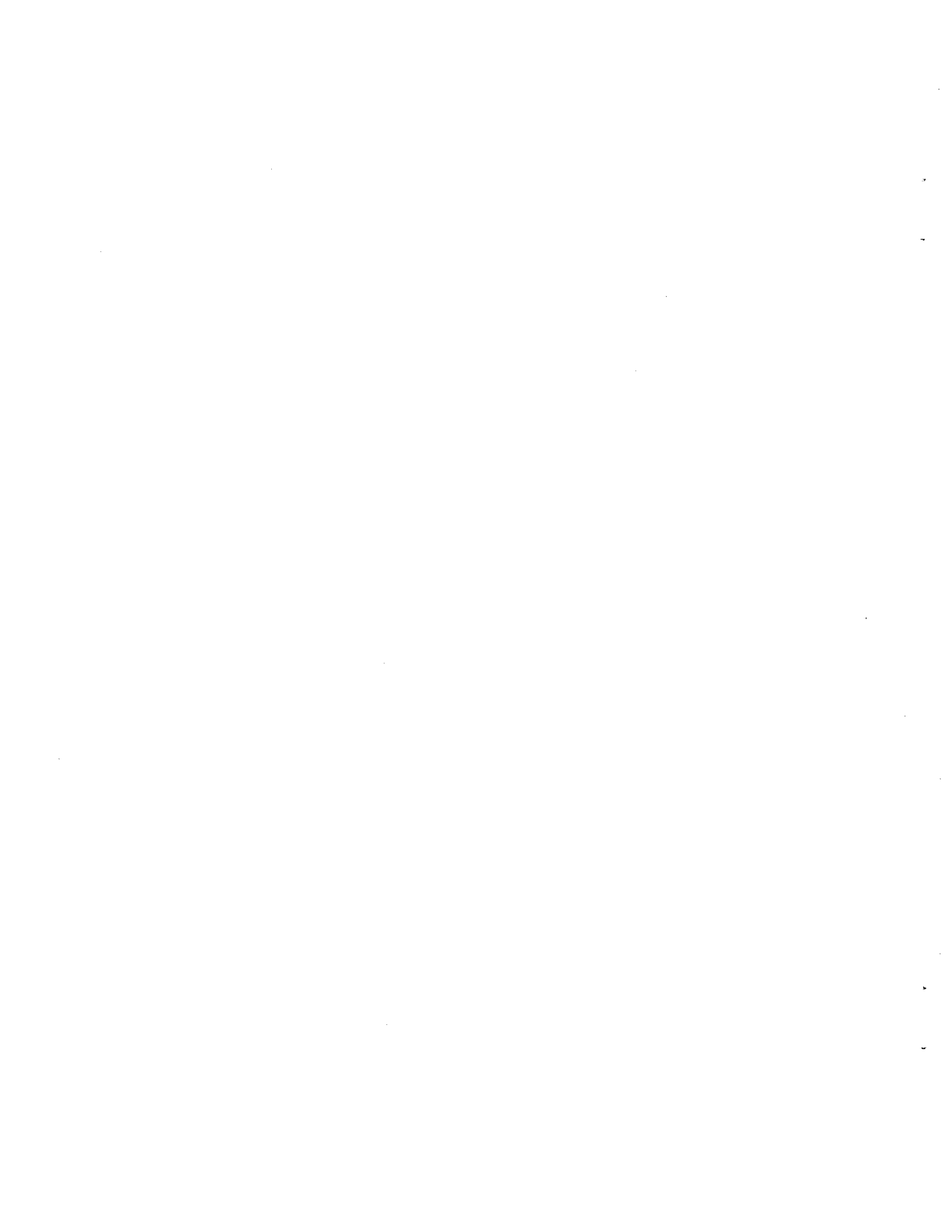

I. INTRODUCTION

1.1 Background:

Because of an increasing national pressure to understand the dynamic processes affecting resource development and management in the coastal ocean, intelligent, remote instruments are now being widely used to study the long-term variability in the environment. In response to this need, J. Irish (formerly at the University of New Hampshire and now at the Woods Hole Oceanographic Institution) and H. Bokuniewicz (at the State University of New York at Stony Brook) have been developing and testing a bottom-mounted instrument in the New York Bight as part of a US Army Corps of Engineers, New York District's program (Baldwin, Irish and Bokuniewicz, 1990; Irish, et al., 1990a, and 1990b). The main goal of this effort was to develop a remote sensing instrument capable of measuring suspended sediment concentrations around dredged material disposal sites and particularly borrow pits which are being considered as disposal sites for sediments with low levels of contamination. The instrument was developed to have long-term monitoring capability, and with conditional sampling software to allow detailed resolution of the physical conditions associated with any high suspended sediment events.

As part of this development, the prototype of a qualitative optical backscatter sensor was developed and tested (Mather, 1991). This sensor was designed as a low-cost optical sensor which did not have the stability of commercially available instruments. However, this was not considered a major problem since (1) optical sensors have considerable drift associated with biofouling, and (2) optical sensors are sensitive to the cross-sectional area of the suspended particles, so their output is a function of scattering particle area, not the particle's volume (mass). Since major corrections are necessary in order to obtain quantitative estimates of suspended sediment concentrations, additional sensor drift will introduce negligible error. The qualitative sensor resolves the higher frequency optical backscattering signal, but has greater drifts with time. If the minimum of the record is considered the baseline or clear water concentrations, then the instrument produces nearly the same signals as sensors costing about 10 times as much. These sensors were not further tested as part of the 1993 work discussed here, but have great potential in low-cost monitors (e.g. a temperature sensor, optical sediment sensor and a recorder for \$1,000) Some preliminary results are shown below in section 1.3.3.

After initial construction, the bottom instrument system was deployed in New York Bight at the Dredged Material disposal site (Figure 1) for a short test. Then the instrument was deployed in local tests in New Hampshire to gain further experience with the hardware and particularly the conditional sampling software. These tests are reviewed in section 1.3.

After these initial tests, the bottom-instrument was further refined (Irish, et al., 1991) and a simplified version deployed for one year as part of the Massachusetts Bay Program (Geyer, et al., 1993). Most recently, work was funded by the US Army Corps in the summer of 1993 to further test and demonstrate the capabilities of this instrument in the New York Bight. The site chosen (Figure 1), was in 30 meters of water at the head of the Hudson Submarine Canyon, and is of importance as a mid-shelf depth site from which to study the resuspension and cross-shelf

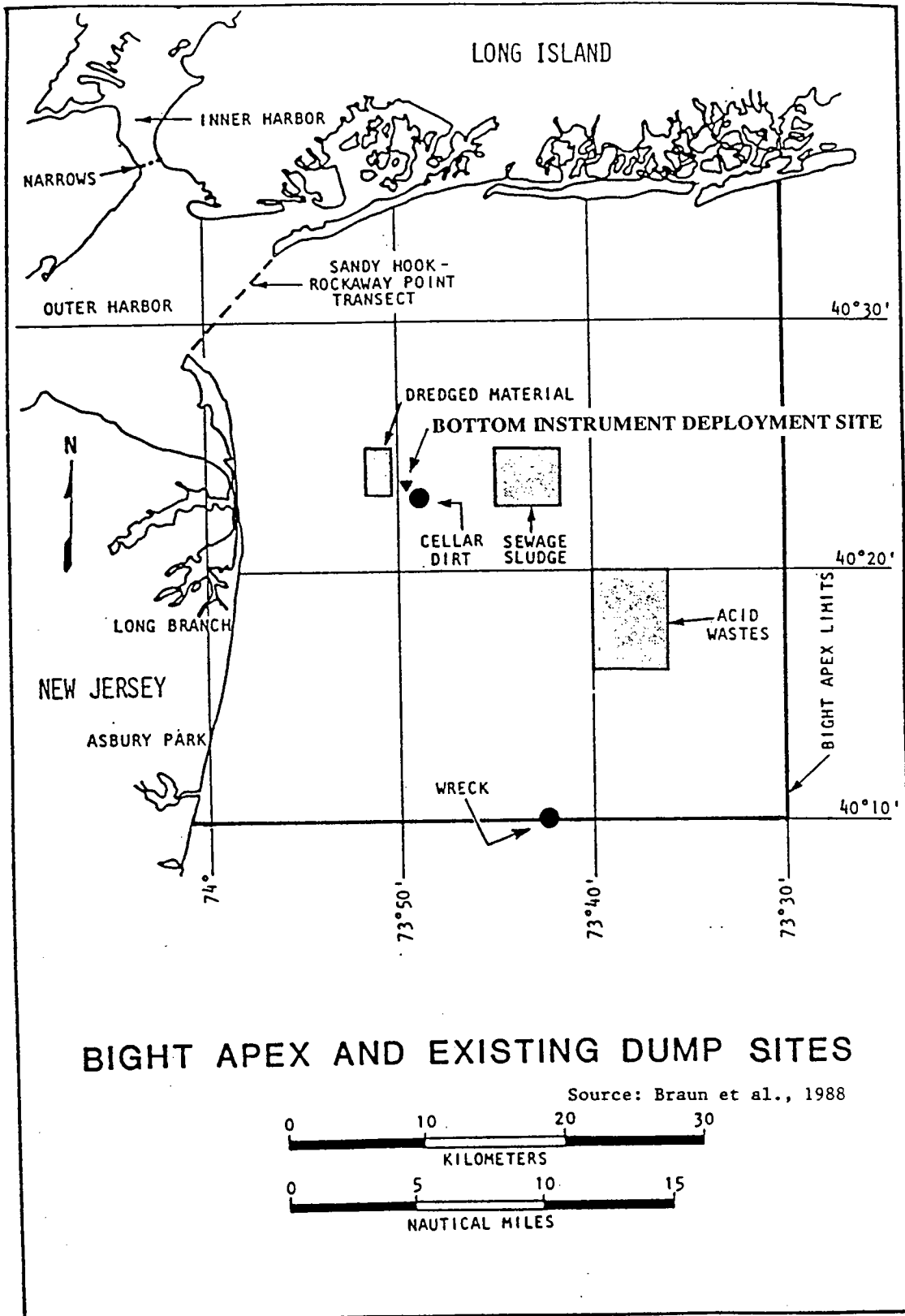

Figure 1. Chart of the New York Bight Apex. The existing US Army Corps of Engineers disposal sites are indicated, and the inverted triangle indicates the location of the summer 1993 deployment of the bottom mounted instrument system.

transport of sediment. This transport is important as it carries contaminants attached to the fine grained sediments to the deep ocean. We are proposing that this site be maintained by NOAA as part of their National Undersea Research Center in New York Bight, and we propose to participate in further long term observations of the physical processes affecting sediment suspension and transport.

1.2 Bottom Instrument System

The bottom-mounted instrument system (Figure 2) is composed of four basic components: (1) the instrument frame and anchor which act as mounts to hold the various components, (2) the release and recovery mechanism to allow instrument retrieval, (3) the intelligent data logger, and (4) the environmental sensors.

1.2.1 Instrument Frame/Anchor: To hold the instrument firmly in place on the sea floor, an anchor made of steel angle iron is used. In water it weights about 200 kg. This weight can be augmented by the addition of either railroad rail or a railroad wheel to increase the mass. An aluminum frame sits on top of the anchor, and holds the various instrument components in position. The frame has provision to mount up to 6 Benthos 43 cm diameter glass balls for flotation. This adds 150 kg of buoyancy and will float the frame, data system and sensors to the surface when separated from the anchor. For deployments in New York Bight, we did not desire to leave the anchor on the sea floor, so an alternative recovery scheme was used. The acoustic release was set to release a Benthos sphere to bring a line to the surface which is used to recover the entire instrument, including anchor. For deployment two in the summer of 1993, two glass balls were replaced on the frame to keep the centers of mass, buoyancy and drag such that the instrument will fall and sit upright on the sea floor. The aluminum frame is not anodized or painted and is insulated from the steel anchor by PVC feet and further protected from corrosion with zinc anodes. After a total of about 6 months in the water, the frame is in excellent shape, and shows no corrosion.

The sensors, acoustic release, data system, etc. are mounted on the frame. PVC, Delron, and anodized aluminum mounting hardware are used to attach the components firmly to the frame. The current meter and data system are housed in an old EG&G Model 102 current meter case attached to the center post of the frame with Delron clamps. This component has the greatest weight (25 kg in water). It is located near the center of the frame to try and keep the flow disturbance due to the frame symmetrical with direction. Stainless steel (type 316) nuts and bolts or anodized aluminum tie rods are used to bolt the components together and to the frame, and are again isolated with plastic washers from the other components.

1.2.2 Release/Recovery System: In the recent tests, the bottom instrument is recovered by a line brought to the surface by a float. An EG&G model 8201 acoustic release is mounted horizontally in the frame and holds a latch mechanism which in turn holds a 43 cm Benthos sphere in place on top of a line tub. When a release is commanded, the latch mechanism is pulled away from the sphere by three standard bungee cords (three for redundancy). The glass ball normally sits on top

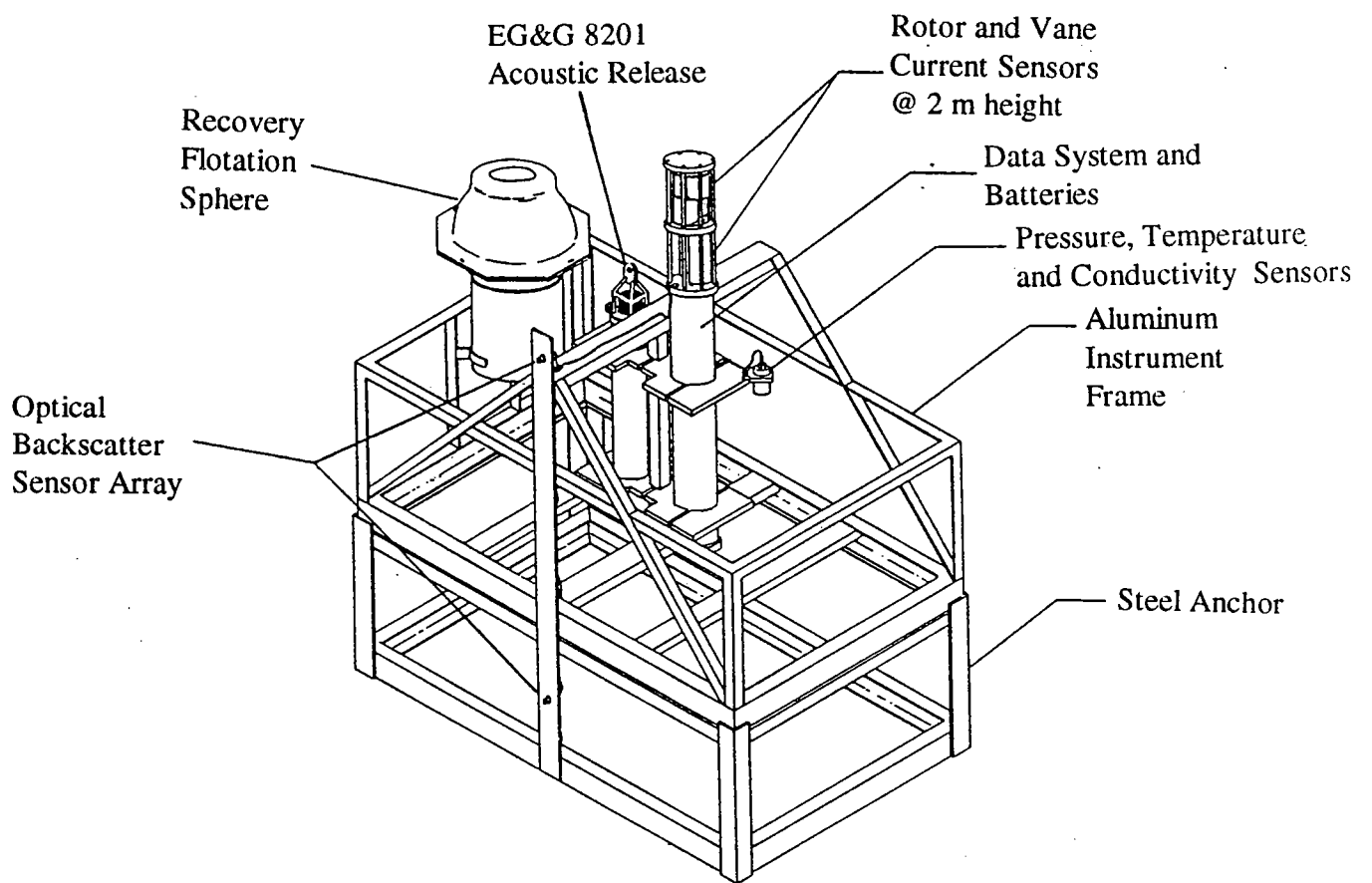

Figure 2. The bottom mounted instrument configuration as deployed in the New York Bight Apex during the summer of 1993.

of a 38 cm PVC tube which holds the line. This prevents the line from coming out and getting fouled during deployment or when the instrument is sitting on the sea floor. When the sphere is released it floats upward, pulling the line with it. The 5/8" Sampson two-in-one line is about 1.5 times the water depth, in order that there is enough extra line to bring it on board and rig for recovery. This mechanism has worked very satisfactory in more than 20 recoveries so far, with only one failure of the acoustic release itself and not the mechanical system, float or line.

The system is also designed to release the anchor and float to the surface on the additional flotation provided by up to six glass balls. The acoustic release then drops an eye bolt which holds a pin which connects the aluminum frame with the anchor. Also, another eye bolt held in place by an explosive bolt and holds the other end of the pin. Therefore, the release is a mechanical "or gate" which will drop the anchor attachment pin either by the explosive bolt through a user set timer, or by the command drop through the acoustic release. This dual release mechanism has not been used on this system because of our desire to leave the sea floor uncluttered with anchors, but has proven successful on previous systems (Snodgrass, 1968, Brown, 1976, Irish, et al., 1984). In shallow water applications, the backup release security provided by the exploding bolt and backup timer is replaced by diver retrieval.

1.2.3 Data System: The heart of the whole instrument is the microprocessor controlled data system which samples the sensors, processes the data and stores the final results. The system is based on a 8085 8 bit microprocessor which uses software control to conditionally sample the environment. This conditional sampling approach (Irish, et al., 1984; and Irish, et al., 1990a) allows the instrument to modify its sampling program based on the environmental signals that it sees. During the summer 1993 deployment, the system tested the full potential of this process by: (1) calculating averaged readings of all sensors and diagnostic parameters as initialized by the user, (2) burst sampling the pressure sensor at user selected intervals to resolve the wave field, and (3) conditionally sampling for high suspended sediment events, high current events or high wave events. The system is set up with default parameters so that if the battery is attached, the system will start sampling with the default parameters without further initialization. However, the standard way of starting an experiment is for the scientist to attach a computer or terminal to the system and set the desired sampling parameters for that experiment. For the deployments during the summer of 1993, these parameters are set as shown in the deployment logs (Appendixes A, B, and C) and summarized in Table 1.

The main limitation of the data system as it is presently configured is the capacity for data storage. The system has two 256 Kilobyte RAM boards providing 528,344 bytes of data storage. This can easily last 6 months if only the average sampling processes is used, but can be used up within 24 hours if the conditional sampling algorithms determines that an event is taking place and records the high frequency data continually.

1.2.4 Sensors: The critical interface between the environment and the data system is the sensors. Several different types are used on the instrument to record the physical parameters of interest. The type of sensor, manufacturer, model, serial number and the height off the bottom are listed in Table 2.

**TABLE 1: Sampling Parameters for
the Summer 1993 Deployment**

Parameters	WHOI Dock	NY Bight One	NY Bight Two
Date Initialized	23 April 1993	5 May 1993	22 June 1993
Sample Interval	256 samples 1/4 hour	1024 samples 1 hour	512 samples 1/2 hour
Burst Interval	4096 samples 4 hours	24,576 samples 1 day	24,576 samples 1 day
Burst Length	128 (512 pts) 7.5 minutes	128 (512 pts) 7.5 minutes	64 (256 pts) 3.75 minutes
Event Delay	2048 samples 2 hours	2048 samples 2 hours	2048 samples 2 hours
Event Limit	2048 samples 2 hours	512 samples 1/2 hour	256 samples 1/4 hour
Event Wait	2048 samples 2 hours	1024 samples 1 hour	2048 samples 2 hours
Start Time	1520 UTC	1345 UTC	1740 UTC
Event Mask X	0000 (All sensors)	0000 (All sensors)	0060 (OBSs only)
Records Saved	32,869(Full)	33,381(Full)	29,971 (Full)
Averaged Samples	273	156	885
Burst Samples	8,704	3,072	4,608
Event Samples	10,139	10,818	9,311

* Basic Sampling interval is 3.515625 seconds - 1 hr/1024

TABLE 2: Sensor - Type, Model, Serial Number & Height off Bottom

Sensor	Manufacturer/Model	Serial Number	Height off Bottom (m) *
Current Speed and Direction	EG&G 102 with WHOI bearings & Data System	GERDA	2.21 2.00
Compass	Aanderaa/1248	16339	1.27
Temperature 1	Sea Data/Thermistor	323	1.85
Temperature 2	Sea Bird/SBE-3	490	1.57
Conductivity	Sea Bird/SBE-4	70	1.57
Pressure 1	Paroscientific	569	0.74
Pressure 2	Druck/PDCR920	553421	0.75
Optical 1	D&A Inst. Co./OBS-1	147	0.11
Optical 2	D&A Inst. Co./OBS-1	145	1.01
Tilt 1	Schaevitz/AccuStar	91560174	1.35
Tilt 2	Schaevitz/AccuStar	91560175	1.35

* Heights are measured from deck of R/V ONRUST.
Instrument will settle into the bottom slightly.

Currents: The currents are measured by the Savonius rotor and vane from an EG&G Model 102 current meter. The speed of the water is measured by a Savonius rotor, the current's direction relative to the bottom frame is measured by the vane, and the orientation of the frame relative to magnetic north is measured by an Aanderaa compass. New bearings for the Savonius rotor and vane were added as suggested by WHOI for their VACM current meters. The software sampling program reads the number of rotor revolutions, the vane and compass heading at the basic rate of once every 3.5156 seconds (1 hour /1024) and calculates the eastgoing and northgoing velocity vectors which it then averages over the programmed sample interval. The speed is averaged over the 3.5156 second sample interval while the compass and vane are analog voltages which are digitized at the end of the 3.5156 second interval. In addition to the vector averages, the instrument also records the rotor count. The difference between the rotor speed and the speed calculated from the vector averages of velocity allow one to estimate of the wave velocity which is averaged out during the vector averaging process, but not from the direct speed (rotor) measurement and is important in suspending sediment.

The compass and vane follower are both Aanderaa compasses. These are not the newest in technology (i.e. flux-gate) but they appear to work well and give consistent results to within a degree or two. There is the potential or error from the metal in the battery pack located near the compass, and the iron instrument anchor, located about 1 meter away from the compass. It is not clear what errors exist, but in a bottom mounted instrument, the error in compass reading creates a constant error in current direction which can be corrected for by a simple rotation. With a current meter on a mooring where the instrument case rotates, this is not the case and generally corrections for directional errors due to compass errors can not be made.

Temperature: Two temperature measurements are made in the bottom instrument. A thermistor in the current meter's end cap measures temperature to $\pm 0.02^{\circ}\text{C}$. This measurement is an average over the sample interval, and has the time constant of the thermal mass of the pressure case (about 2 minutes, Levine, 1981). The other temperature sensor is a Sea Bird SBE-3 thermometer which measures temperature to $\pm 0.001^{\circ}\text{C}$, and has a response time of about 800 ms. This sensor is mounted on the frame where it is exposed to free flushing while still protected from physical damage. It is mounted beside the conductivity sensor and used to calculate salinity. Both temperature sensors are frequency modulated devices whose frequencies are counted over the sample interval and this counting process averages the value and prevents aliasing.

Salinity: Salinity is not directly measured, but calculated from temperature and conductivity. Conductivity is measured with a Sea Bird SBE-4 conductivity sensor, to about ± 0.001 S/m. A major limitation to conductivity measurements is the contamination of the cell by biofouling and sediment. Trialkyltin antifouling tubes are used on the conductivity cell to reduce biofouling for up to 6 months. By mounting the conductivity sensor at an angle, it is hoped that sediments will not settle and remain in the cell effecting the measurement. Both these factors cause lower conductivity than expected, and should be a main limitation to good, long term moored measurements of salinity in the coastal ocean. The Sea Bird conductivity sensor is a frequency modulated device whose frequency is also counted (and thus averaged) over the sample interval.

Pressure: Two pressure sensors are used for the pressure measurement. The primary sensor is a Paroscientific pressure sensor which uses a quartz crystal to convert pressure to a frequency which can be counted. This sensor is expensive, but the state of technology today. Its output is a frequency which is counted (and thus averaged) over the sample interval. The other pressure sensor is a Druck strain gauge with its own electronics (designed and constructed at WHOI). This outputs a voltage which is digitized every 3.5156 seconds and averaged. The sample is taken over a 10 ms interval, and this is a point reading, and subject to potential aliasing. However, the high frequency pressure fluctuations are due to surface waves which are attenuated with depth which reduces the signal as a function of frequency and thus reduces the potential for aliasing. Figure 3 shows the attenuation of the pressure amplitude with frequency for a pressure sensor on the bottom in 30 meters of water. At the Nyquist frequency for the 3.5156 second samples (0.1422 Hz) the signal is attenuated by 8 db (or the signal is 0.4 times the signal at the surface). Thus, most of the lower frequency waves (6 to 20 second periods) penetrate to the sea floor and should be measured by the 3.5156 second event sampling with little aliasing.

The Druck pressure sensor is also burst sampled at a higher rate of 0.8789 seconds or 4 samples per 3.515625 seconds. At the Nyquist frequency for this sample rate (0.57 Hz), the depth attenuates the signal to greater than 100 db. This sampling rate was selected for work in shallower water with less attenuation, and is oversampled for this depth. At 30 meters, half the rate (1.75 seconds) would be adequate to sample the signal that reaches the bottom. A higher rate of sampling is not warranted, and the burst samples should resolve the full spectrum of pressure signals which reach the sea floor.

Optical Backscattering Sensors: The sensor used to measure the amount of suspended sediment in the water is the Downing and Associates OBS-1 (Optical Backscattering Sensor). This sensor has become a standard for high suspended sediment concentrations and is used here instead of a beam transmissometer. Although the instrument has the capability of sampling four OBS sensors, only two were deployed in this test. The output of these sensors is an analog voltage which is digitized every 3.515625 seconds. These sensors were mounted on the side of the instrument frame looking out into the water column away from the frame. The optical path of these sensors are oriented horizontal so they see the sediments at the same depth along the beam. With the low concentrations seen during the summer of 1993 deployments, the beam extends out as far as 20 cm, so the measurement is actually over a relatively small volume of water.

Tilts: As a diagnostic of instrument orientation, two Schaevitz AccuStar tilt sensors were installed near the compass to measure the current meter tilt. These sensors are powered continually, but only sampled every 3.5156 seconds. The sensors generally drift during an experiment by a fraction of a degree, but so far never more than 1 degree. Their accuracy decreases significantly after 45°. On the continental shelf, tilts of up to 10° are typical, and generally they are smaller. This correction is only important when the current meter is used in a mooring in high current regions.

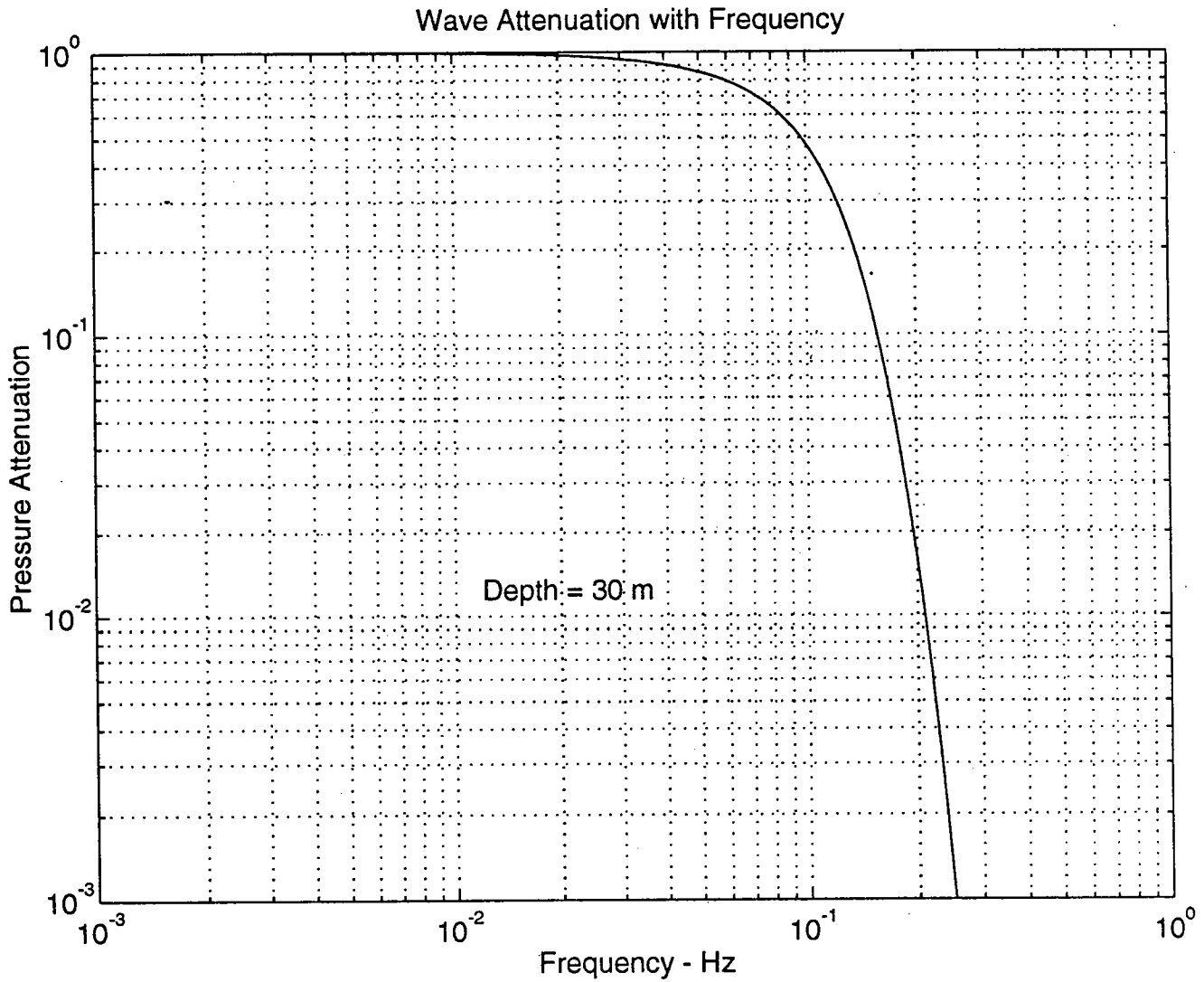

Figure 3. The attenuation of pressure on the bottom in 30 meters of water as a function of frequency. The waves are moderately attenuated at the basic sampling rate of 3.5156 seconds, but are attenuated greater than 100 db at the Nyquist of the 0.8789 second sampled bursts. This should be used to correct the pressure spectra to predict surface wave heights.

Other Diagnostics: The instrument records two voltages as diagnostics. The switched, regulated voltage for the vane and compass is about 4.88v and the reference voltage is measured so that the sensor's output is then the ratio of their reading to the reference voltage. Also the system battery voltage is recorded to show if the power consumed is as predicted, and to show if there should be any sensor problems due to low voltage.

1.3 Review of Previous Tests

1.3.1. Gulf of Maine Tests: The first tests of the instrument were held in the Piscataqua River between New Hampshire and Maine. The instrument was deployed at the NH State Fish Pier to see if things would work at all, and if any data were recorded. The instrument was attached by a wire into a monitoring computer so that the data could be watched while the instrument was lowered and sitting on the bottom in 3 meters of water. The rotor and vane were not unblocked, but everything else worked properly. After further analysis, minor problems were uncovered and repaired dealing with the packing and unpacking of the data from storage.

Then, the instrument was deployed in 19 meters of water off Wood Island in the Piscataqua River for three hours. During that time, the instrument's performance was monitored by a packet radio link between a surface buoy hardwired to the bottom instrument and the R/V JERE CHASE anchored nearby. The instrument was tipped over on its side during these tests by the drag on the surface spar buoy. The current at the bottom was about 1 knot when this happened, so it is not a normal occurrence. Otherwise the system appeared to work well, except that when an event was determined, the instrument sent a signal out through the packet radio link, and managed to back up the link with messages so that it became inoperative. Changes were made in the software so that the system would only transmit data when the event trigger changed states, to reduce the amount of data that needs to be transmitted. One of the four OBS sensors did not work (at 183 cm), but the other three returned good signals with the one at 15 cm showing the greatest signal, then the one at 46 cm and the one at 91 cm the least (Figure 4). The 15 cm OBS sensor also shows a sharp spike which occurred at the time that the current drag on the spar buoy of the packet radio link tipped over the instrument frame. The data from this test showed that the basic instrument was working and ready for testing in coastal waters.

The final test before being deployed in New York Bight was near the Isle of Shoals offshore of Portsmouth, NH. The instrument was deployed in 25 meters of water at 42° 59' 12.1" N x 70° 39' 15.3" W 7.5 nm SE of Portsmouth, NH on 6 Sept. 1989. The system worked well, but had the same problem with getting too many commands backed up in the packet radio link so that it took a long time to transmit data to and from the bottom instrument. The real benefit of the packet radio was seen during these tests as the operation of the instrument could be checked as it was in place on the sea floor, and if patient, changes could be made and checked out without recovering the instrument. Currents were about 10 to 15 cm/sec, typical of shelf conditions, and the spar buoy of packet radio did not have problems with high currents. Some indication of problems with the cabling to the Sea Bird temperature sensor were seen, although the conductivity appeared to be operating properly. Again the OBS sensor at 183 cm did not

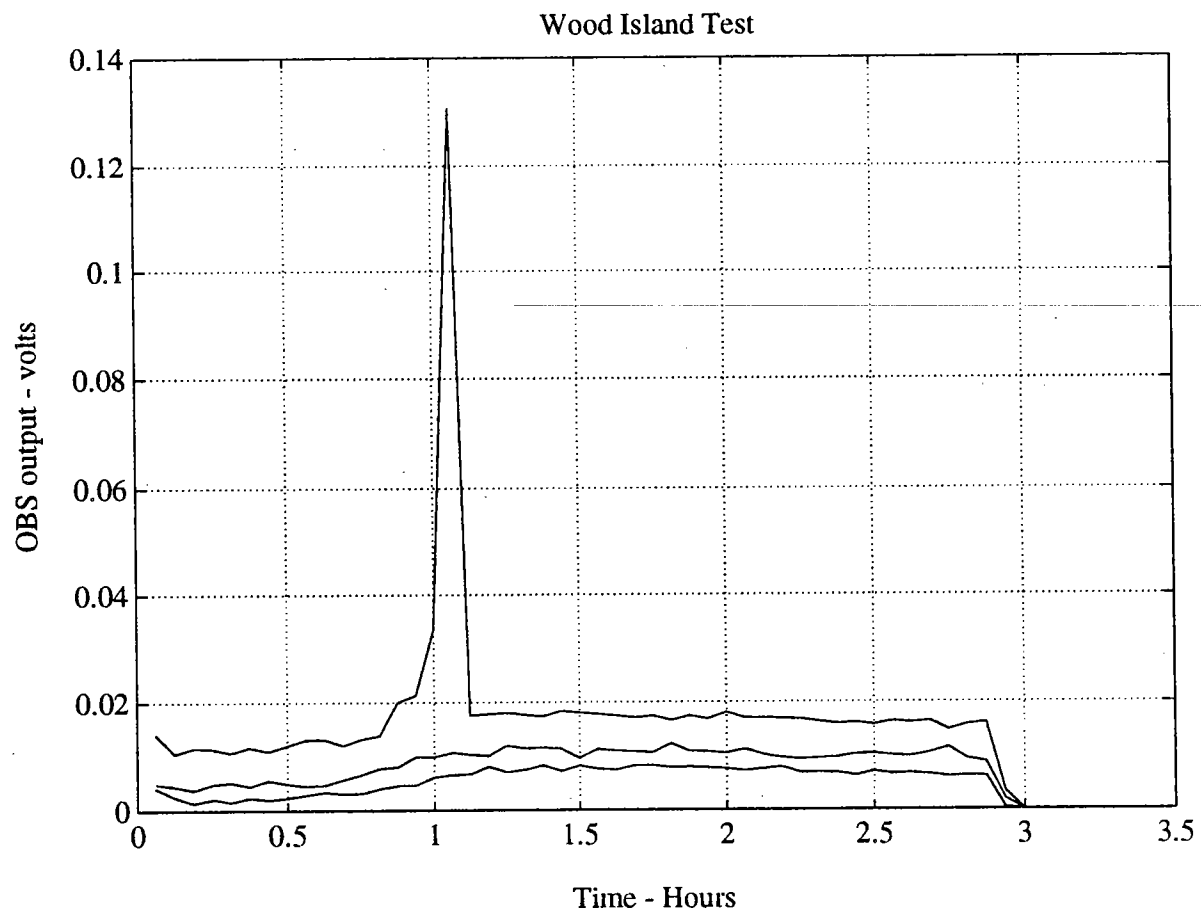

Figure 4. Wood Island Tests. The first deployment of the bottom instrument was at Wood Island in the Piscataqua river near Portsmouth, NH. The of optical backscattering at 15, 46 and 91 cm, are shown with the signals increasing as the bottom is approached.

function while, the ones at 15, 46 and 91 cm appeared to give good signals with the lowest backscattering energy found highest in the water column, and the larger signals near the bottom. The signals were not large, showing no real suspension events. During the few hours of this test, the system and sensors were powered continually, and the battery was observed to lose 1/5 of their capacity. Therefore, the full system with four OBS sensors and telemetry is only capable of being used continually over a 1 day period. This severely limits the long term usage of the instrument, but allowed these first order tests to be accomplished.

1.3.2. New York Bight / Corps Mud Dump Site: The first real test of the system took place in the fall of 1989 at the Dredged Material disposal site in New York Bight (Figure 1). The instrument was deployed while the R/V ONRUST of SUNY/ Stony Brook stood by. The several hour deployment did not record any "events" from the two dumping events that took place at the Mud Dump Site while the instrument was on the bottom. Experience was gained with the sampling algorithm and hardware. The results of this test are summarized in Irish, et al., 1990a and the hardware discussed in Irish, et al., 1990b.

1.3.3. Oyster River: After the first tests in New York Bight, the sampling software was further refined, the packet radio link removed, and more tests made as part of the UNH qualitative, optical sensor development. On 17 Sept. 1990, a deployment was made at the mouth of the Oyster river in the Piscataqua River. The instrument was deployed for three full days, and recovered on 20 Sept. 1990. The principle signal seen was tidal, with strong tidal currents (Figure 5) which were very well predicted (Figure 5d) by tidal analysis of NOS instruments deployed up the river at the Jackson Estuarine Laboratory just over 1 nm distant (Swift and Brown, 1983). The tidal height from nearby Dover Point, agreed very well with the pressure sensor observations (Figure 6a). The temperature sensors showed two degree tidal oscillations superimposed on a steady fall cooling (Figure 6b) and the thermistor end cap sensor and Sea Bird sensor agreed. The salinity record (Figure 6d) did not have the trend seen in temperature, but had 2 PSU variations at tidal frequency. The optical sensors also showed tidal variations, with sharp spikes superimposed (Figure 7). Since the deployment was in the fall and leaves were visible floating in the water, these spikes are attributed to these signals, and not sensor problems. There are changes in suspended sediment concentrations coherent with the tides, but no large suspended sediment events other than the spikes, were seen. A comparison with of two OBS sensors with UNH optical sensors mounted at the same depths (15 cm and 46 cm), showed good agreement during the three days (Figure 7a and 7b), confirming that these low cost sensors would make viable monitoring instruments.

1.3.4. WHOI Dock: In preparation for the 1993 deployment in the New York Bight Apex, modifications were made to the instrument as discussed below, and a deployment made in the well in the WHOI dock over the weekend of 23-26 April 1990. The instrument was not mounted in its frame, but the sensors were all mounted to the current meter and this package hung off the dock at about 3 meters below the surface. Typical tidal currents of 25 cm/sec were seen, 0.5 m pressure variations due to the tides corresponded with the velocity records. The Sea Bird temperature and conductivity sensors showed noisy records which were traced to a bad splice in the underwater connector cabling which was respliced before the deployment in New York Bight.

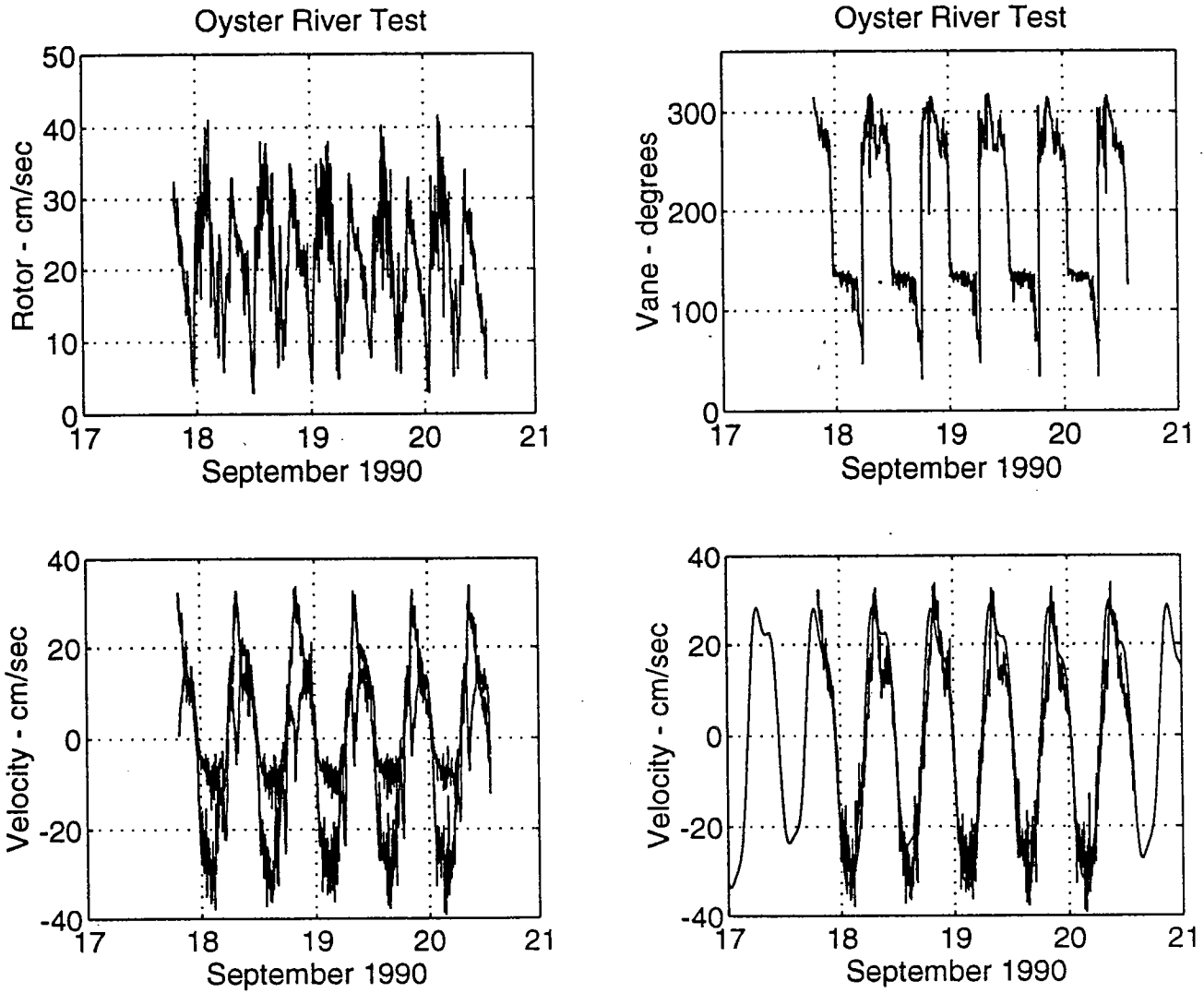

Figure 5. Oyster River Test Velocities. The Savonius rotor record of speed (a) is typically tidal. The direction (b) shows the in and out or bidirectional nature of the currents vectors (c). The along channel (North-South component) is well predicted from previous measurements (d).

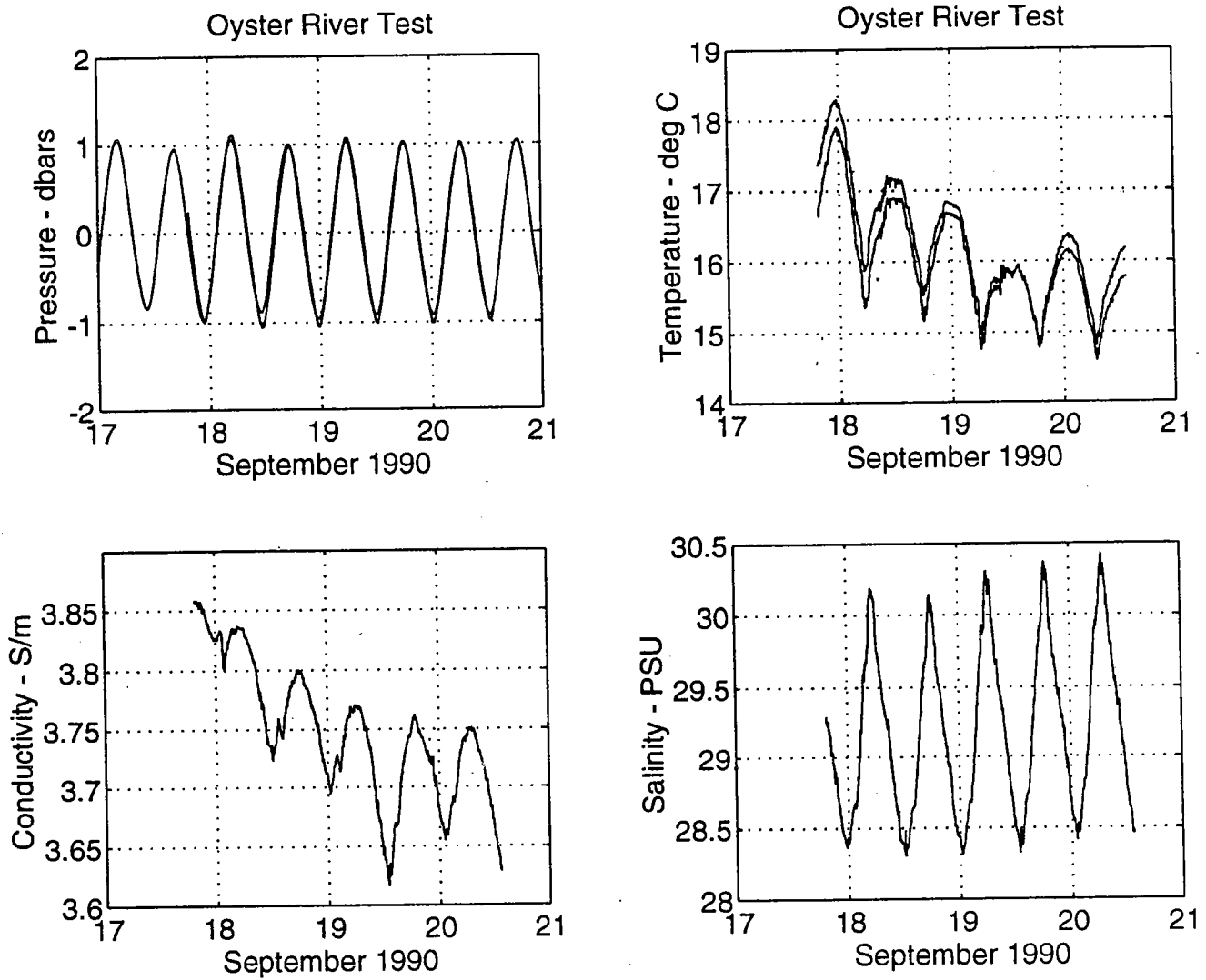

Figure 6. Oyster River Test Physical Properties. The Paroscientific pressure record (a) agrees well with prediction from previous measurements. The Sea Bird and end cap measurements of temperature (b) are tidal and show the fall cooling. The Sea Bird conductivity record (c) looks similar to temperature, but the calculated salinity (d) does not have the trend, but shows large (2 PSU) changes in salinity with the tide.

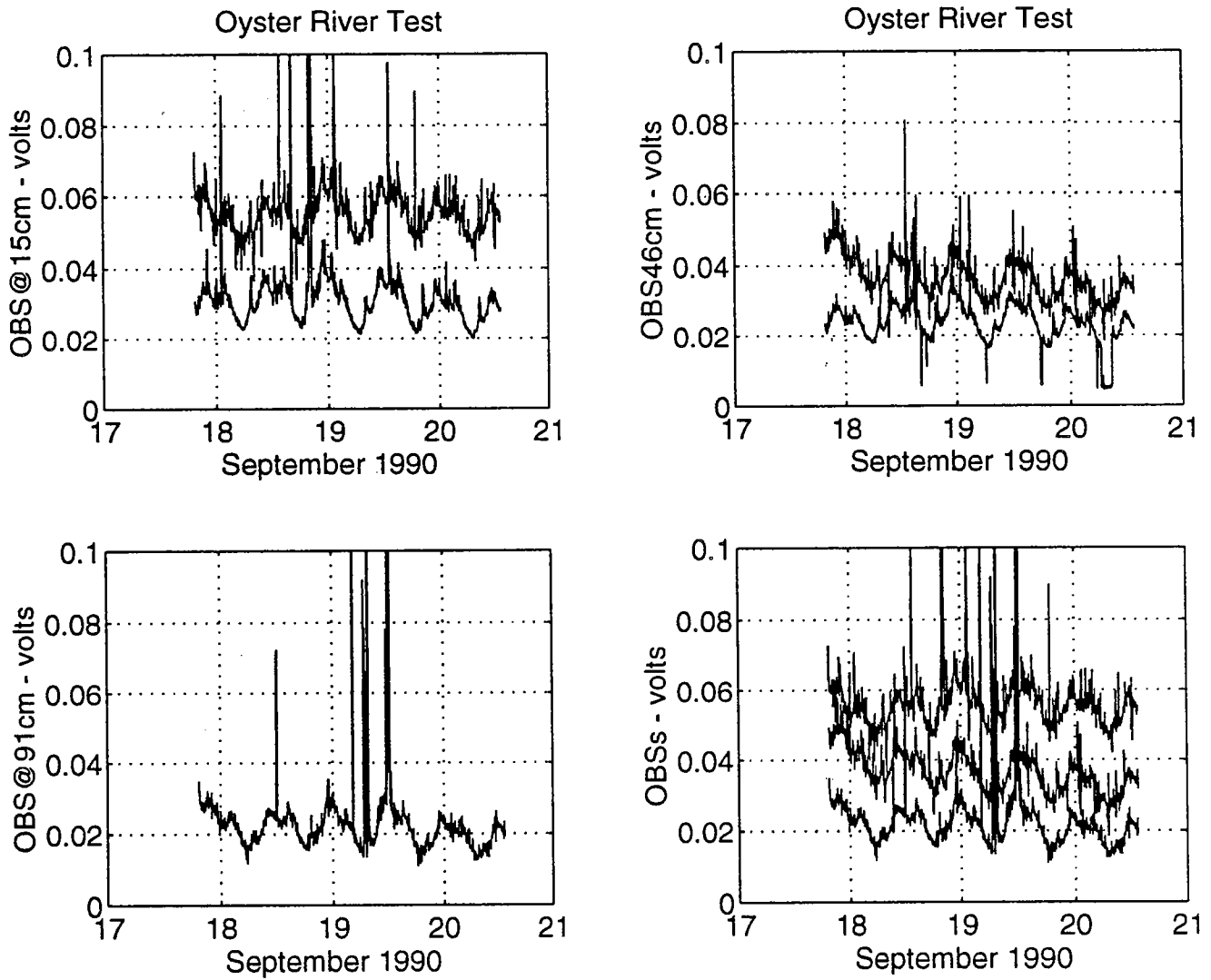

Figure 7. Oyster River Test optical sensors. The top two plots compare the OBS sensors (upper curves) with the UNH qualitative sensors (lower curves). Panel (a) shows the comparison at 15 cm above the bottom, Panel (b) at 46 cm, and Panel (c) the OBS at 91 cm. The three OBS sensors are summarized in (d) with the signal increasing toward the bed.

The OBS sensors showed some very large signals in one sensor, which may be related to mechanical blocking of the sensor by kelp. The tilt sensors showed a 5° tilt with $\pm 5^\circ$ changes in tilt associated with the tidal currents. The instrument recorded bursts and events, filling the memory over the weekend. This indicates that there may have to be changes in the definition of events to prevent the memory from being filled by too many unimportant events.

1.4 Revisions to the Instrument and Sampling Software

1.4.1. Power System Modifications: The power requirements for the instrument system as deployed during the summer of 1993 are given in Table 3. The two OBS sensors draw about 60 ma each, and are the major power sink in the instrument system. To extend the deployment time beyond a day or two, the power to these sensors was cycled with a 14% duty cycle. This implies that the sensors are turned on long enough before the A/D samples them that they have stabilized. Unfortunately, the model OBS-1 sensors require 10 seconds to really stabilize once they have been powered up. (Note: the newer model OBS-3 sensors, using a different circuit board, require only 15 ma of power, and will stabilize in less than 1 second and therefore are better matched to our instrument's sampling scheme when used in long deployments with the power switched.) It was decided that we could not wait 10 seconds for the sensor to warm up, or there would be no power saving, and the option of turning the sensors on once per hour for a burst did not seem reasonable because of the high probability of aliasing and we would miss the short events discussed below. Besides having their power switched, the two OBS sensors were wired so that the clock of the first drove the timing of the second. Therefore, only one LED is on at a time, and with two sensors, the power drain on the batteries is not as "spiky" and should improve battery life. A FET switch, controlled by the microprocessor, switches the power to the sensors on for about 0.5 seconds before the sample and shuts the power off after the A/D has completed taking the last reading. Therefore, the sensors are on 0.51 seconds every 3.5156 seconds, for an estimated, averaged current drain of 18 ma. This is considerably reduced from the 123 ma required if continuously powered, but still is the largest single power sink in the system using 39% of the total power. The power switch that controlled the OBS sensors was also used to turn on and off the power to a regulator supplying 5 volts to the Druck pressure sensor. It is not clear that the 1.2 ah per month power savings is worth switching the Druck pressure sensor or not. Also, there appears to be some signal in the regulated 5 volt supply which comes from the general voltage drop across the system battery pack (mostly across the blocking diodes) as the system and sensor power is switched on and off.

The electronics rack in the current meter has space for six packs of 12 "D" sized alkaline batteries. If grouped into 12v packs of 8 cells each, then the instrument case holds 9 parallel packs of batteries. The batteries are dioded together so that one bad cell will not draw down the battery pack with 1N5821 Schottky diodes, which only have a 0.23 v drop at 10 ma drain. (For comparison a simple 1N4002 diode has a 0.71 v drop at 10 ma drain.) At 20° C, a standard alkaline "D" cell provides about 12 ampere-hours of power at 25 ma drain when cut off at 1.1 volts. This puts the discharged battery pack voltage at about 9v where the Sea Bird sensors, and regulators start to fail. The 9 packs of 12 ah each, make a total pack of about 100 ampere hours. With our estimated total power requirements from Table 3, the instrument system should have a

TABLE 3: Power Requirements and Budget

SubSystem	Power Used	Power Source	Duty Cycle	Average Power
Microprocessor Data System	6.35 ma Standby	Regulated CPU 5.15 v	Continuous	6.3 ma
	86 ma for 0.3s 19 ma s/3.5s Processing	CPU Regulated Switched 5.15v	0.300 s every 3.5156 s	5.4 ma
Compass & Vane	4.87 ma (2.44 ma each)	Switched, XP25 Regulated 4.87v	0.51 s every 3.5156 s	0.4 ma
Tilt Sensors	0.70 ma (0.35 ma each)	Regulated CPU 5.15 v	Contiuous CPU 5.15v	0.7 ma
Sea Bird T & C	14.0 ma	System 12v Battery	Continuous	14.0 ma
Paroscientific P	1.0 ma	System 12v Battery	Continuous	1.0 ma
OBS sensors	123.8 ma	Switched System 12 v Battery	0.51s every 3.5156 s	18.0 ma
Druck Pressure	2.066 ma	Own Regulated, Switched 5v	0.51 s every 3.5156 s	0.3 ma
Total Power From 12 v Battieries				46.1 ma = 33 ah/month

projected life of about 2000 hours, 83 days or 12 weeks. This is considerably lengthened from the full powered life with three OBS sensors of three days in the Oyster River test, or the 1 day duration with Packet Radio telemetry in the 1989 New York Bight test.

For the summer 1993 deployment, the battery pack was configured as a single pack of 9 paralleled 12 volt batteries. It may make sense to divide the pack into 3 equal pieces. The CTD part of the system draws about 17 ma; the OBSs draw about 18 ma; and the recording system draws 13 ma. Therefore, the three power requirements are about equal. The lower system requirement gives that supply a greater safety factor. Also this division would isolate the switched OBS sensors from the continuously powered CTD sensors, and leave the system power isolated from both sensor systems, which are more easily subject to failure and premature discharge.

1.4.2. Sampling Software Modifications: The principle modification to the sampling software was in the event sampling logic. The averaging and bursting features appeared to be functioning properly, but previous results indicated that the event sampling could use revision. First, the logic declaring an event was changed, so that a value exceeding the critical level must be seen by a sensor on two consecutive samples. This filters out an event being declared by a single spike in the observations caused by a noisy sensor, a leaf or fish getting in front of a sensor and causing only one large value. Then, when an event has been declared, a 16 sample buffer of previous values is dumped to memory, and successive samples written as event records until the event is declared over. The event is over when 16 consecutive samples no longer exceed the critical level, and then the recording is turned off. For the speed and OBS sensors, the critical level was set to be twice the mean from the start of the experiment. For speed, the instantaneous speed must also exceed 42.7 cm/sec to eliminate the possibility of low speeds triggering events. This criteria for velocity might have to be changed to eliminate the large tidal signals from triggering events.

The conditional sampling algorithm was also modified for the pressure sensor. The pressure record was "first differenced" to prewhiten the data. This removes the mean pressure and just looks at the rate of change in signal. Then the standard deviation of these fluctuations are taken, and if the current pressure value exceeds two times the mean standard deviation since the start of the record, then a pressure trigger is declared. It was thought that this prewhitening to eliminate the mean, and emphasize the high frequency might bring out the wave signals and suppress the tides. However, the tides may still dominate the spectra and may cause event triggers. It might be wise to remove the pressure conditional sampling in future deployments and just use the speed and OBS sensors to declare potential sediment resuspension events. Selecting which sensors can trigger events can be done with the mask command during initialization (see Appendix D).

2.0. Field Operations in New York Bight Apex

The deployment of the bottom instrument system in the New York Bight in 1993 was the first time the system had been configured and deployed as designed, and the first opportunity to determine if the design and implementation of the basic ideas outlined in Baldwin, Bokuniewicz and Irish (1990) were viable. In spite of many minor problems, the two deployments in New York Bight Apex did show the basic ideas and implementation are sound, and that the instrument system has great potential for long term monitoring of shelf processes. As a first test of the full blown system in the open ocean with all sensors, and all the fancy sampling, this test was highly successful. Because the instrument was not changed significantly between deployments, the second deployment has many of the same problems seen in the first deployment, but again both deployments filled the memory with data which is used to study the instrument behavior as discussed below, and to begin to evaluate the physical environment at the 30 meter site in the New York Bight Apex.

2.1. Summary of Deployment One:

The instrument was trucked to New Jersey, and deployed in the Christiansen Basin from the R/V ONRUST on 5 May 1993. The site was selected from sidescan sonar records to be in a region of finer sediments between bands of coarser material in about 30 meters of water (Figure 1). The instrument was deployed at $40^{\circ} 23.502' N$ x $73^{\circ} 49.557' W$. A log of the deployment cruise is given in Appendix A. The instrument was turned around on 22 June 1993, the data retrieved, and the instrument redeployed for another month. A log of the turnaround and instrument replies is given in the Appendix B. The recovered data was then analyzed and the follow summary of the findings given.

1. The data storage was filled in 7 days - 33,381 records were saved, providing data from hourly averages, daily bursts and events triggered by the pressure and OBS sensors. The number of records saved from each sample type is indicated in Table 1. When the instrument was on deck during the turnaround and attached to a computer to monitor its operations, the time in the hardware and software counters was correct and the instrument was still taking proper 3.5156 second samples and averaging them. However, since the data storage was full, it could not save them. Obviously seven days of data from a 48 day deployment is not satisfactory, and either more restricted conditional sampling needs to be done, or the data storage expanded. Figures 8, 9, 10, and 11 show the hourly averaged records from the first deployment as a summary.
2. The instrument landed and stayed sitting on its end on the seafloor. The two tilt sensors (Figure 11a) are pegged at readings for horizontal position rather than vertical. Therefore, the speed record (Figure 8a) is only the component perpendicular to the current meter case, and a poor estimate of the true water velocity. The compass and vane follower (Figure 8b) do not give current direction, although the vane follower appears to show flow reversal with the tidal periodicity. The velocity components (Figure 8c) are geophysically useless, but illustrate that the vector averaging portion of the software worked properly.

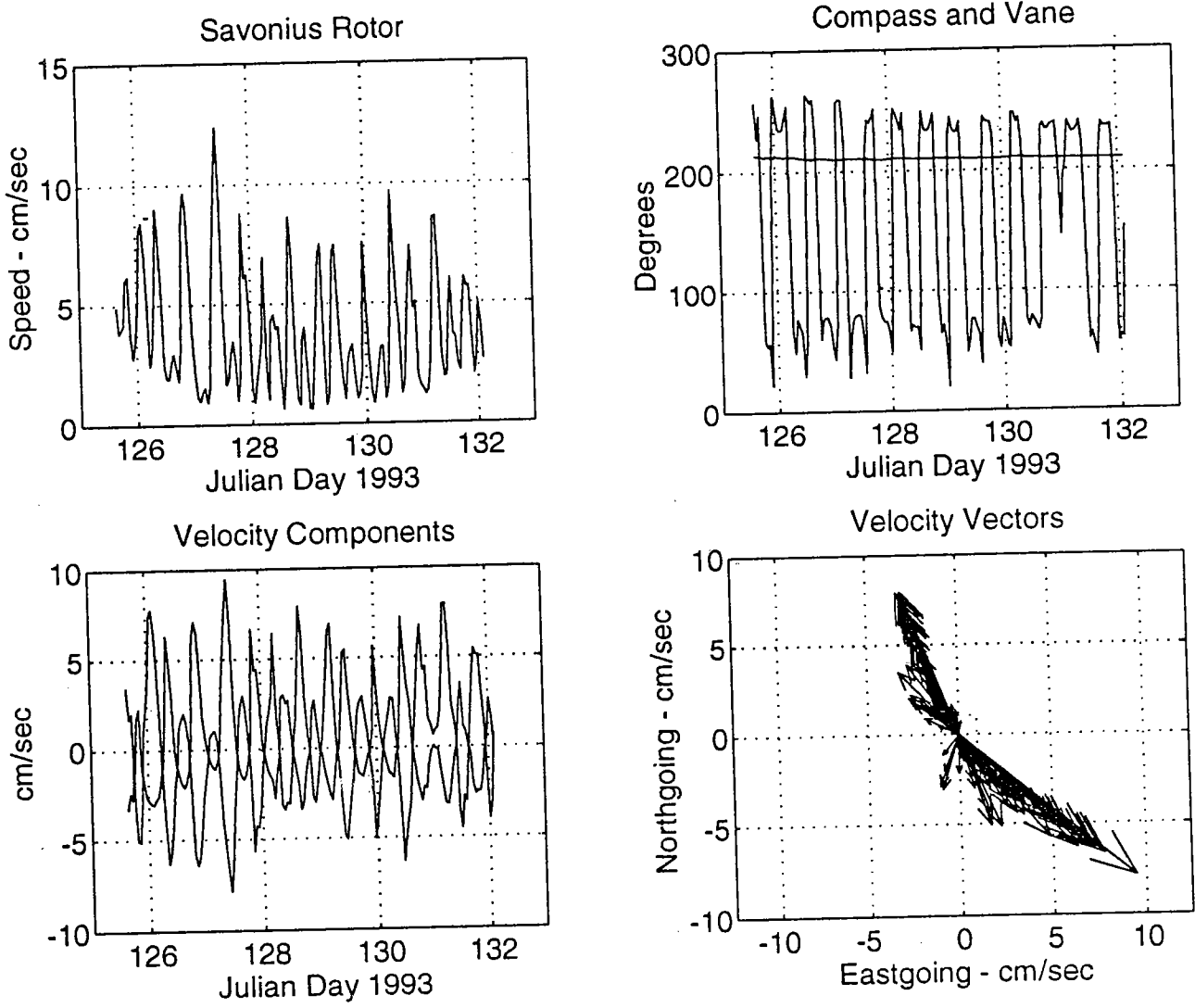

Figure 8. Hourly Velocity averages from deployment one in New York Bight. The speed (a) shows weak tidal currents and a low mean flow. The compass and direction (b) and velocity vectors (c) are unrealistic because of the instrument orientation on its side. Similarly the vector plot (d) is nonphysical, but indicates that the vector calculation is working properly.

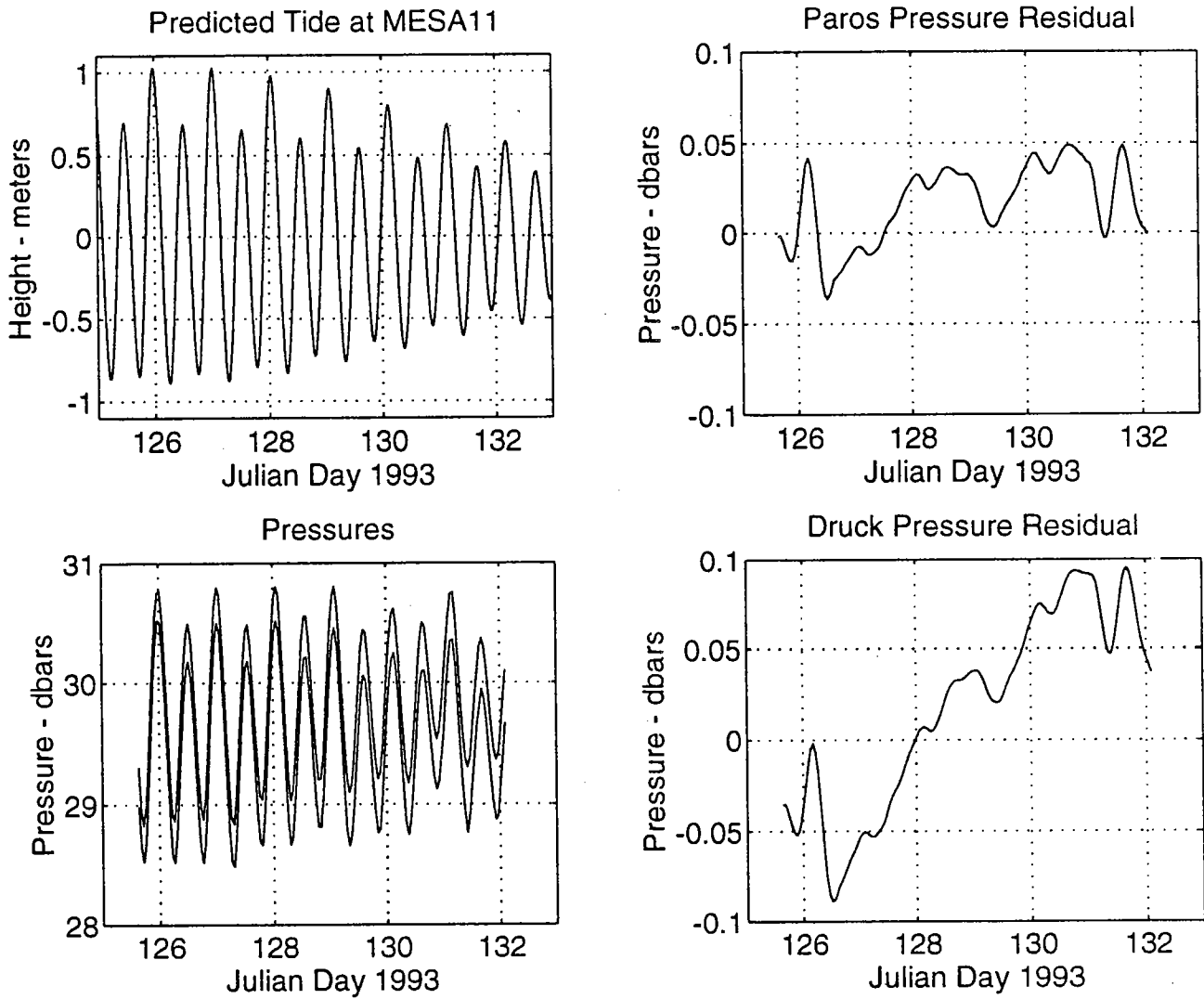

Figure 9. Hourly Pressure averages from deployment one in New York Bight. The tidal height (a) was predicted from previous nearby measurements from the MESA program. The Paroscientific and Druck bottom pressures (b) agree fairly well with a small mean offset and two residual pressures indicate little drift in the Paroscientific (b), and a possible small drift in the Druck (d) pressure sensors.

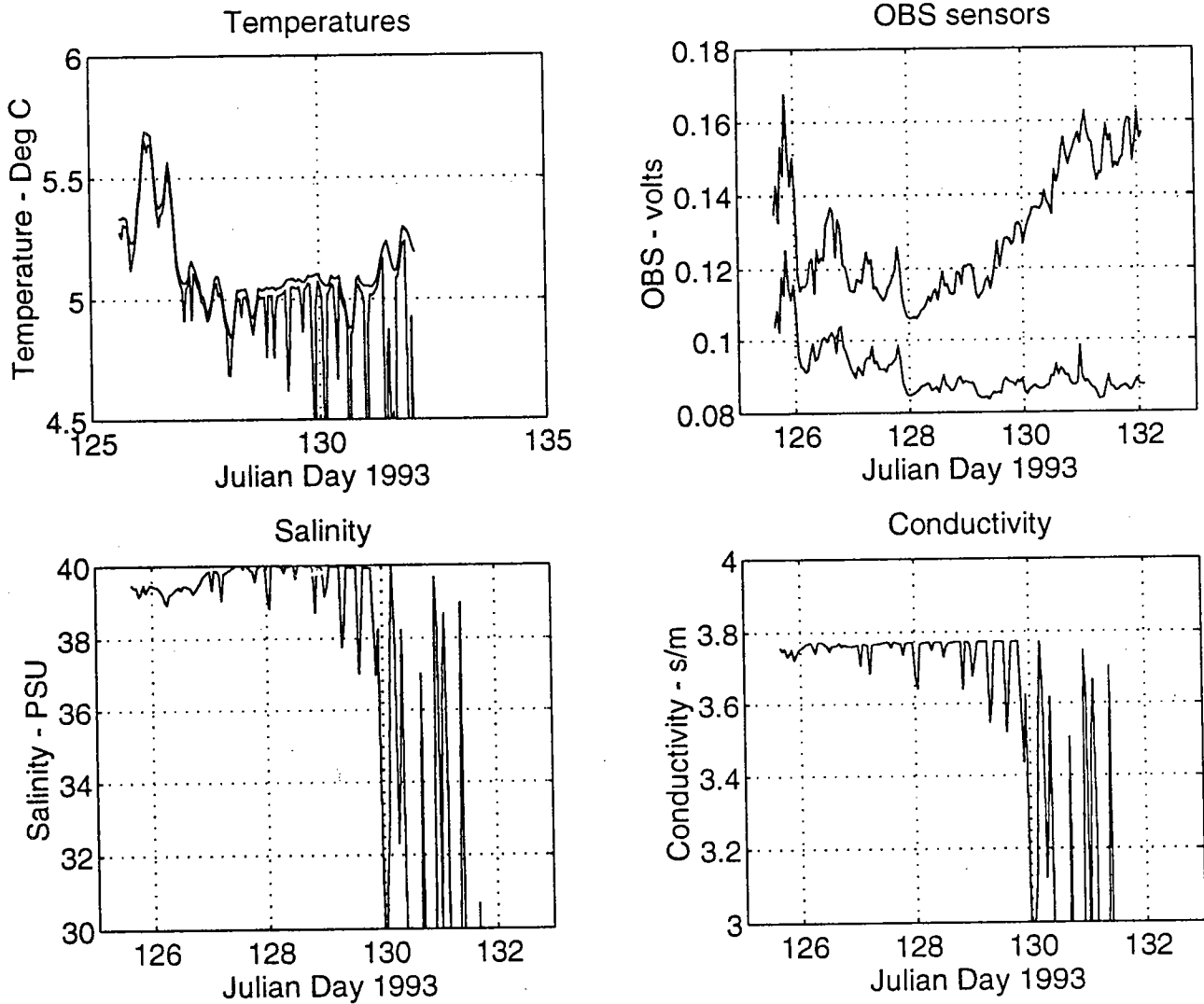

Figure 10. Hourly Physical Parameters from deployment one in New York Bight. The temperatures (a) from the Sea Bird and end cap thermistor show the obvious noise introduced by the cable, but otherwise are in agreement and show little fluctuations. The conductivities (c) and calculated salinities (d) are dominated by the cable noise effects. The OBS sensors (b) show a decreasing signal with time in OBS1 with an agreement in OBS2 at the start, then a drift in OBS2 toward higher values. The sensors were both about 46 cm above bottom looking up into the water column.

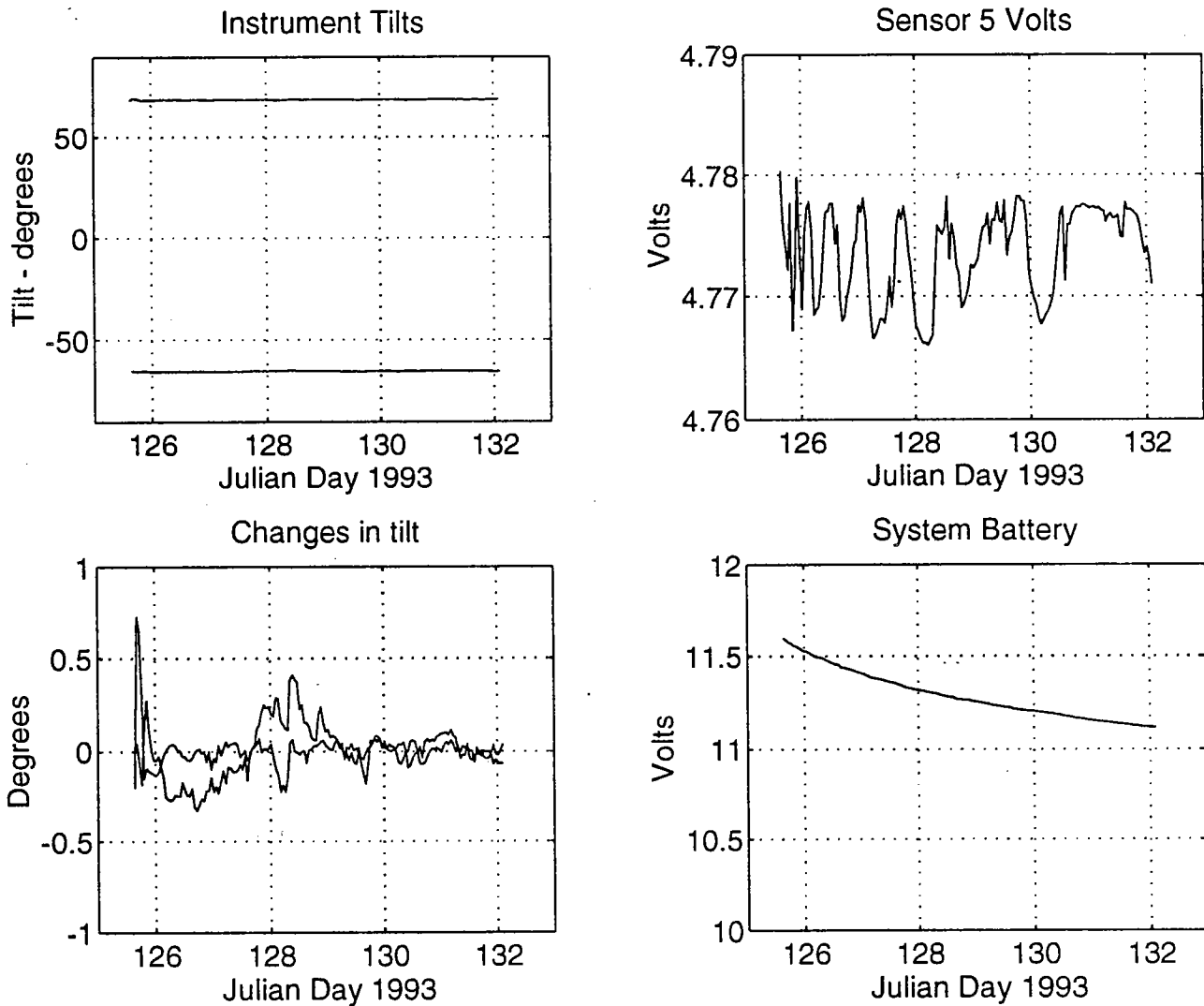

Figure 11. Hourly Diagnostics from deployment one in New York Bight. The two components of tilt (a) indicate the system on its end, and the changes in tilt with time (c) indicate no movement of the frame. The regulated sensor supply (b) indicates a constant voltage to within ± 0.005 volts. The system battery pack voltage (d) shows the battery decay with time.

3. The pressure sensors are not subject to instrument orientation. The Druck analog pressure sensor was deployed for a first time test in comparison with the Paroscientific pressure sensor costing about 6 times as much (\$425 plus pressure case & connector versus \$3,395). The comparison of the two sensors (Figure 9c) shows a 0.2 dbar difference in mean pressure, and nearly identical tidal excursions. Both records agree well with the tidal predictions (tidal constants from Moody, et al., 1984) made from an analysis of a 22 day pressure record (MESA11) taken nearby in 36 m of water (Figure 9a). The stability of the two sensors are shown in Figures 9b and 9d where the predicted tide has been subtracted and the results low-passed. There is no hint of low frequency drift in the Paroscientific pressure record, where the Druck sensor appears to drift toward greater pressure.

4. The thermistor end cap temperature sensor and the Sea Bird Temperature sensor are compared in Figure 10a. The agreement is reasonable considering the thermistor was not calibrated before this deployment, but the nominal factory calibration coefficients were used. The Sea Bird temperature sensor shows some problems with lower value spikes caused by signal dropouts due to cable problems. Although the splice was redone after the WHOI dock tests, the problem appears to grow worse with time. The conductivity record (Figure 10d) shows the same dropout problem, which again shows up in the calculated salinity record (Figure 10b.) The bottom temperature agrees with CTD profiles taken at deployment time (5.35°C), but the salinity appears about 8 PSU higher than the CTD profile (31.4 PSU). The cabling needs to be replaced before this salinity offset should be of any concern as earlier values from the Oyster River Test (Figure 6d) agreed well with CTD comparisons.

5. The two Downing OBS sensors (Figure 10b) appeared to work well. OBS 1 at 10 cm above bottom (bottom trace) shows means of about 0.09 v (about 0.09 mg/l concentrations) and little drift with time. OBS2 at 1 m above bottom (top trace) shows initially higher values of about 0.11v and drifts with time. The "zero" point of both sensors was adjusted in the laboratory so that both sensors had an offset of about 0.1 volts in air and not with "clear water" from the site. Therefore, an arbitrary "adjustment" needs to be made to correct for the zero offset. (Setting the zero reading to positive voltage ensures that the signal will not go below zero which the A/D converter would then show as a zero.) The initial 70 hours show nearly identical results with a higher suspended sediment concentration during the first 10 hours. Then the OBS2 shows significant drift of about 0.001 volt per hour. This may have been partially due the orientation of the instrument frame with the OBS sensors looking outward and upward. Sediment settling on the sensor or biofouling of the sensor could cause the drift toward higher backscattering. This drift may present problems in the event sampling algorithm in long deployments and was observed in deployment two. More long term experience is needed with these sensors in this application at this site.

6. The regulated 5 volt supply (Figure 11b), switched to conserve power drawn by the analog sensors (pressure, compass, and vane follower), is fairly constant over the duration within a typical 0.01 volt range. The system battery voltage is also monitored (Figure 11d) and shows a typical decay of the batteries which allows a check to be made on the rate of discharge and the estimated battery life remaining. At recovery time the battery voltage during active sampling was 10.4v which implied that about 9 ampere hours or 3/4 of the battery life had been used.

Therefore, the estimated battery life is about 64 days, or 3/4 that originally estimated based on laboratory current drain estimates. This reflects the uncertainty in estimating the life with the "pulsed on an off" mode of current drain.

7. The 512 point pressures bursts were taken at 24 hour intervals at about high tide. Spectra of the six records are shown summarized in Figure 12. A strong peak is seen just below 0.3 Hz which is related to the 3.5156 second basic sampling interval. It is disturbing that this peak is so large it masks the more general peaks which appear around 10 seconds (0.1 HZ) and 5.5 seconds (0.18 Hz) which are the wave energy that we want to measure. The peak at 0.3 Hz must be associated with the power up and sampling of all circuits every 3.5156 seconds that is not compensated for by the regulator.

8. The OBS sensors triggered five identifiable sediment events during the week of the first deployment (see Table 4A and Figure 13). Figure 14a and 14b show the closer looks at the hourly averages, the 3.5156 second event sampled records and the critical level used to determine an event (two times the mean value from the start of the experiment). OBS1 only identifies event #3 at 11PM on 10 May 1993 (JD 130). The single points seen by OBS1 near the start and OBS2 between events 2 and 3 are above the critical level but did not trigger an event, as we require two successive points above the critical level to start recording. Figure 14c and 14d show the OBS records for events three and five. In these plots the times have been set to zero at the time the instrument identified a trigger for an event record. The events are small events which last for a minute or two and are nicely resolved by the event sampling algorithm. Four of the events are only seen by only OBS2 (e.g. Figure 14c), and therefore are probably a local event such as a fish or debris in the water. Event three (Figure 14d) is more complicated and shows up on both OBS sensors. Event three is also seen on the speed record as the highest speed, and therefore, probably indicative of a sediment resuspension event, although with the current meter horizontal, the velocity is not properly resolved, so we can not say for certain what is going on, but it is maddeningly close to resolving events as we desired.

9. The majority of the events, particularly as time progressed, were triggered by the Paroscientific pressure sensor (Figure 13). This conditional sampling feature had never been tested before. The pressure record is first differenced to remove the mean and this prewhitening tends to over emphasize the high frequency signal, particularly the noise due to cabling problems. Also there is an error in the algorithm estimating the critical and event detection. The standard deviation was calculated, then the square root taken, rather than estimating the variance and taking the square root. Hence, the critical level was lower than desired, and this triggered all the other events. It is nice to be able to explain the event sampling behavior, but it also would have been nicer to have it work right the first time.

10. Figure 15 shows the 3.5156 second speed data compared with the hourly averages, and critical levels. The event trigger flag showed that there were no speed events identified. That is because we insisted that the count be above 8 counts in 3.5156 seconds (42.7 cm/sec) as well as the level be twice the mean speed. Figure 15 (top panel) shows the critical level at twice the average speed from the start of the deployment. Although greater than twice the mean, the speeds did not exceed 42.7 cm/sec and so no speed events were triggered. It is clear that the

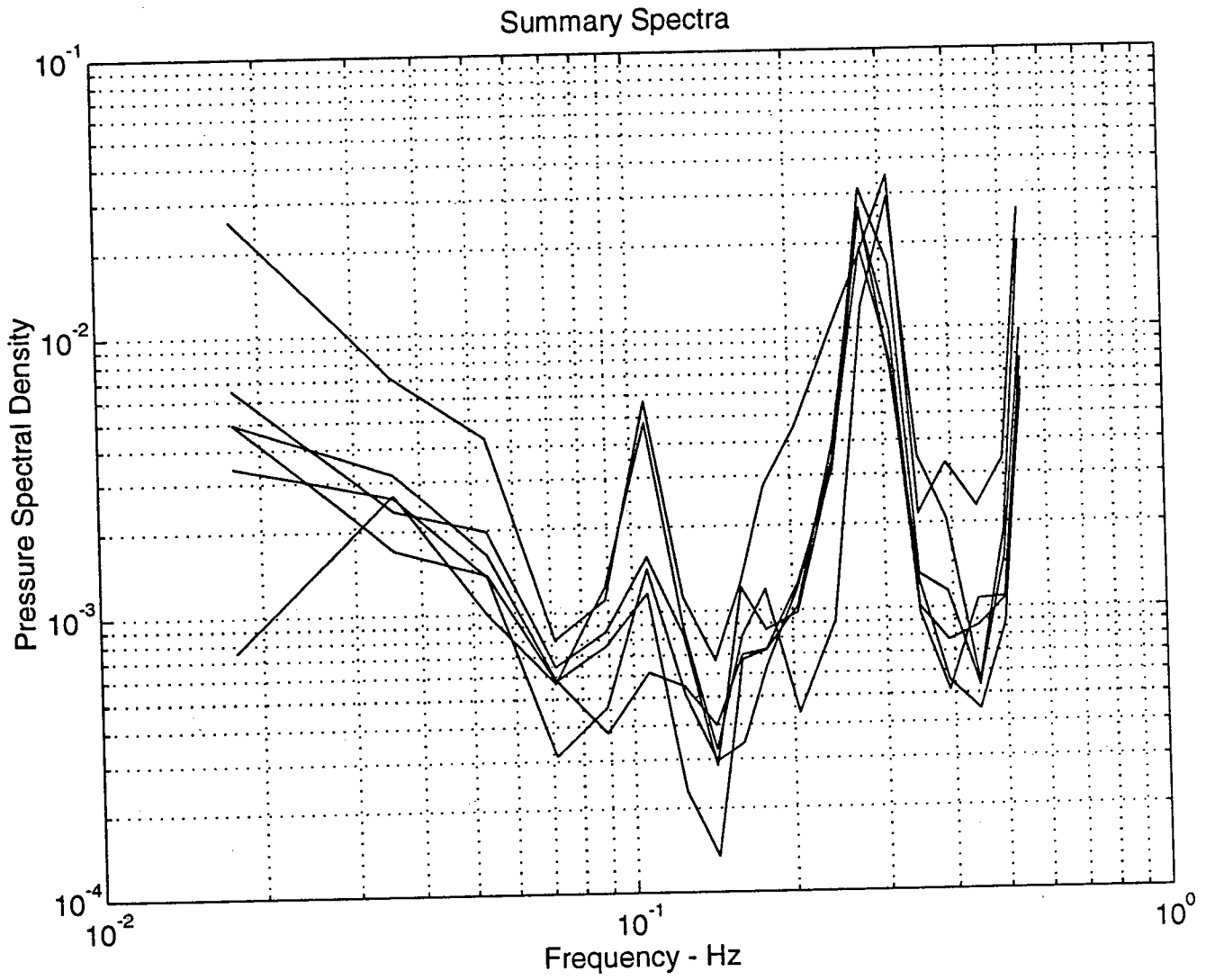

Figure 12. Burst Pressure Spectra from deployment one in New York Bight. A summary of the six burst sampled pressure spectra with no corrections for attenuation made. The peaks just above 0.1 and 0.18 Hz correspond to 9 and 6 second waves respectively. The peak at 0.3 Hz is probably instrumental.

TABLE 4A: Events from New York Bight

Deployment	Identity	Start:End Term	Date of Event (Julian Day)	Time of Event Trigger	Triggered By	Comments: Seen in -
One	Event 1	405:454	6 May 1993 (126)	09:36:37	Press/OBS2	OBS2 only
	Event 2	703:738	9 May 1993 (129)	12:18:55	OBS2	OBS2 only
	Event 3	1398:1453	10 May 1993 (130)	22:59:00	OBS1	OBSs/Speed
	Event 4	3151:3195	11 May 1993 (131)	11:37:08	OBS2	OBS2 only
	Event 5	7136:7177	11 May 1993 (131)	20:51:51	OBS2	OBS2 only
Two	Event 1	1:31	24 June 1993 (175)	00:09:47	OBS1	OBS1 only
	Event 2	32:63	24 June 1993 (175)	20:03:05	OBS1	OBS1 only
	Event 3	64:99	25 June 1993 (176)	08:47:12	OBS2	OBS2 only
	Event 4	100:136	25 June 1993 (176)	19:57:27	OBS2	OBS2 only
	Event 5	137:167	25 June 1993 (176)	20:02:58	OBS1	OBS1 then OBS2
	Event 6	168:198	26 June 1993 (177)	07:37:18	OBS1	OBS1 only
	Event 7	199:246	29 June 1993 (180)	14:55:17	OBS1	OBS/Spd/Prs/Comp
	Event 8	247:277	1 July 1993 (182)	02:55:14	OBS1	OBS1 only
	Event 9	278:308	2 July 1993 (183)	01:32:22	OBS2	OBS2 only
	Event 10	309:350	2 July 1993 (183)	02:21:25	OBS1	OBS/Spd/Prs/Comp
	Event 11	351:384	2 July 1993 (183)	02:24:07	OBS2	OBS2 only
	Event 12	385:415	2 July 1993 (183)	09:37:56	OBS2	OBS2/Spd
	Event 13	416:446	2 July 1993 (183)	18:40:17	OBS2	OBS2 only
	Event 14	447:477	2 July 1993 (183)	18:43:55	OBS2	OBS2 only
	Event 15	478:508	2 July 1993 (183)	19:12:59	OBS2	OBS2 only
	Event 16	509:539	2 July 1993 (183)	19:17:44	OBS2	OBS2 only
	Event 17	540:573	3 July 1993 (184)	15:54:10	OBS1	OBS1 only
	Event 18	574:604	4 July 1993 (185)	17:36:11	OBS2	High OBS2
	Event 19	605:635	4 July 1993 (185)	17:46:51	OBS2	High OBS2
	Event 20	636:675	4 July 1993 (185)	17:48:57	OBS2	High OBS2
	Event 21	676:697	4 July 1993 (185)	17:50:5	OBS2	High OBS2
	Event 22	698:741	4 July 1993 (185)	18:05:36	OBS2	High OBS2
	Event 23	742:784	4 July 1993 (185)	18:07:28	OBS1	OBS1 only
	Event 24	785:816	4 July 1993 (185)	18:12:41	OBS2	High OBSs
	Event 25	817:848	4 July 1993 (185)	18:16:02	OBS2	High OBS2

TABLE 4B: Events from New York Bight

Deployment	Identity	Start:End Term	Date of Event (Julian Day)	Time of Event Trigger	Triggered By	Comments: Seen in -
Two	Event 26	849:884	4 July 1993 (185)	18:56:45	OBS1	OBS1 only
	Event 27	885:915	6 July 1993 (187)	02:49:15	OBS2	OBS2 only
	Event 28	916:946	6 July 1993 (187)	10:08:32	OBS1	OBS1/Spd/Pres/Dir
	Event 29	947:977	6 July 1993 (187)	21:05:32	OBS1	OBS1 only
	Event 30	978:1008	6 July 1993 (187)	21:12:27	OBS1	OBS1 only
	Event 31	1009:1049	7 July 1993 (188)	01:39:59	OBS1	OBS1 only
	Event 32	1050:1080	7 July 1993 (188)	08:36:04	OBS2	High OBSs
	Event 33	1081:1111	7 July 1993 (188)	08:51:46	OBS1	OBS1 only
	Event 34	1112:1142	7 July 1993 (188)	11:45:02	OBS2	OBS2 only
	Event 35	1143:1173	7 July 1993 (188)	16:37:49	OBS1	OBS1 only
	Event 36	1174:1214	8 July 1993 (189)	01:01:19	OBS1	OBS1 only
	Event 37	12115:1247	8 July 1993 (189)	03:01:23	OBS1	OBS1 only
	Event 38	1248:1278	8 July 1993 (189)	08:49:22	OBS2	High OBS2
	Event 39	1279:1309	8 July 1993 (189)	12:30:16	OBS1	OBS1 only
	Event 40	1310:1342	8 July 1993 (189)	15:07:28	OBS1	OBS1/Dir/Press
	Event 41	1343:1411	8 July 1993 (189)	21:50:43	OBS2	High OBS2
	Event 42	1412:1464	8 July 1993 (189)	21:55:21	OBS2	High OBS2
	Event 43	1465:1505	8 July 1993 (189)	21:59:16	OBS2	High OBS2
	Event 44	1506:1542	8 July 1993 (189)	22:01:09	OBS2	High OBS2
	Event 45	1543:1581	8 July 1993 (189)	22:04:04	OBS2	High OBS2
	Event 46	1582:1609	8 July 1993 (189)	22:05:57	OBS2	High OBS2
	Event 47	1610:1635	8 July 1993 (189)	22:07:21	OBS2	High OBS2
	Event 48	1636:1701	8 July 1993 (189)	22:14:13	OBS2	High OBS2
	Event 49	1702:1730	8 July 1993 (189)	22:17:29	OBS2	High OBS2
	Event 50	1731:1767	8 July 1993 (189)	22:35:32	OBS2	OBS2 only
	Event 51	1768:1800	9 July 1993 (190)	01:42:34	OBS1	OBSs
	Event 52	1801:1831	9 July 1993 (190)	03:25:10	OBS1	OBS 1 only
	Event 53	1832:1862	9 July 1993 (190)	07:06:14	OBS2	High OBS2
	Event 54	1863:1934	9 July 1993 (190)	07:12:06	OBS2	High OBS2
	Event 55	1935:1965	9 July 1993 (190)	07:17:22	OBS2	High OBS2

TABLE 4C: Events from New York Bight

Deployment	Identity	Start:End Term	Date of Event (Julian Day)	Time of Event Trigger	Triggered by	Comments: Seen in -
Two	Event 56	1966:2015	9 July 1993 (190)	07:21:43	OBS2	High OBS2
	Event 57	2016:2044	9 July 1993 (190)	07:23:53	OBS2	High OBS2
	Event 57	2045:2081	9 July 1993 (190)	07:26:41	OBS2	High OBS2
	Event 59	2082:2162	9 July 1993 (190)	07:33:29	OBS2	OBS2 only
	Event 60	2163:2211	9 July 1993 (190)	07:37:42	OBS2	High OBS2
	Event 61	2212:2253	9 July 1993 (190)	07:40:07	OBS2	High OBS2
	Event 62	2254:2384	9 July 1993 (190)	07:42:03	OBS2	High OBS2
	Event 63	2385:2440	9 July 1993 (190)	07:49:01	OBS2	High OBS2
	Event 64	2441:2546	9 July 1993 (190)	07:51:43	OBS2	High OBS2
	Event 65	2547:2756	9 July 1993 (190)	07:57:38	OBS2	High OBS2
	Event 66	2757:2795	9 July 1993 (190)	08:09:56	OBS2	High OBS2
	Event 67	2796:2836	9 July 1993 (190)	08:11:56	OBS2	High OBS2
	Event 68	2837:3091	9 July 1993 (190)	08:13:48	OBS2	High OBS2
	Event 69	3092:3117	9 July 1993 (190)	08:28:23	OBS2	OBS2 only
	Event 70	3118:3388	9 July 1993 (190)	08:30:30	OBS2	OBS/Spd/Prs/Comp
	Event 71	3389:3420	9 July 1993 (190)	10:51:50	OBS1	OBSs
	Event 72	3421:3453	9 July 1993 (190)	10:56:10	OBS2	High OBS2
	Event 73	3454:3503	9 July 1993 (190)	15:58:41	OBS2	High OBS2
	Event 74	3504:3563	9 July 1993 (190)	11:01:23	OBS2	OBS2 only
	Event 75	3564:3588	9 July 1993 (190)	11:04:11	OBS2	OBS2 only
	Event 76	3589:3691	9 July 1993 (190)	11:07:56	OBS2	OBS2 only
	Event 77	3692:3722	9 July 1993 (190)	11:17:29	OBS1	OBS1 only
	Event 78	3723:3754	9 July 1993 (190)	12:04:57	OBS1	OBS1 only
	Event 79	3755:3785	9 July 1993 (190)	12:39:42	OBS1	OBS1 only
	Event 80	3786:3816	9 July 1993 (190)	13:11:17	OBS1	OBS1 only
	Event 81	3817:3847	9 July 1993 (190)	13:24:45	OBS1	OBS1 only
	Event 82	3848:3878	9 July 1993 (190)	13:54:17	OBS1	OBS1 only
	Event 83	3879:3910	9 July 1993 (190)	15:11:31	OBS2	OBS2 only
	Event 84	3911:3949	9 July 1993 (190)	15:40:24	OBS1	High OBSs
	Event 85	3950:3972	9 July 1993 (190)	15:42:17	OBS2	High OBSs

TABLE 4D: Events from New York Bight

Deployment	Identity	Start:End Term	Date of Event (Julian DayP	Time of Event Trigger	Triggered By	Comments: Seen in -
Two	Event 86	3973:4012	9 July 1993 (190)	15:46:30	OBS2	High OBSs
	Event 87	4013:4034	9 July 1993 (190)	15:48:22	OBS2	OBS2 only
	Event 88	4035:4070	9 July 1993 (190)	16:12:17	OBS2	OBS2 only
	Event 89	4071:4134	9 July 1993 (190)	16:14:13	OBS2	OBS2 only
	Event 90	4135:4174	9 July 1993 (190)	16:22:18	OBS2	OBS2 only
	Event 91	4175:4207	9 July 1993 (190)	16:24:10	OBS2	OBS2 only
	Event 92	4208:4275	9 July 1993 (190)	16:25:31	OBS2	OBS2 only
	Event 93	4276:4302	9 July 1993 (190)	16:28:48	OBS2	OBS2 only
	Event 94	4303:4332	9 July 1993 (190)	16:28:58	OBS2	OBS2 only
	Event 95	4333:4366	9 July 1993 (190)	16:31:23	OBS2	OBSs
	Event 96	4367:4431	9 July 1993 (190)	16:34:08	OBS2	OBSs
	Event 97	4432:4517	9 July 1993 (190)	16:40:03	OBS2	OBS2 only
	Event 98	4518:4556	9 July 1993 (190)	16:44:51	OBS2	OBS2 only
	Event 99	4557:4595	9 July 1993 (190)	16:46:26	OBS2	OBS2 only
	Event 100	4596:4708	9 July 1993 (190)	16:47:58	OBS2	OBS2 only
	Event 101	4709:4793	9 July 1993 (190)	16:53:56	OBS2	OBS2 only
	Event 102	4794:5052	9 July 1993 (190)	16:58:16	OBS2	OBS2 only
	Event 103	5053:5089	9 July 1993 (190)	16:46:26	OBS1	OBS1 only
	Event 104	5090:5127	9 July 1993 (190)	21:05:24	OBS1	OBS1 only
	Event 105	5128:5162	9 July 1993 (190)	22:08:21	OBS1	OBS1 only
	Event 106	5163:5197	9 July 1993 (190)	22:24:02	OBS2	OBS2 only
	Event 107	5198:5224	9 July 1993 (190)	22:30:55	OBS2	High OBS2
	Event 108	5225:5255	9 July 1993 (190)	22:32:51	OBS2	OBS2 only
	Event 109	5256:5286	9 July 1993 (190)	22:38:11	OBS2	OBS2 only
	Event 110	5287:5317	9 July 1993 (190)	22:53:42	OBS2	High OBS2
	Event 111	5318:5350	9 July 1993 (190)	22:56:48	OBS1	OBS1 only
	Event 112	5351:5384	9 July 1993 (190)	23:13:27	OBS2	OBS2 only
	Event 113	5385:5416	9 July 1993 (190)	23:31:12	OBS2	OBS2 only
	Event 114	5417:5687	10 July 1993 (191)	02:36:57	OBS1	High OBS1
	Event 115	5688:4958	10 July 1993 (191)	04:51:53	OBS1	High OBS1

TABLE 4E: Events from New York Bight

Deployment	Identity	Start:End Term	Date of Event (Julian Day)	Time of Event Trigger	Triggered By	Comments: Seen in -
Two	Event 116	5959:5989	10 July 1993 (191)	08:26:13	OBS2	OBS2 only
	Event 117	5990:6020	10 July 1993 (191)	08:58:55	OBS1	High OBS1
	Event 118	6021:6087	10 July 1993 (191)	09:01:02	OBS1	OBS1 only
	Event 119	6088:6118	10 July 1993 (191)	09:34:08	OBS1	OBS1 only
	Event 120	6119:6160	10 July 1993 (191)	09:36:43	OBS1	OBS1 only
	Event 121	6161:6191	10 July 1993 (191)	09:38:35	OBS1	OBS1 only
	Event 122	6192:6235	10 July 1993 (191)	09:43:48	OBS1	High OBS1
	Event 123	6236:6269	10 July 1993 (191)	09:45:41	OBS1	High OBS1
	Event 124	6270:6303	10 July 1993 (191)	09:57:48	OBS1	OBS1 only
	Event 125	6304:6360	10 July 1993 (191)	10:04:40	OBS1	OBS1 only
	Event 126	6361:6388	10 July 1993 (191)	10:07:21	OBS1	High OBS1
	Event 127	6389:6419	10 July 1993 (191)	10:14:58	OBS1	High OBS1
	Event 128	6420:6450	10 July 1993 (191)	10:17:19	OBS1	High OBS1
	Event 129	6451:6481	10 July 1993 (191)	10:19:33	OBS1	High OBS1
	Event 130	6482:6527	10 July 1993 (191)	10:22:07	OBS1	High OBS1
	Event 131	6528:6563	10 July 1993 (191)	10:24:35	OBS1	High OBS1
	Event 132	6564:6655	10 July 1993 (191)	10:29:41	OBS1	High OBS1
	Event 133	6656:6730	10 July 1993 (191)	10:35:29	OBS1	High OBS1
	Event 134	6731:6771	10 July 1993 (191)	10:40:31	OBS1	High OBS1
	Event 135	6772:6839	10 July 1993 (191)	10:42:34	OBS1	High OBS1
	Event 136	6840:6876	10 July 1993 (191)	10:48:01	OBS1	High OBS1
	Event 137	6877:7068	10 July 1993 (191)	10:49:54	OBS1	High OBS1
	Event 138	7069:7286	10 July 1993 (191)	11:00:56	OBS1	High OBS1
	Event 139	7287:7543	10 July 1993 (191)	11:11:38	OBS1	High OBS1
	Event 140	7544:7814	10 July 1993 (191)	13:25:49	OBS1	High OBS1
	Event 141	7815:8006	10 July 1993 (191)	15:41:17	OBS1	High OBS1
	Event 142	8007:8267	10 July 1993 (191)	15:52:00	OBS1	High OBS1
	Event 143	8268:8538	10 July 1993 (191)	18:06:32	OBS1	High OBS1
	Event 144	8539:8809	10 July 1993 (191)	20:21:29	OBS1	High OBS1
	Event 145	8810:9080	10 July 1993 (191)	22:36:52	OBS2	High OBSs
	Event 146	9081:9311	10 July 1993 (191)	22:48:12	OBSs	High OBSs

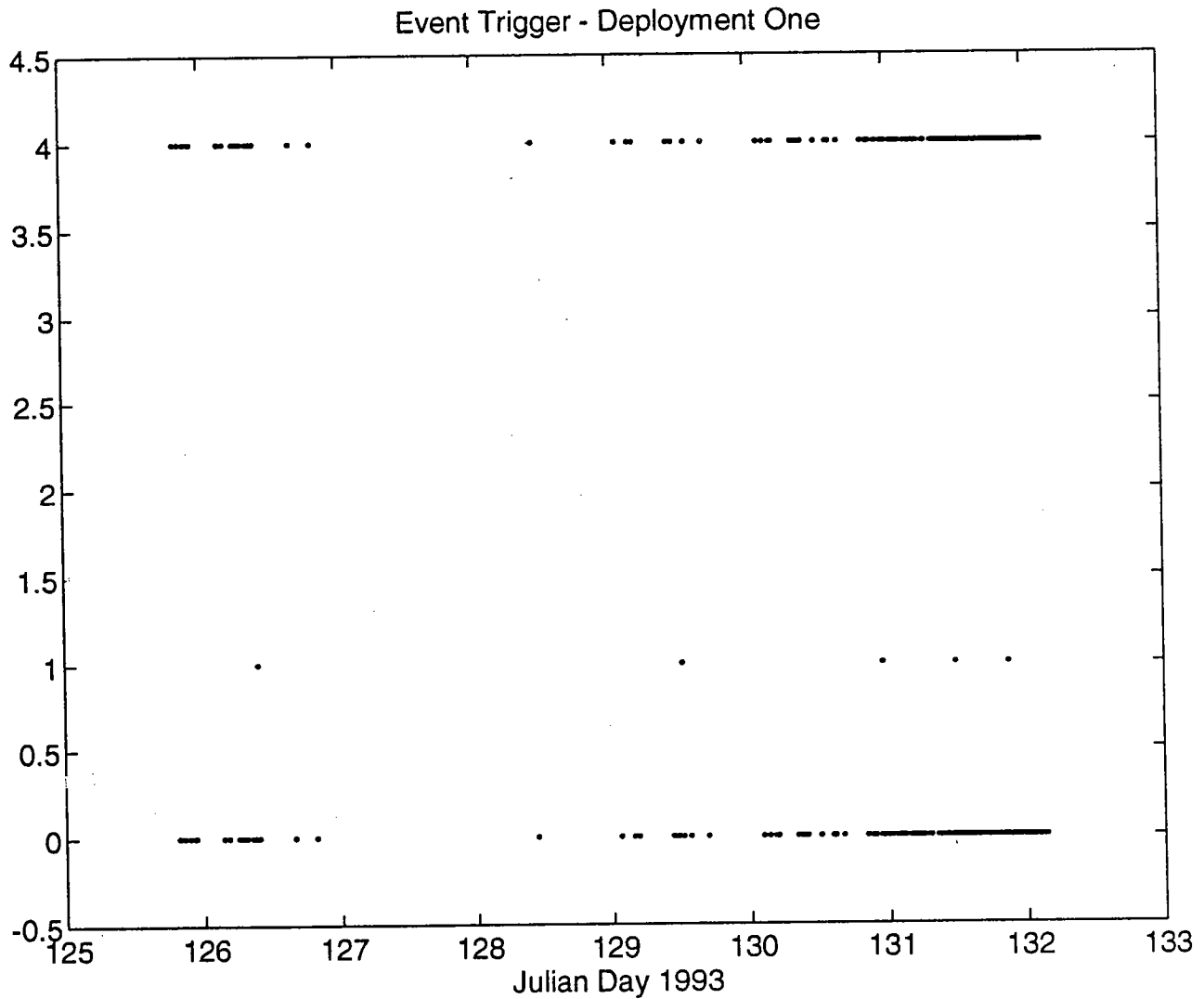

Figure 13. Event Flags for deployment one in New York Bight. The flag which triggers an event is recorded with the event and is used to help reconstruct what was happening. A value of 0 corresponds to no signal was above critical, a value of 1 indicates that one of the OBS sensors was critical, a value of 2 indicates that a speed was critical, and a value of 4 represents a pressure critical. Unfortunately, the logic of combining this flag was not set to indicate if multiple flags were set, although we expect that event one has both a pressure and OBS critical. The five OBS events are clearly indicated by the flag having value 1, and events 3 and 5 are plotted in Figure 14.

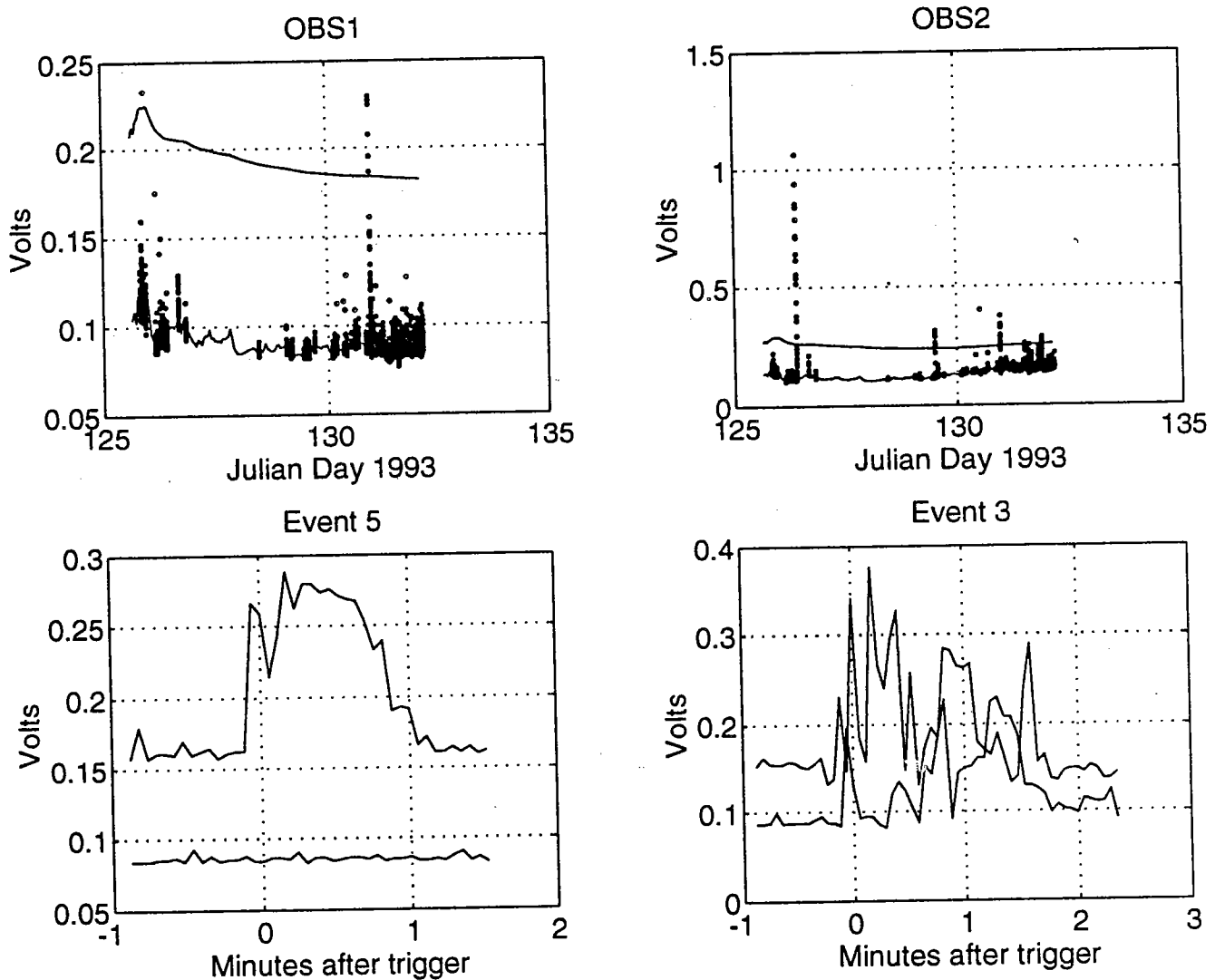

Figure 14. OBS Events from deployment one in New York Bight. The top panels show the records from OBS1 and OBS2. The bottom solid line is the hourly averages while the top solid line is the critical level which triggers event recording. The dots are the event samples, and when they exceed the critical level, then an event is recorded. The bottom two panels show two examples of events. Event 5 (c) is typical of four events in which only one OBS sensor sees the signal which is probably due to a fish or floating debris. Event 3 (d) is different in that there is a spike in velocity, and signals are seen on both OBS sensors.

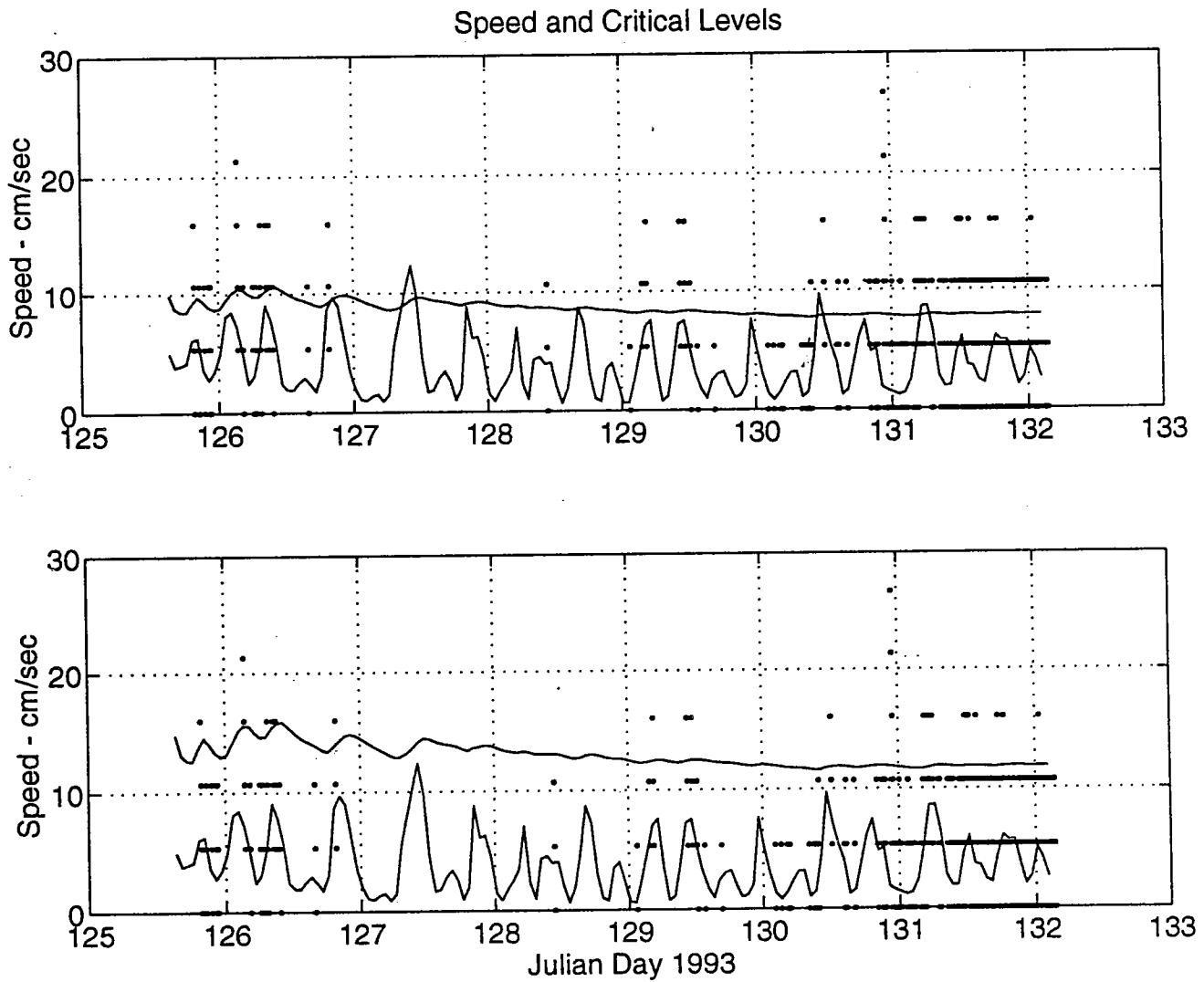

Figure 15. Speed events from deployment one in New York Bight. The two panels show the hourly averages (bottom solid line), the critical level (top solid line) and event samples (dots). The top panel shows the critical level as used, which would allow normal tidal currents to trigger events. The bottom panel shows the critical set to three times the mean from the start of the event which eliminates all normal tidal velocities from triggering events. No speed events were declared (Figure 13) because in addition to being critical, the level must also be above 42.7 cm/sec (8 counts in 3.5156 seconds).

critical level should be at least 3 times the mean speed (bottom panel), to assure that no standard tidal signals trigger events. Then the extra high wave energy will trigger an event in conjunction with the tidal and mean currents, which is what is desired.

11. The event flags shown in Figure 13 are recorded as diagnostics to determine what sensor the instrument determined as having excess energy. The values of this flag and its meaning are listed below:

- 0 - no critical
- 1 - either (or both) OBS sensor is above critical
- 2 - speed is above critical
- 3 - speed and either OBS sensor are above critical
- 4 - first differenced pressure is above critical
- 5 - first differenced pressure and either OBS sensor are above critical
- 6 - first differenced pressure and speed are above critical
- 7 - first differenced pressure, speed and either OBS sensor are above critical.

In the summer 1993 deployments a logic error set this flag to the lowest value rather than the logical "OR" of all the critical flags. Event 1 was first triggered by pressure and then by OBS2, so probably the flag should have started out at 4 then jumped to 6 rather than to 2.

2.3. Summary of Deployment Two:

The instrument was recovered and deployed from the R/V ONRUST on 22 June 1993. The instrument was deployed at 40° 23.51' N x 73° 49.22' W (Figure 1) which was as close to the initial deployment position as possible. A log of the turnaround cruise is given in the Appendix B. The instrument was finally recovered on 28 July 1993, the data retrieved, and the instrument trucked back to WHOI for further modifications and testing. A log of the recovery cruise and instrument replies is given in the Appendix C. The recovered data was then analyzed and the follow summary of the findings given.

1. Because the instrument was observed to be falling with the current meter horizontal on the first deployment, calculations were done at WHOI which showed that the center of buoyancy, mass and drag were not optimum and there was the potential of the instrument's landing and staying on its end (as indeed happened). Therefore, for the turnaround, two 17" Benthos glass flotation spheres were brought along and attached to the frame. This duplicated the configuration used successfully in the Oyster River tests, and indeed worked well here. The instrument landed upright, with the current meter tilted about 1.0° on one axis and 0.4° on the other (Figure 19a). The tilts remained constant within a few tenths of a degree, indicating that the instrument did not move on or settle significantly into the sea floor.

2. For this deployment the averaging interval was changed to 0.5 hour (see Table 1). The data system appeared to work well, and filled the memory in 18 days. The system continued to function after this time, but data could not be saved. To easily increase the deployment time, adding a larger data storage device would be a very cost effective improvement as it was the

limiting factor in both deployments. To exhaust the batteries, the data storage would have to be increased by at least six fold to about 4 MBytes. Alternatively, the conditional sampling algorithm could be made more restrictive, and the pressure, which triggered many events when the cabling problem caused noise, could be eliminated from the conditional sampling algorithm with little loss. For deployment two, the pressure and speed were not used to trigger events. Figure 16, 17, 18, and 19 show the half hourly averaged data from the second deployment as a summary.

3. Again the principle signal seen is tidal, with currents of 10 to 15 cm/sec (Figure 15a). There is obviously some low frequency signal in the velocity records (Figure 15c), which modulate the tidal currents. The vector plot (Figure 15d) shows the flow as mainly in and out of New York harbor, with a small Northwestward component. (Note that this data is plotted relative to magnetic north, so the plot must be rotated about 15° counter clockwise to make the directions absolute.)

4. The pressures (Figure 16c) are again in agreement with the predicted tide (tidal constants from Moody, et al., 1984) at the MESA11 site (Figure 16a). The fortnightly modulation of the predicted tide is observed, and the prediction subtracted to get the residual pressures (Figures 16b and 16d). The Paroscientific pressure sensor residuals (Figure 16b) do not show any appreciable low frequency drift, and the typical 10 to 20 cm low-frequency weather forced sea level oscillations are observed. The Druck pressure sensor residuals (Figure 16d) are quite coherent with the Paroscientific pressure sensor, but shows a 0.2 dbar (meter) drift toward greater pressure over the 18 days of the record.

5. The temperature and conductivity records show the effects of the bad cabling. The conductivity record (Figure 17d) and calculated Salinity (Figure 17c) are useless. The temperature record again shows the negative spikes, but the upper bound of the Sea Bird temperature sensor agrees well with the end cap thermistor. This part of the system must be changed to eliminate this problem by replacing the cables and penetrators.

6. The OBS sensors returned good records (Figure 17B), with no really significant suspended sediment events observed. There are small fluctuations in both sensors, and there is a drift toward higher values during the last three days of the record. This is probably due to biofouling of the sensors and will be a major problem in very long term monitoring efforts and will adversely effect the conditional sampling algorithm as discussed below. Further study of this effect with longer records is warranted before long term, quantitative observations can be made.

7. The Druck pressure sensor was burst sampled every day for 3.75 minutes (256) points to obtain surface wave spectra. Figure 20 shows a summary of the 18 spectra obtained from deployment two. The instrumentation caused peak at 0.3 Hz is again dominate, but wave energy in the 10 to 6 second period band is observed to vary with time. More study of this instrumental peak is required as the observed "noise" peak is unacceptably large. Perhaps leaving the power on at all times and using a split battery pack would reduce this error to acceptable levels. The alternative would be to use a frequency multiplier and high speed count the Paroscientific pressures sensor.

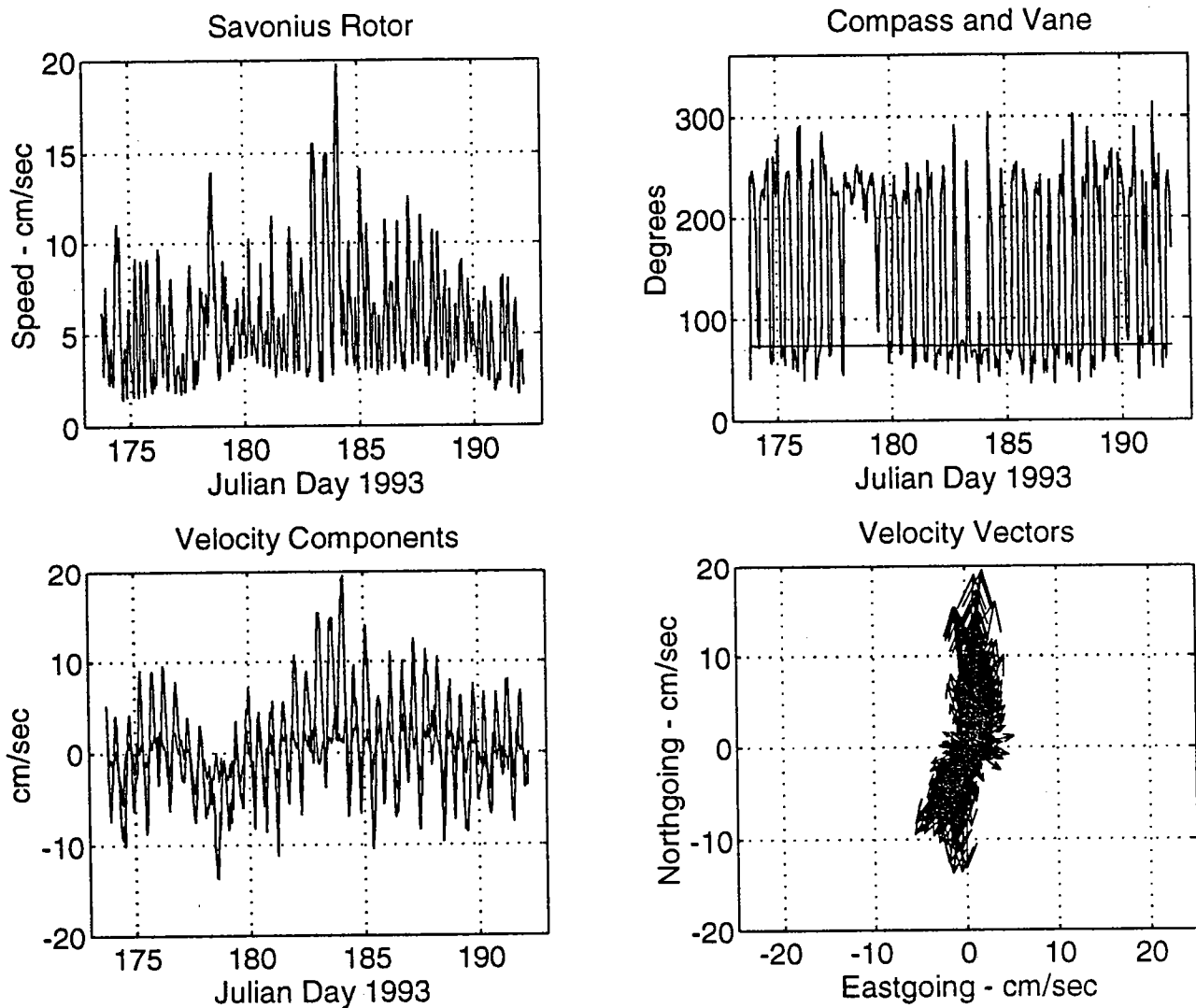

Figure 16. Half-Hourly Velocity averages from deployment two in New York Bight. The Savonius rotor speed (a) shows typical shelf values of velocity. The compass and vane (b) show that the instrument frame did not move on the bottom, and that the current generally switched back and forth from 60° to 240° relative to the frame which had an average orientation of 74° magnetic. The two velocity vectors (c) show mainly a North-South flow in and out of the harbor. A polar plot of the velocity vector (d) relative to magnetic north, shows a mainly North-South oscillatory flow, with a mean component, north and west.

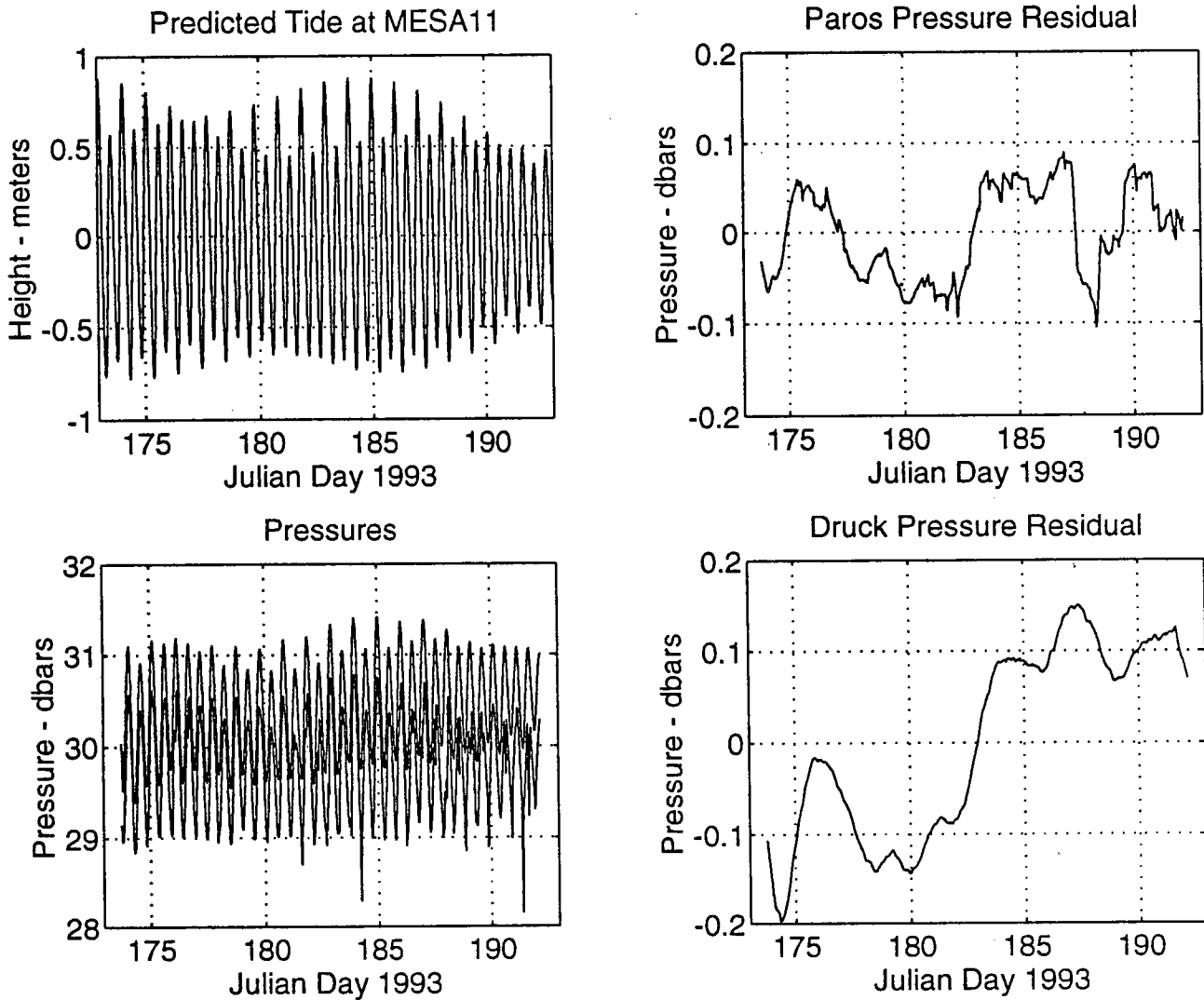

Figure 17. Half Hourly Pressure averages from deployment two in New York Bight. The tidal height (a) was predicted from nearby observations from the MESA program. The fortnightly modulation is seen. The Paroscientific and Druck pressure sensors agree fairly well, except for an offset, and an occasional spike is seen in the Paroscientific sensor due to cabling problems. The low-frequency drift in the Paroscientific sensor (b) is near zero, but the 10 cm weather forced sea surface changes are clearly seen. The Druck sensor residuals (d) show the weather forced signals, but also a slow overall drift toward lower pressures.

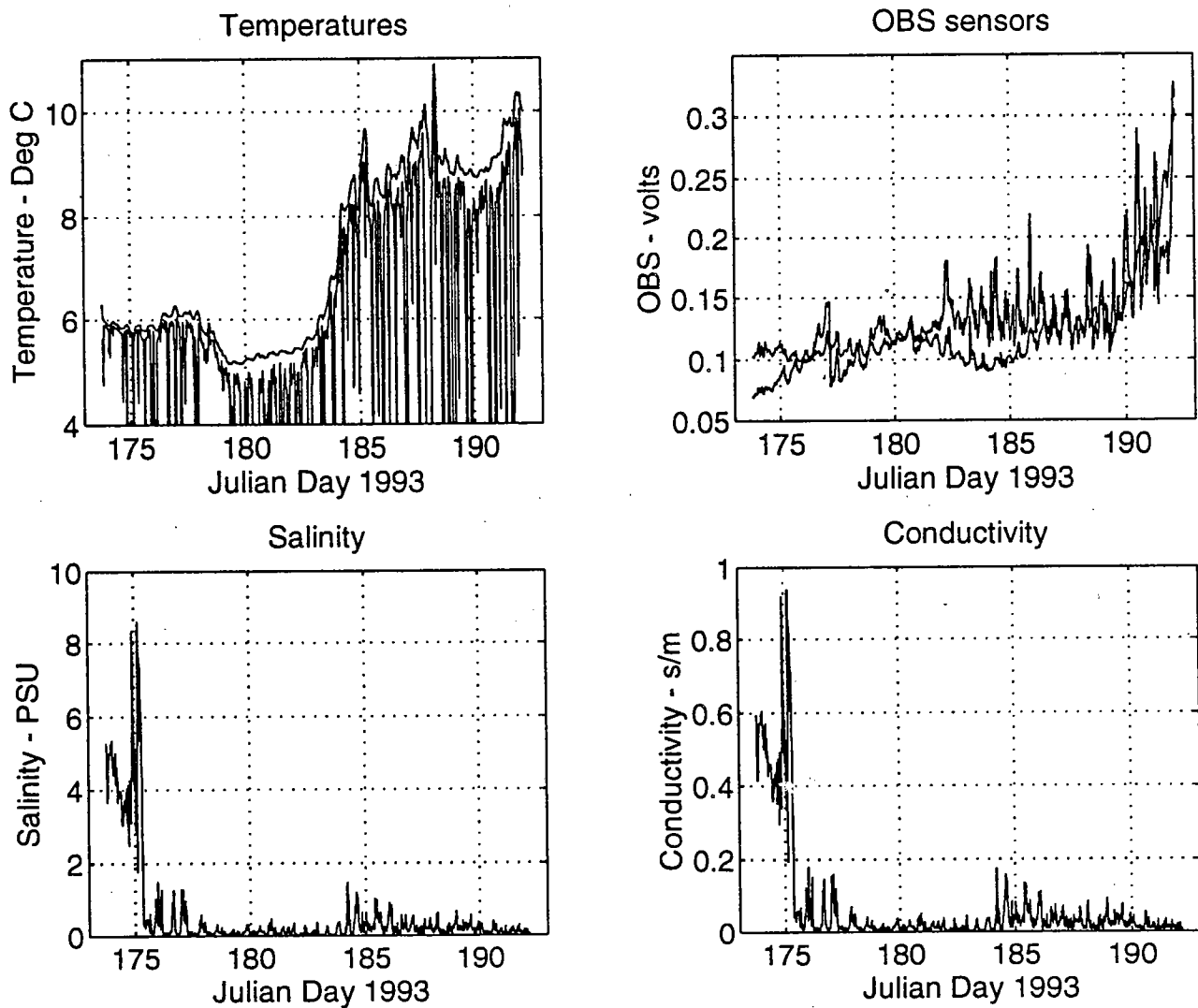

Figure 18. Half Hourly Physical Parameters from deployment two in New York Bight. The temperatures (a) show the cable noise in the Sea Bird sensor. Otherwise there is a slow rise in temperature at the bottom as the summer progresses. The conductivity (d) and salinity (c) are dominated by cable noise and therefore useless. The OBS records (b), show a low volume of suspended sediment with a steady drift toward higher values with time, which is probably associated with biofouling of the sensors.

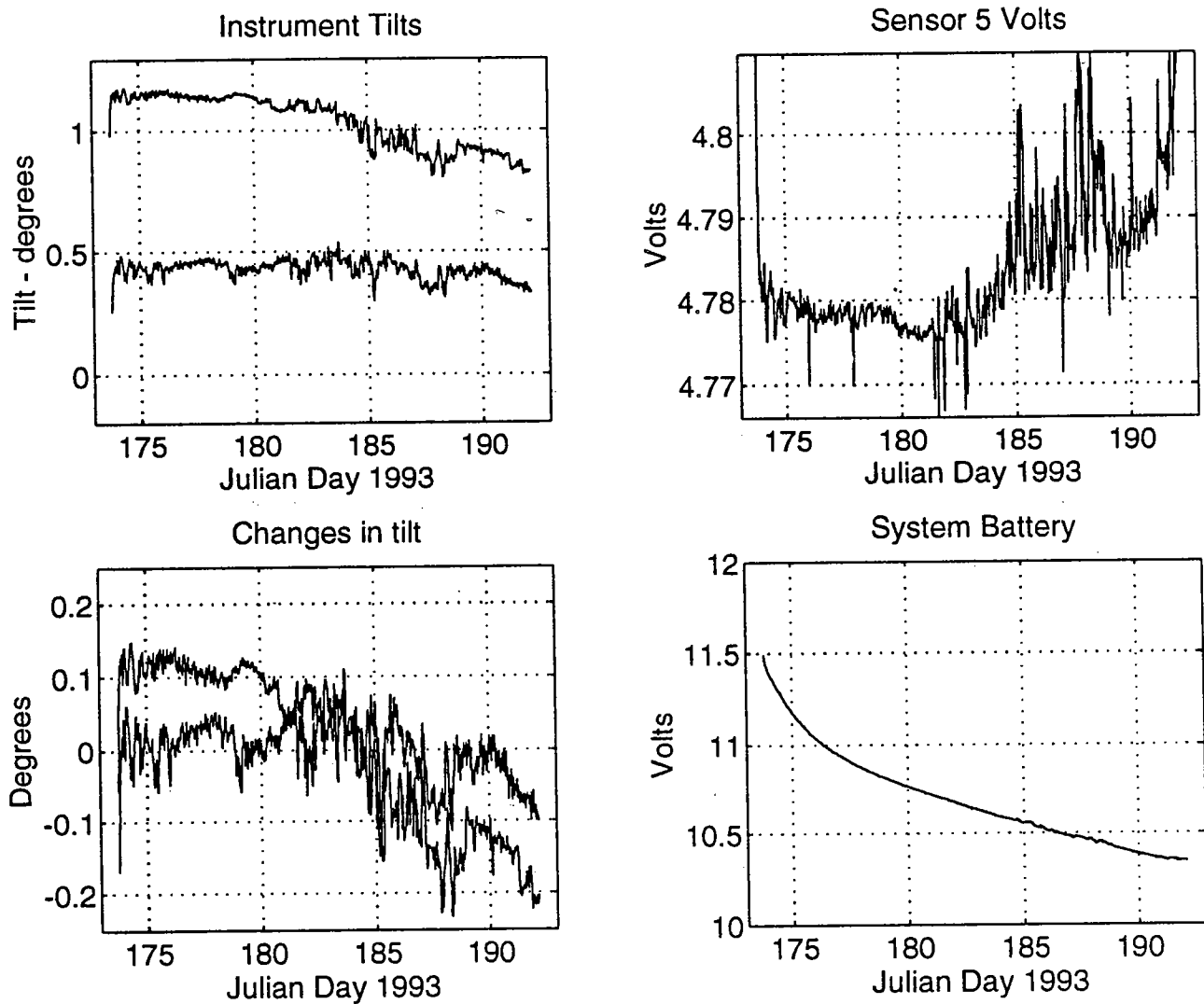

Figure 19. Half Hourly Diagnostics from deployment two in New York Bight. The averaged instrument tilts (a) shows a nearly upright orientation of the current meter. The slow drift of one component (c) shows only 1/3 degree change which could be the instrument settling into the bottom. The regulated sensor voltage (b) shows a systematic drift toward higher voltages, as the system battery (d) discharges and the temperature (Figure 18a) increases.

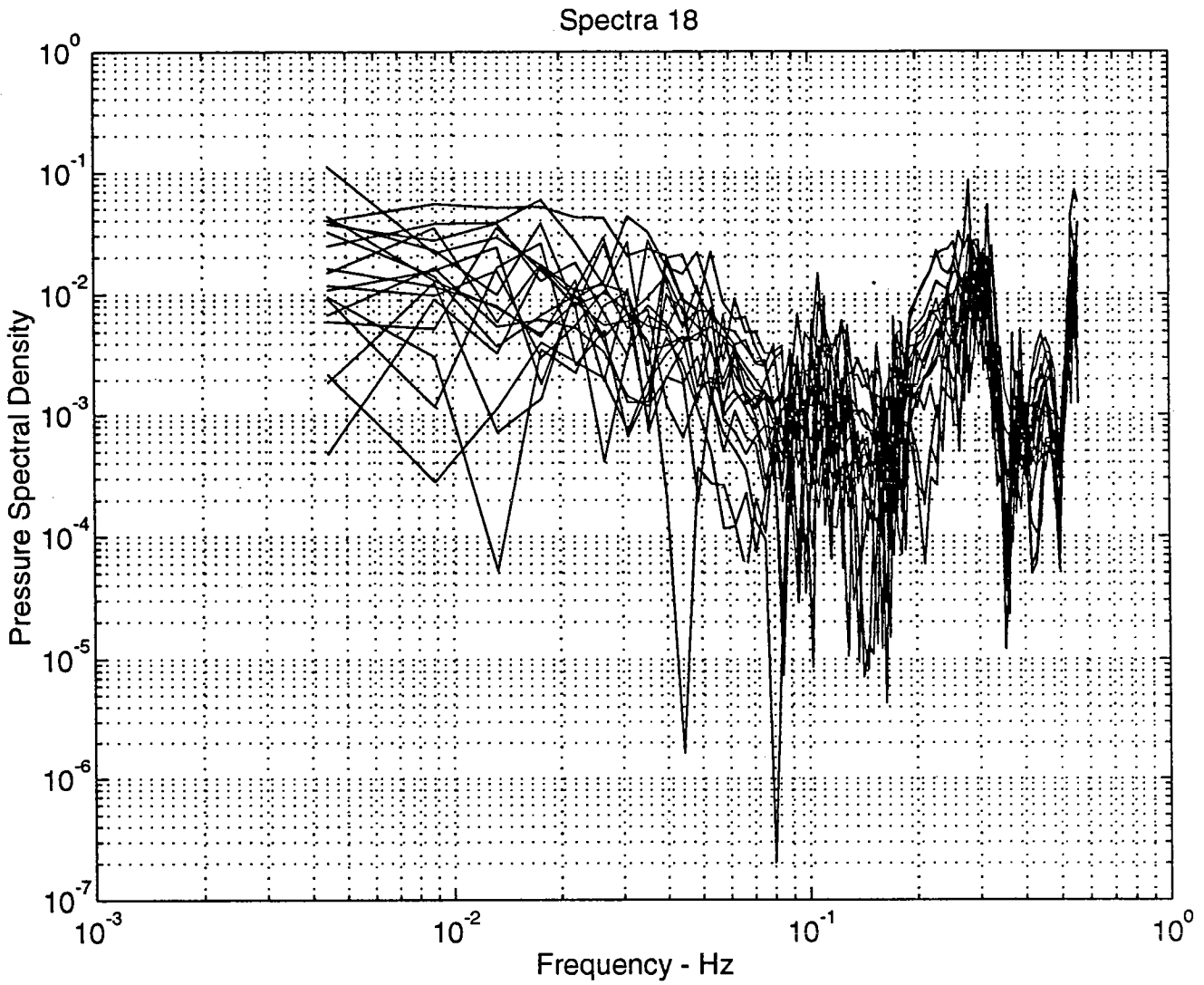

Figure 20. Burst Pressure Spectra from deployment two in New York Bight. A summary of the eighteen burst sampled pressure spectra with no corrections made for attenuation. The results are similar to those shown in Figure 12.

8. For deployment two, the conditional sampling algorithm was initialized with the mask command to allow only OBS triggers to declare an event and initialize recording (see Appendix D). Figure 21 shows the event flag which identifies the events and what triggers them. For deployment two, only OBS triggers, (flag equal to one) were used to trigger events. A total of 146 OBS events were detected as shown in Figure 21 and listed in Table 4A, 4B, 4C, 4D and 4E.

9. The event recording included the speed, pressures, compass and vane in addition to the OBS sensors sampled 3.5156 second intervals. Events with several signatures were observed. The most prevalent were single OBS observations similar to deployment one. Table 4 lists which sensor shows excess signals during the events. Event four on 25 June 1993 (Figure 22) shows four panels of the speed, both pressure sensors, both OBS sensors and the compass direction. The speed record shows the 5.3 cm/sec least count resolution of the 3.5156 second samples with two magnets in the Savonius rotor. The speed is generally low, and not high enough to be associated with a local suspended sediment event. With 8 magnets on the rotor (as on the VACM) the least count uncertainty could be reduced to 1.3 cm/sec. If high frequency wave velocity were important this could be done, but then the choice of current sensor would have to be questioned. The least count resolution on the pressure sensors is 0.01 dbar, and lower than the 0.1 dbar waves seen in most of the event records. The OBS record shows an event in OBS2 only, and no excess signal in OBS1. The compass also shows no signal change with time during the event. This is typical of 50% of the events recorded. Figure 23 (Event 36) is again typical of the single OBS peak, but this time the event is seen in OBS1 only.

10. Another unique signature was seen in the event records which implies suspended sediment events possibly triggered by passing ships. Figure 24 (Event 7) shows a nearly 40 cm/sec current pulse lasting 1/2 minute. The pressure records also show a setdown in sea level of about 0.5 meters during the same time as the velocity pulse. The compass (fixed firmly on the bottom instrument which did not move according to the tilt sensors) shows a -11° rotation for the same 1/2 minute. The OBS1 record at 10 cm shows an increasing signal at the end of the velocity pulse, and about 1 minute later OBS2 at 1 m shows a smaller increase in concentration. The only thing which we can figure would cause the observed compass change is a large passing mass of iron, such as a vessel. This might also cause the decrease in pressure which is directly related to the velocity pulses. Event 10 (Figure 25) shows a similar signature, except now the compass shows a $+12^\circ$ rotation (ship passing on the other side?). The OBS2 sensor shows a smaller rise about 1 minute after OBS1 then about 3 minutes later shows another peak that is not associated with OBS 1, and probably is a fish or whatever causes the first 50% of the events. Event 28 (Figure 26) is another example of this type of event, although not as clean a signature. The currents are not as strong, the pressure depression is not as great, the compass shows less change, and finally the OBSs only show the signal in the 10 cm (OBS1) sensor. Possibly these are due to a smaller vessel or a vessel passing further away.

11. The final event signal is typified by event 137 (Figure 27) where the OBS sensor is high from the start of the event. It is not clear what causes these type of events, but there are a number. Toward the end of the record, the signals were above critical continually because of the rise in the OBS levels, probably caused by fouling. Then the events are 15 minutes long, with 2 hours

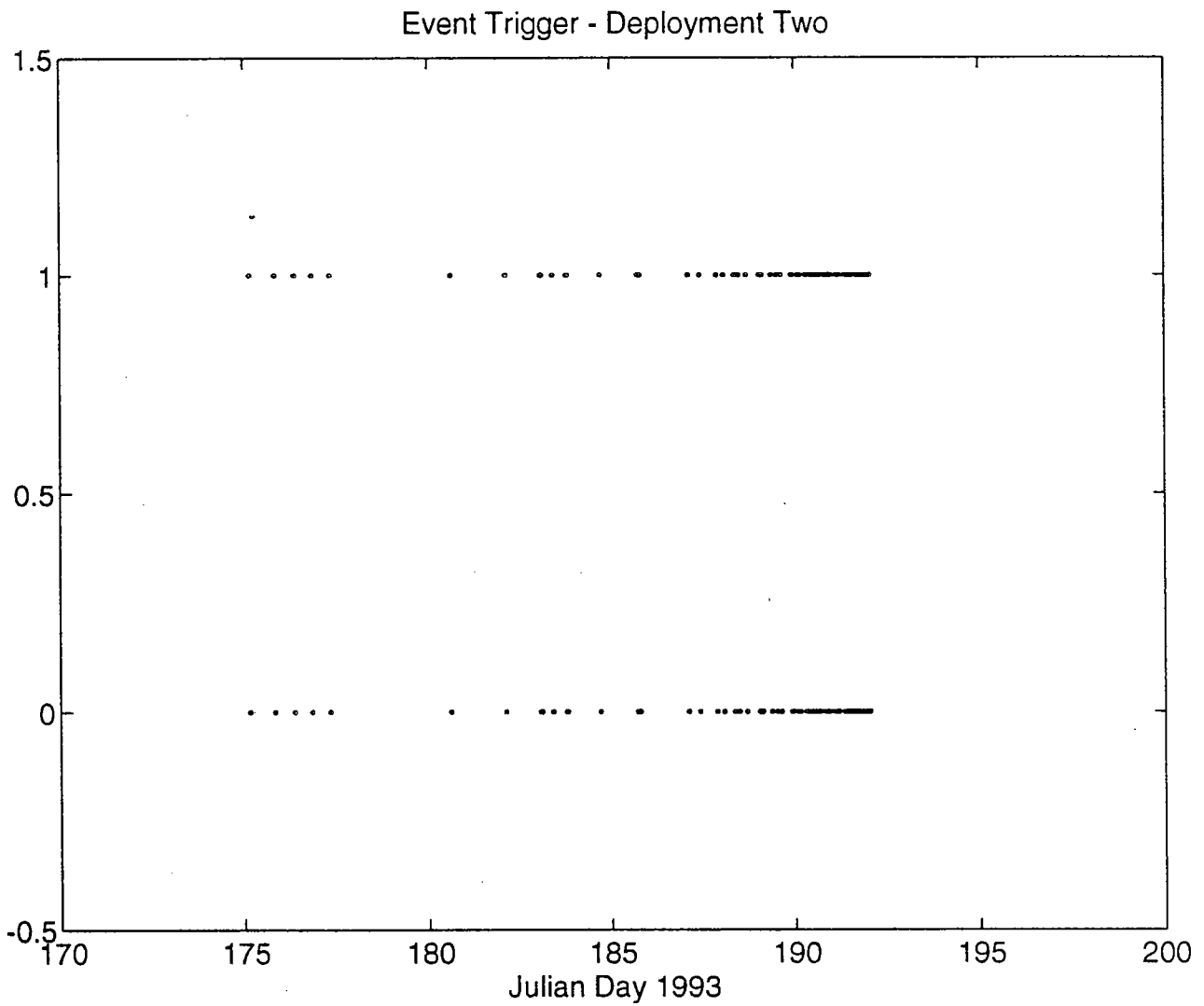

Figure 21. Event Flags for deployment two in New York Bight. Only OBS criticals were allowed to trigger events. There are 146 events identified (see Table 4), but because of the OBS sensor drift, the record become nearly continuous at the end.

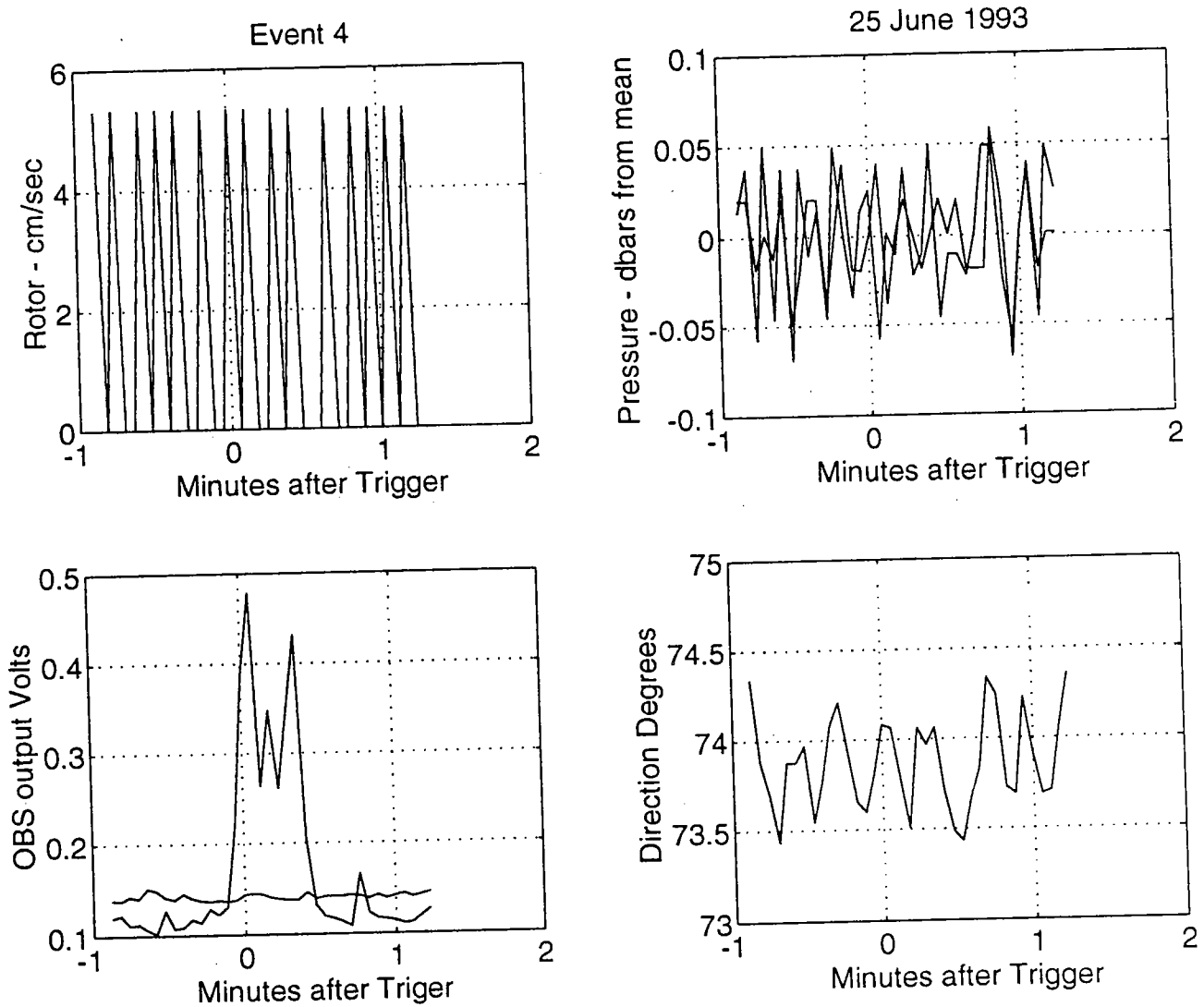

Figure 22. Event 4 deployment two in New York Bight. The speed record (a) is low, and shows the least count in rotor counts at 5.3 cm/sec. The Paroscientific and Druck pressure records (b) show a 0.1 m uncorrected wave field. The single event in OBS2 (c) is typical of 50% of the events. The compass shows a nearly constant 73.9° orientation of the frame.

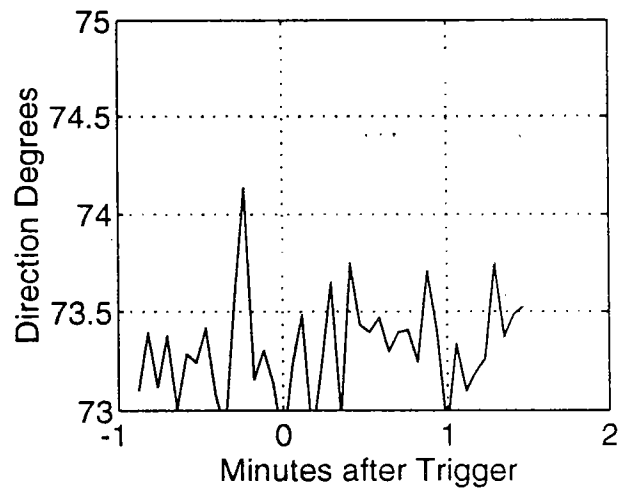
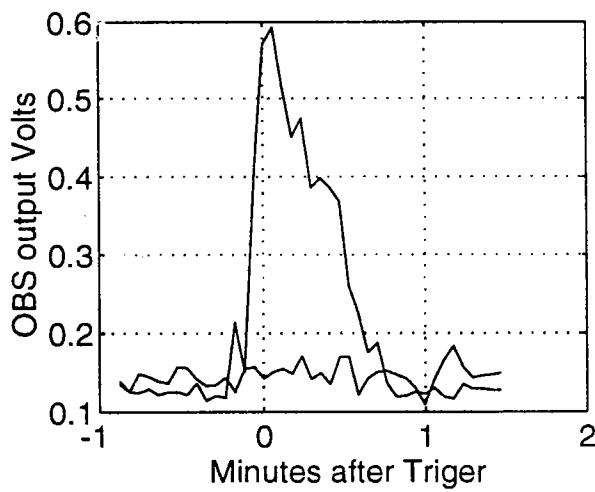
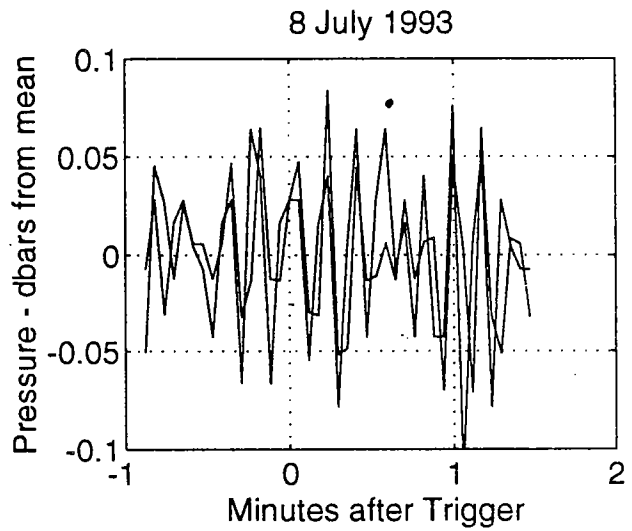
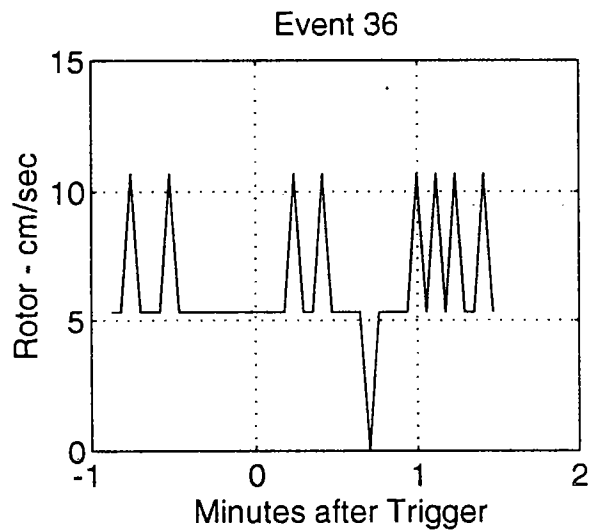

Figure 23. Event 36 deployment two in New York Bight. A single OBS signature event similar to Figure 21, but OBS1 now sees the event.

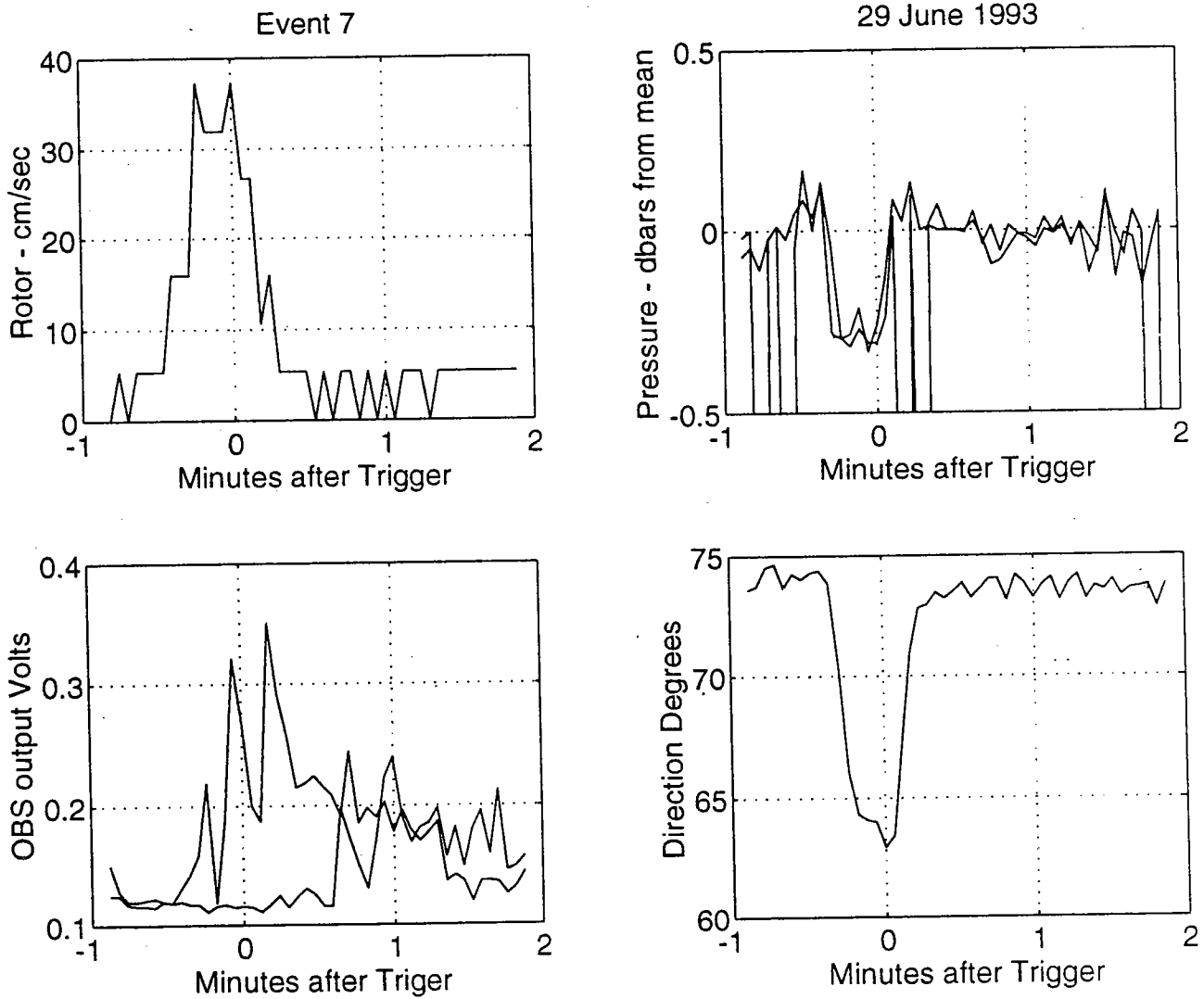

Figure 24. Event 7 deployment two in New York Bight. A more complicated "ship signature" event is seen with a 1/2 minute speed pulse (a) which corresponds to a 1/2 minute 1/2 dbar sea level depression (b) and a -11° apparent rotation of the compass. After the onset of the velocity, OBS1 at 10 cm sees a signal (c), then 1 minute later OBS2 at 1 m sees a smaller signal (c).

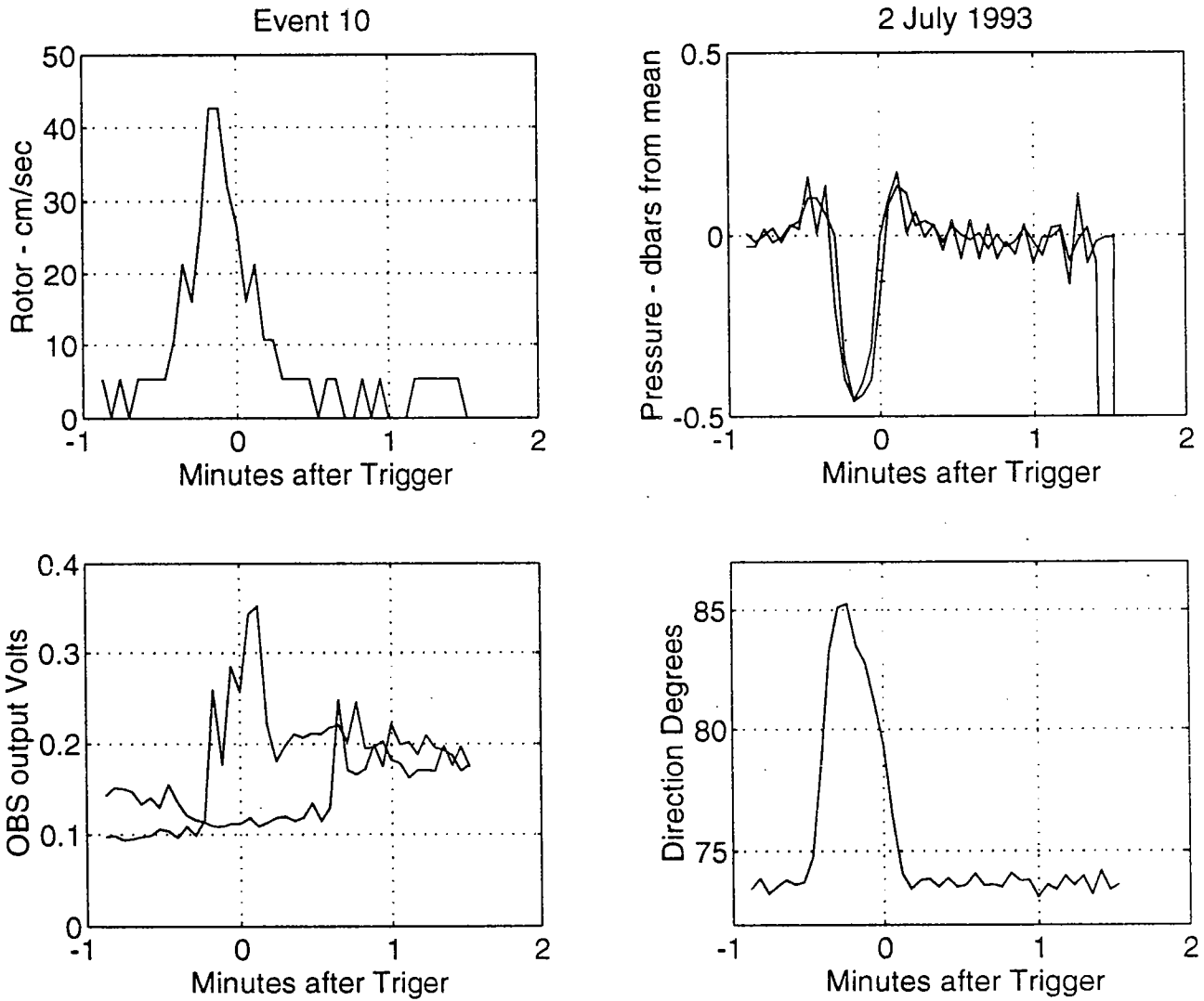

Figure 25. Event 10 deployment two in New York Bight. A "ship signature" event as in Figure 23 except that the compass appears to rotate +12°.

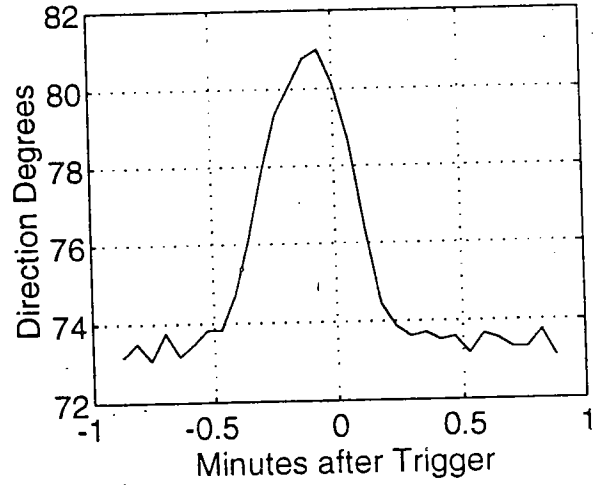
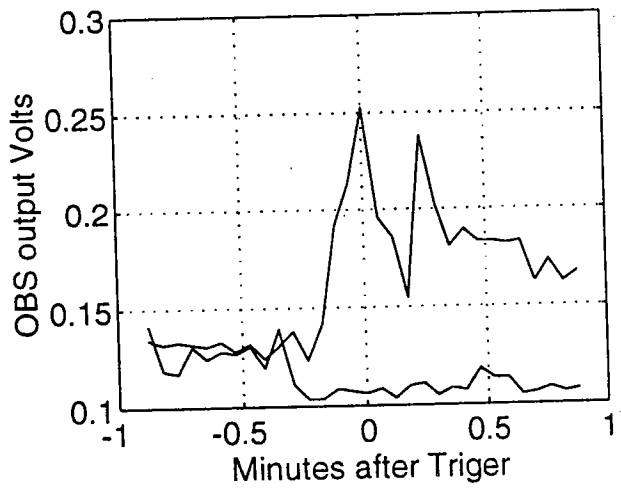
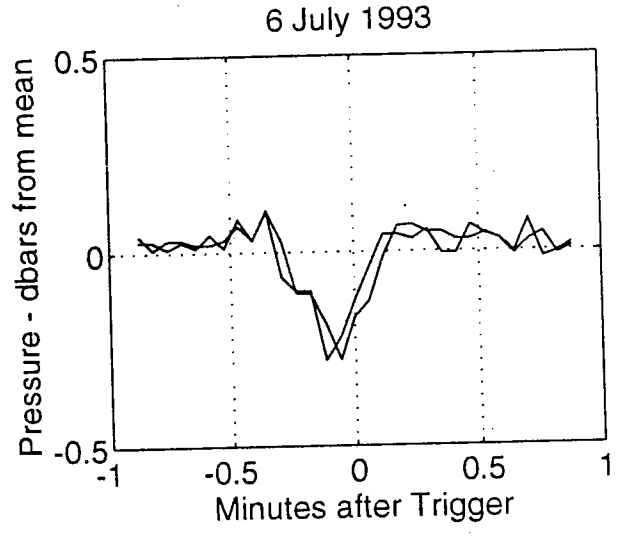
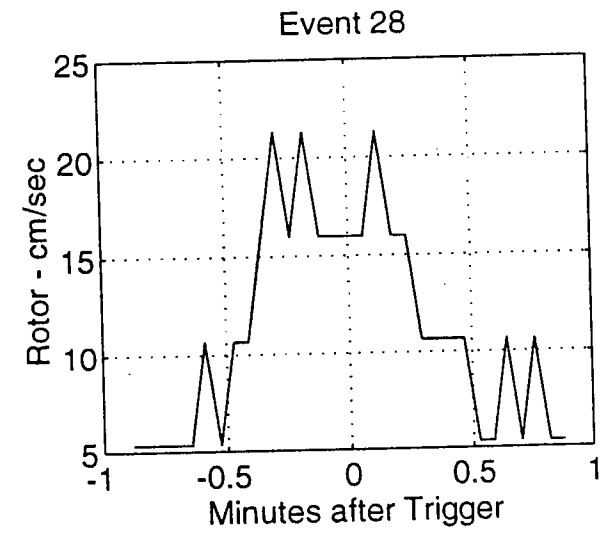

Figure 26. Event 28 deployment two in New York Bight. A "ship signature" event similar to Figures 24 and 25, but with smaller velocity pulse, pressure depression and compass swing. Also the signal is only seen in the 10 cm OBS1.

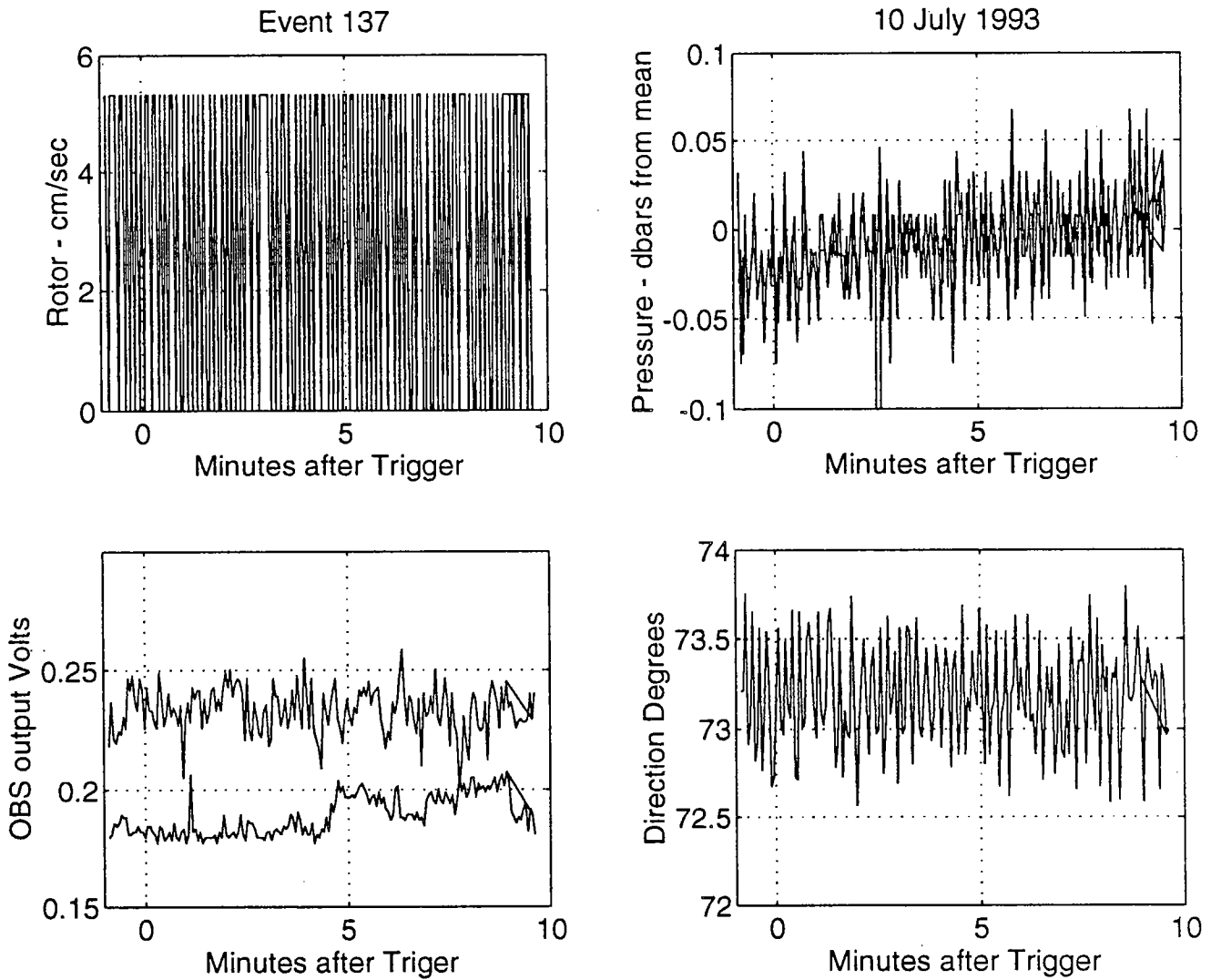

Figure 27 Event 137 deployment two in New York Bight. A "high OBS" signature event which has no velocity, pressure or compass perturbation. One OBS sensor (here OBS1 (c)) is high for a considerable duration.

between events as set during the initialization process (see Table 1 and Appendix D). This lasted until the memory was filled. A fix to this problem is presented in the future directions section where the critical level is allowed to change with time to follow the signal.

12. For the hourly averages of velocity, no count (rotor revolution) is lost, and the least count resolution in velocity or speed drops to 0.0005 cm/sec. Since both the rotor revolutions and the velocity vector averages are recorded, an estimate of the amount of high frequency wave energy filtered out by the vector averaging process can be made. Figure 28 shows this residual velocity signal which is due to surface waves and is energy available to suspend sediments, while the low frequency velocity is responsible for the transport of this sediment. No significant wave activity is seen here.

3.0 Conclusions and Future Directions:

The summer 1993 test of the bottom instrument in New York Bight Apex was the first time that the instrument was configured and deployed as intended. The test showed that the equipment does generally work as planned, and that this sampling technique on a bottom mounted instrument would be a good way to monitor the physical processes and suspended sediment concentrations at a 30 meter site. The instrument showed that it could do the three types of sampling successfully (hourly averages, daily bursts, and events). Problems that were discovered and suggested repairs are:

1. The limited data storage capacity caused loss of much of the potential data which could have been recorded by the instrument. To improve this situations we could
 - A. Increase the critical level for an event to reduce the number of events. This may not have the desired effect if the OBS sensors were to drift. It might be better to allow the critical to change with time. The speed critical should be increased to four times the mean from the start of the deployment. The rotor does not have the drift of the OBS sensors, so a time changing critical is not needed. (See Figure 25 for an example with the deployment two data with the critical level set to 4 times the mean.)
 - B. Have the OBS critical change with time, and be dependent only on the past day's or few hour's observations. This will then allow the critical to drift upwards with the signal as the sensor fouls, and still allow event detection.
 - C. The data storage capacity could be easily increased to 20 to 80 MB by the addition of a Tattletale computer with hard disk storage capacity. This should be a reliable medium as the instrument sitting on the sea floor and after it arrives there is not subject to movement or shock, and is in a rather benign environment as abrupt temperature or humidity changes are concerned. The power requirements could easily be met by a few "D" cells, without decreasing the overall life of the instrument significantly. In fact, we haven't been able to store the information we can collect in the battery life, so data storage is the limiting factor.
2. Cabling/penetrator/connector problems on the pressure, temperature and conductivity sensors caused loss of data. As these cables are old, they should be replaced before the

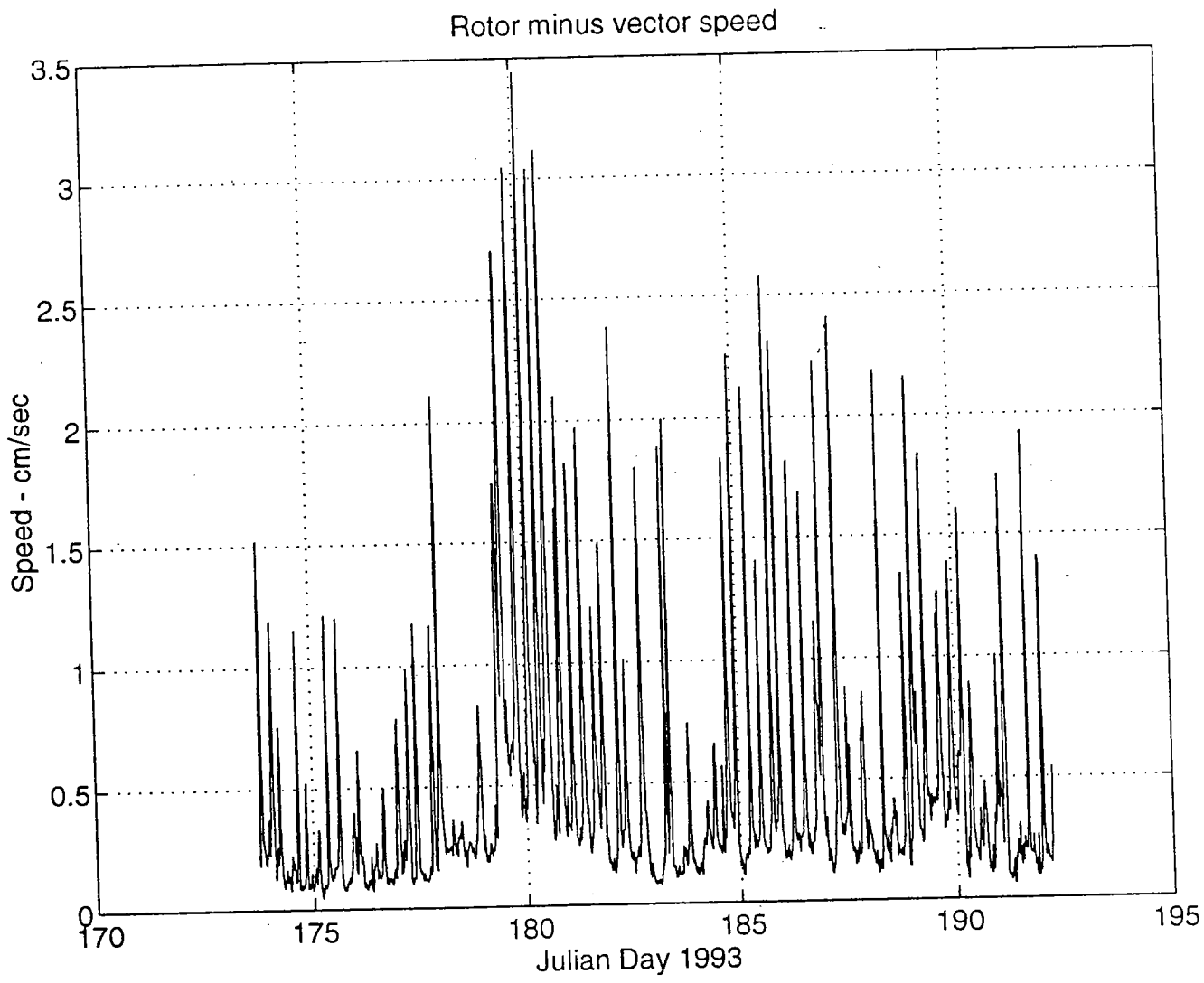

Figure 28. The "Excess Velocity " in wave filed in deployment two in New York Bight. The vector averaging of velocity components removes much of the wave energy from the velocity components, but this energy still remains in the rotor speed record. The difference between the rotor speed, and the speed calculated from the velocity vectors shown here is due to excess wave velocity reaching the bottom.

next deployment. Surprisingly enough, this is the most data loss experienced by this type of problem that we have experienced, and did not expect it after we respliced the cable after the WHOI dock test.

3. As part of a NOAA funded program using an Acoustic BackScatter Sensor (ABSS) this instrument will be refurbished, and redeployed in the fall of 1993 to continue testing. The changes in the conditional sampling algorithm determined by the summer 1993 results, which will allow for the criticals to follow sensor drift, will be implemented and tested.
4. In order to suppress the 0.3 Hz peak in the Druck analog pressure sensor, and improve the reliability of the battery power supply, future deployments will divide the battery into separate sections. In the fall 1993 deployment the battery pack will be divided into three equal portions. This will be done on a spare board which will have the diodes, so that the battery pack can be simpler, and any changes in battery pack grouping can easily be made on the circuit board with jumpers.

In order to show how the suggested OBS criticals should vary with signal, the old criticals and signals are plotted in Figure 29 which show the observed hourly values as the lower solid line, the observed event values as the dots and twice the mean value found by summing the observations from the start of the experiment as the upper solid line. It is seen in Figure 29 (top panel) that on day 192, the critical level and observed signals for OBS1 cross, so that the event detection is on all the time. For OBS2 (bottom panel) this is not so until the very end of the experiment. Nevertheless, this is a problem which prematurely filled the data storage. A suggested fix is to take 0.9995 of the old critical value, and add to it 0.0005 of the of the present observation. This then decays to 1/e of its initial value in 29 hours, so gives the system a 1 day "memory." Figure 30 shows this new critical value for the two cases. It is clear that this improves the situation, as the critical level now follows the drift in OBS 1 (top panel), but does not make the sudden rise seen at the end of OBS2 (bottom panel). Perhaps this is as it should be and we are at the start of a big event, but it seems unlikely. By relaxing the requirement a bit more, and giving the system a 3 hour "memory", the critical follows the observations more closely as shown in Figure 31. This critical would have reduced the number of events from 146 to something like 20, and probably increased the deployment time to about 1 month without increasing the data storage capacity of the instrument.

In order to test the suggested new critical level for velocity, the observations from deployment two are plotted in Figure 32 and similar to deployment one shown in Figure 15. The top panel shows the critical (top solid line) at two times the mean from the start of the experiment. The bottom panel shows the critical (top solid line) as four times the mean, and identifies events 7, 10 and 12, and nearly 28 and 70. Event 10 is strong enough (i.e. reaches 42.7 cm/sec) to trigger an event. To reduce this fixed level a bit, the criteria is changed to four times the mean from the start of the experiment, and greater than or equal to 37.3 cm/sec (7 counts in 3.5156 seconds). This would then have also triggered on event 7 as well as 10.

OBS and Critical Levels

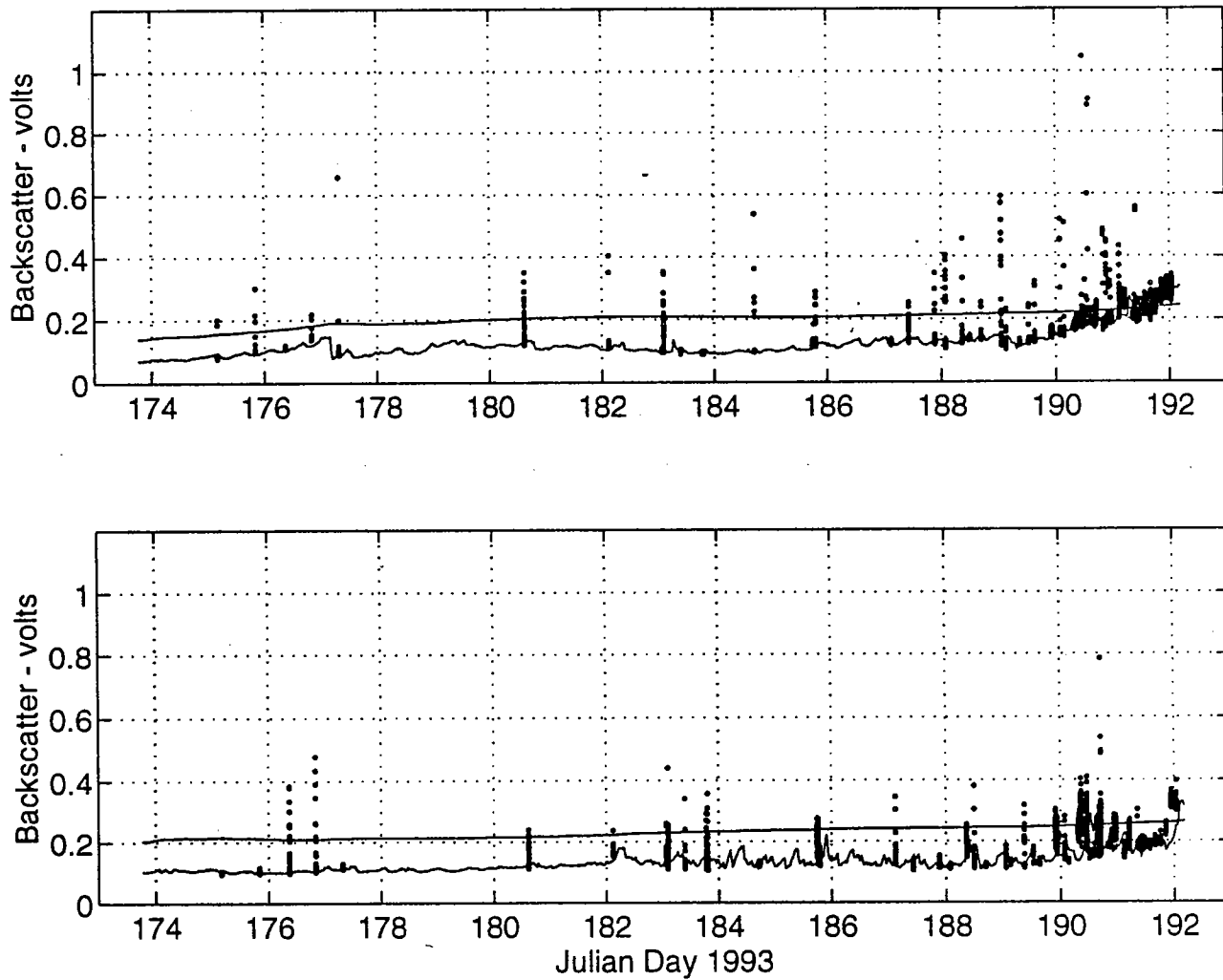

Figure 29. OBS1 at 10 cm height (top panel) and OBS2 at 1 m height (bottom panel), deployment two in New York Bight. The averaged OBS reading (bottom solid line), and critical (top solid line) is plotted with the events (dots). When the dots exceed the critical for two consecutive values, an event is recorded until the values fall below critical for sixteen samples. The drift in the OBS1 sensor at the end turns on the event recording continually.

OBS and Critical Levels

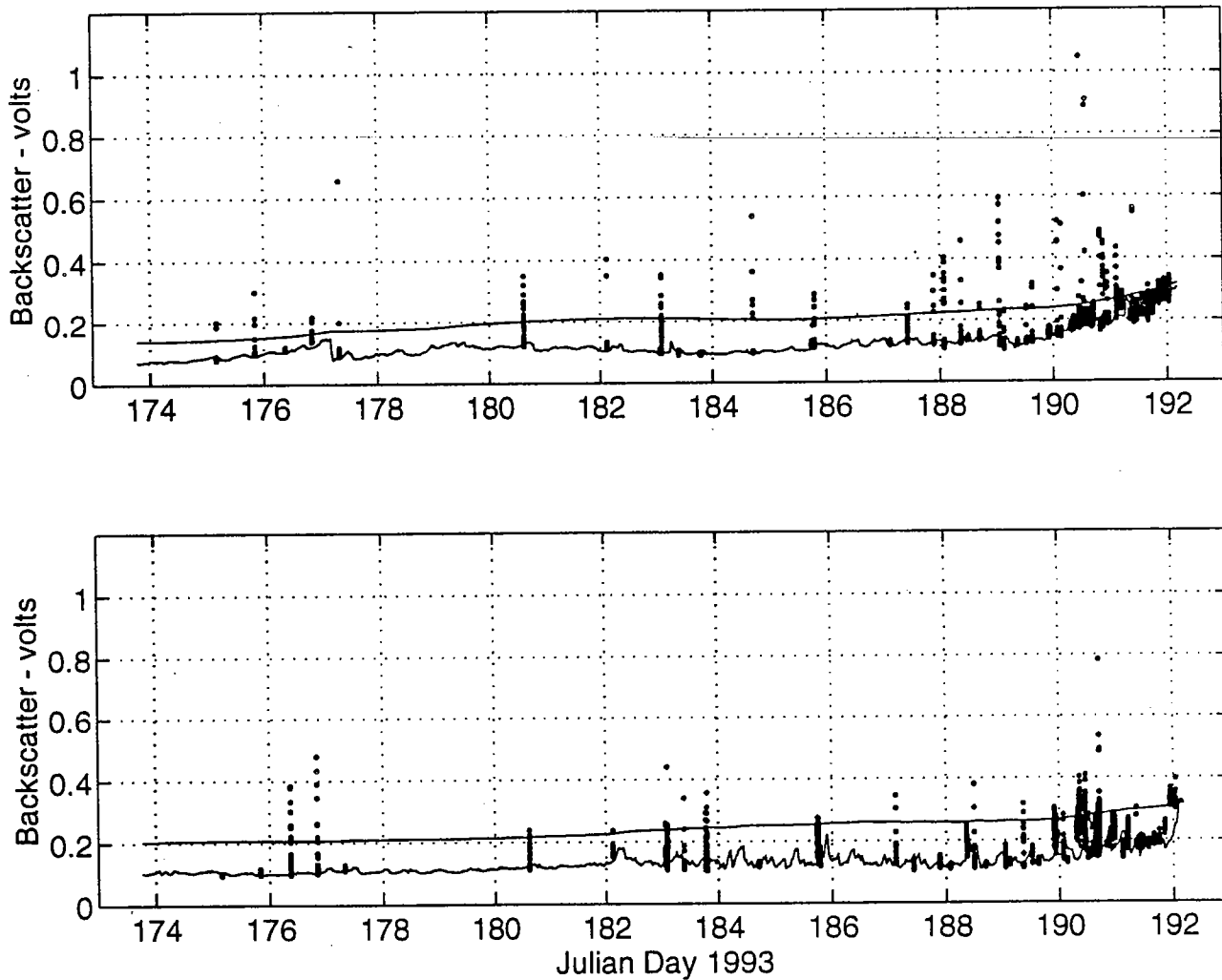

Figure 30. OBS1 at 10 cm height (top panel) and OBS2 at 1 m height (bottom panel), 29 hour critical. Same as Figure 29, except that the critical (top solid line) is determined from a weighted average of past values with a 29 hour $1/e$ memory. This nearly allows for the observed sensor drift near the end of the record.

OBS and Critical Levels

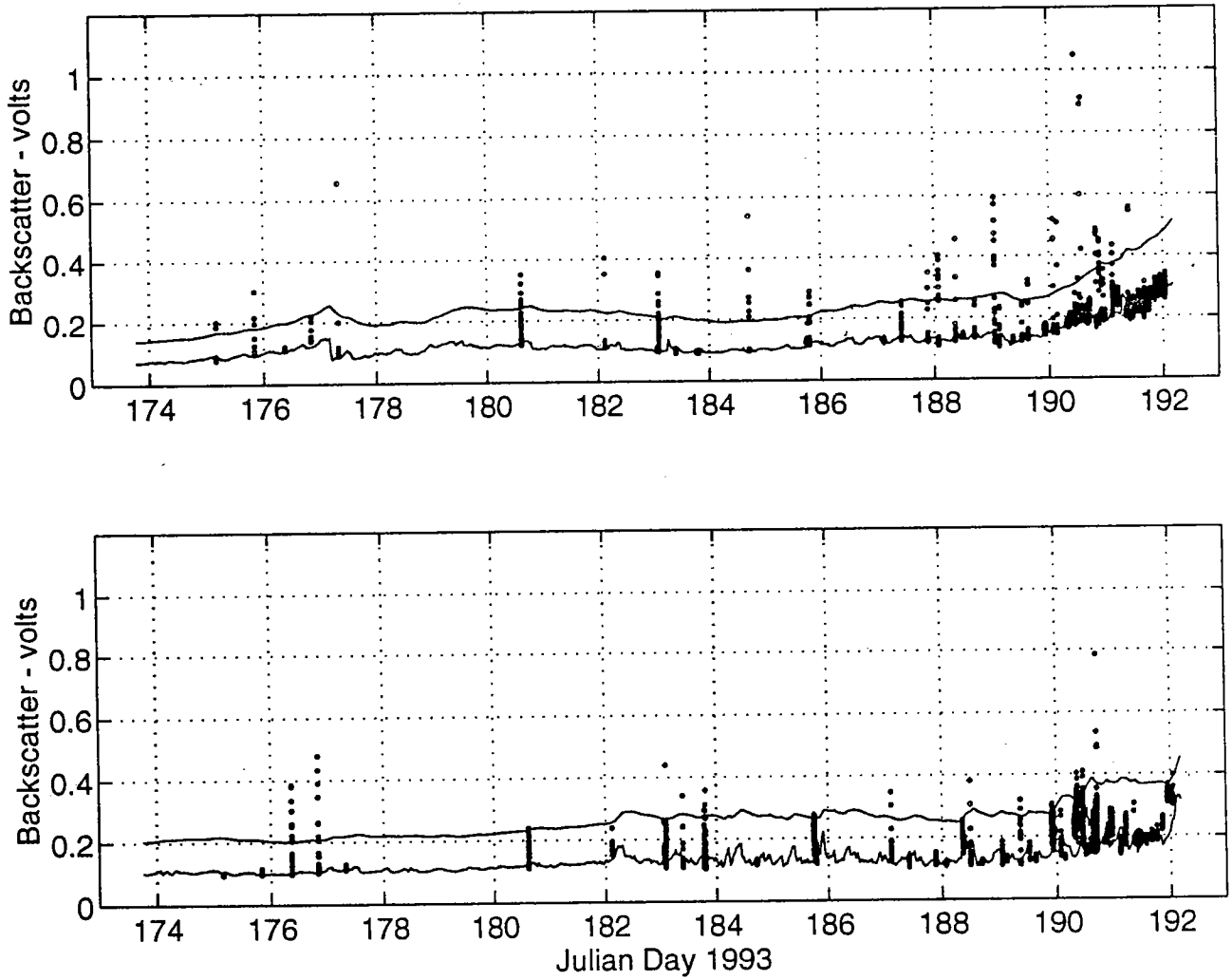

Figure 31. OBS1 at 10 cm height (top panel) and OBS2 at 1 m height (bottom panel), 3 hour critical. Same as Figure 31 except the critical (top solid line) has a 1/e memory of only 3 hours, and now nicely rises with sensor drift.

Speed and Critical Levels

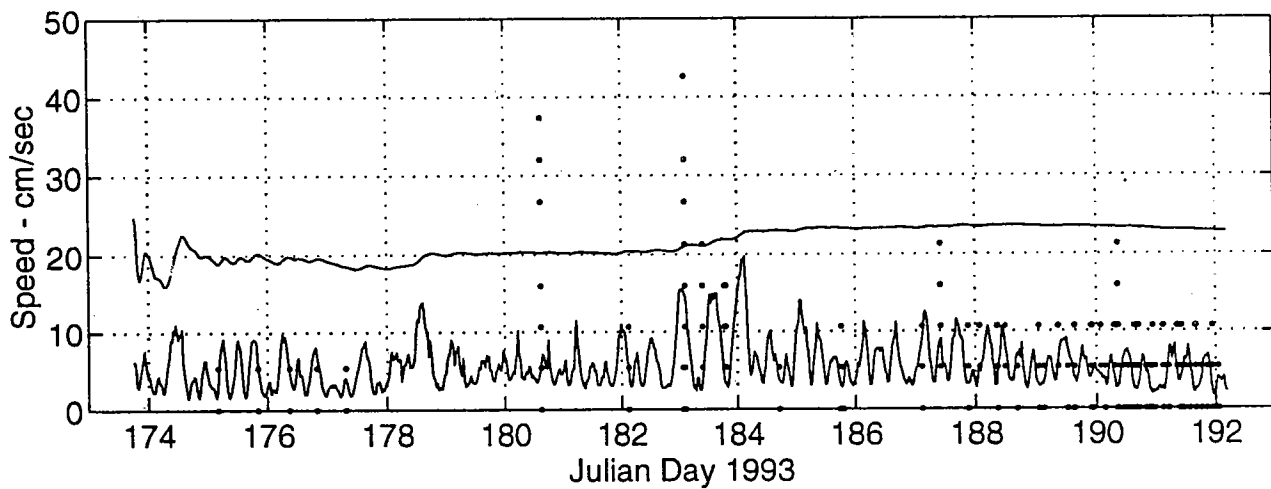
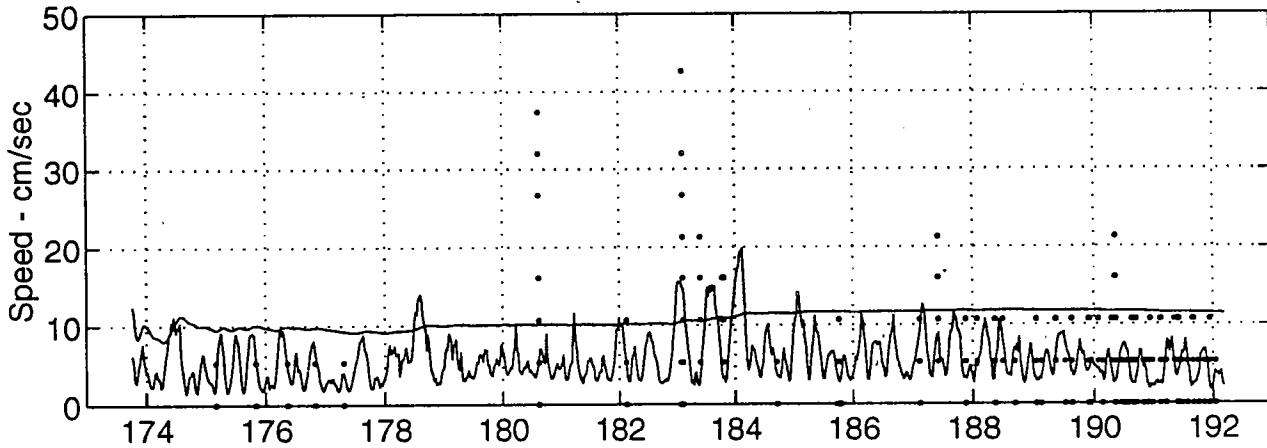

Figure 32. Speed Events from deployment two in New York Bight. Similar to Figure 15, the top panel shows the critical level (top line) as twice the mean record from the start of the record. The bottom line is the hourly averages, and the dots the events samples. In the bottom panel, the event critical level has been increased to four times the mean value, and eliminates all regular tidal currents, but picks up several events as desired.

4.0 References:

Baldwin, K.C., J.D. Irish and H.J. Bokuniewicz, "Real-Time, In Situ Monitoring of Dredge Disposal Sites," *Geotechnical Aspects of Ocean Waste Disposal*, ASTM STP1087, K.R. Demars and R.C. Chaney, Eds., American Society for Testing and Materials, 76-86, 1990;

Brown, W.S., "A Seafloor Data Logger," *Polymode News*, Vol 15, 17 Sept, 1976.

Geyer, W.R., G.B. Gardner, W.S. Brown, J.D. Irish, B. Butman, T. Loder, and R.P. Signell, "Final Report: Physical Oceanographic Investigations of Massachusetts and Cape Cod Bays, for the Massachusetts Bays Program," WHOI Tech. Rept. No. WHOI-92-xxx, 497pp, 1992).

Irish, J.D., W.S. Brown and T.L. Howell, "The Use of Microprocessor Technology for the Sampling of Intermittent Ocean Processes," *Jour. Atm. and Ocean. Tech.*, 1:1, 58-69, 1984.

Irish, J.D., M.P. Woodbury, and E.J. Lacoursiere, "A Bottom-Mounted, Microprocessor-controlled Instrumentation System," *Univ. New Hampshire Mar. Prog. Tech. Rept.*, UNH-MP-T/DR-84-5, 1984.

Irish, J.D., K.C. Baldwin, G.J. Needell, M.A. Martini, and J. Mather, "Testing of a Bottom-Mounted, Intelligent Instrument with Optical Sensors and Real Time Telemetry for Monitoring Dredged Material Disposal Sites," *EOS Tech. Rept. No. EOS-90-TR01*, 74 pp, 1990a.

Irish, J.D., G.J. Needell and K.C. Baldwin, "Dredge Material Disposal Site Monitor: A Bottom Mounted Intelligent Instrument with Packet Radio Telemetry and Environmental and Optical Sensors," *EOS Tech. Rept. No. EOS-90-TR03*, 154 pp, 1990b.

Irish, J.D., K.E. Morey, G.J. Needell and J.D. Wood, "A Current Meter with Intelligent Data System, Environmental Sensors, and Data Telemetry," *IEEE Jour. Ocean Eng.* 16(4), 319- 328, 1991.

Levine, M.D., "Dynamic response of the VACM temperature sensor, *Deep-Sea Res.*, 28A, 1401-1408, 1981.

Mather, J.M., "A Simple and Low-Cost Optical Scattering Sensor for Monitoring Dredge Disposal Sites," *M.S. Thesis*, University of New Hampshire, 75pp, December 1991.

Moody, J.A., B. Butman, R.C. Beardsley, W.S. Brown, P. Daifuku, J.D. Irish, D.A. Mayer, H.O. Mofjeld, B. Petrie, S. Ramp, P. Smith, and W.R. Wright, "Atlas of Tidal Elevation and Current Observations on the Northeast American Continental Shelf and Slope, *U.S. Geological Survey Bulletin* 611, 1984.

Snodgrass, F.E., "Deep-Sea Instrument Capsule," *Science*, 162, 78-87, 1968.

Swift, M.R. and W.S. Brown, "Distribution of Bottom Stress and Tidal Energy Dissipation in a Well-Mixed Estuary," *Estuarine Coastal and Shelf Sci.*, 17, 297-317, 1983.

5.0 Acknowledgments:

This work has been supported by the Department of Commerce - National Oceanic and Atmospheric Administration and the US Army Corps of Engineers, New York District, through a subcontract with Rutgers, through a subcontract with SUNY/Stony Brook R.F. Account #431-8388A. The instrument was initially constructed and tested with previous support by the US Army Corps of Engineers, New York District. The Ocean Process and Analysis Laboratory personnel at the University of New Hampshire participated in the early development. Jerry Needell wrote the initial conditional sampling software, and Jon Wood designed and constructed the mechanical systems. Jeff Mather worked on his MS thesis as part of this program with additional support from the University of New Hampshire's, Ocean Engineering Program. At WHOI Ed Hobart and Ann Martin assisted with conditional sampling revisions, and Pat O'Malley reworked the frame, anchor and assisted in physical operations at WHOI. Captain Bret Zielenski and Mark Wiggins of the R/V ONRUST and various SUNY/Stony Brook graduate students were extremely helpful in these deployments, turnaround and recoveries.

6.0 Appendix A:

First Deployment of GERDA at 30 meter site.

4 May 1993

- 1400 - Loading ONRUST in Jersey City, NJ
- 1500 - Acoustic Release installed and checking
- 1505 - Enable A & B - Command A OK, Command B OK
- 1508 - Release Command - 4 pulses @ 8 sec, then 4 @ 4s - OK
- 1514 - Disable A - 12 pings @ 4s
- 1515 - Disable B - 10 pings @ 4s
- 1520 - Mounting sensors and measuring heights relative to ONRUST deck
 - Paroscientific Pressure S/N 569 @ 29" (0.74m) height
 - Druck Analog Pressure S/N 553421 @ 29.5" (0.75m) height
 - Sea Bird Temperature S/N 490 @ 62" (1.57m) height
 - Sea Bird Conductivity S/N 70 @ 62" (1.57m) height
 - Downing OBS #1 S/N 147 @ 4.13" (0.10m) height
 - Downing OBS #2 S/N 145 @ 39.75" (1.01m) height
- 1620 - GERDA opened and batteries plugged in
 - System Battery Voltage - 12.003 between samples
 - 12.113 in sleep mode

- 11.8706v from A/D during samples
1703 - GERDA closed - (dusted, desiccant added, O-rings cleaned/greased)
1714 - GERDA mounted in bottom frame
Center of CM @ 87" (2.21m) height
Center of Vane @ 79" (2.01m) height
Tilt sensors read 827 & 85D
System Battery reads AD8 => 11.853v
1755 - All sensors plugged in and operating:
Analog Pressure 37F, 3FD, 37D
System Battery ACC, ACC => 11.802v - OK
OBS 91 & 116 for 1 & 2 respectively
Rotor count = 6 in wind
Vane changes from 0 to 2430 in 180°
1808 - EDT initialize for over night test - DT=15 minutes

5 May 1993

0630 - Checking instrument - dumped data to OVERNIT.DMP on EPSON

0640 - Restart

Deployment Parameters:

Sample Interval - 1024 = 1 hour

Burst Interval - 24,576 = 1 day (24 hours)

Burst Length - 128 => 512 points = 7.5 minutes

Event Delay - 2048 = 2 hours

Event Limit - 512 = 1/2 hour

Event Wait - 1024 = 1 hour

MASK = 0000 to use all sensors in conditional sampling for events

Deployment Site:

30 m contour

Just north of Hudson Submarine Canyon head

East of Mud Dump site (3 km NxE)

Inactive Sand Wave field"

about 40° 23.75' N x 73° 49.15' W

0700 EDT - Depart dock for site

TIMES NOW IN UTC

1148 - Narrows bridge - temp 10° C

1230 - at bend in channel, 10 nm to go, 1' swell & light wind chop, 8 Kt from SE

1315 - Waiting for tanker traffic to cross shipping lane - glassy seam, no wind

1340 - Wake up instrument

System Battery = AA5 => 11.635v

Initializing Storage

1345 UTC 5 May 1993 - Start instrument - this is zero time

OBS reading zero?

Press = 370

- 1345 - On station, PDR shows 31m depth
- 1347 - disconnect communication wire
- 1411 - Conductivity cell tube off, rotor and vane foam out
- 1414 - Released - falling, instrument appears to fall sideways with cm horizontal!

Position:

Raytheon Loran-C 4023.52, 7349.25
 Furino Loran-C 4023.63, 7349.55
 GPS - 40° 23.502' N x 73° 49.557' W

- 1420 - Release check
 - A range 60, 61, 63, 65 m
 - B range 68 m
- 1422 - disable B - OK
- 1424 - disable A - OK
- 1425 - Acoustics operation secured
- 1430 - Taking CTD:
 - Bottom Temperature = 5.35°C, Salinity = 31.4 PSU
- 1439 - Second CTD
 - Operations Secured & heading for port

Appendix B:

22 June Recovery and Redeployment of GERDA at 30 meter site

22 June 1993

EDT - Activity

-
- 0704 - Arrive at Fire Island Coast Guard Base & Load R/V ONRUST
 - 0734 - Depart dock for site - distance 30 nm
 - 0810 - Watch and log 13 seconds fast relative to WWV
 - 1048 - On station, proposed LEO30 site
 - 1053 - Sending commands to enable acoustic release
 - 1054 - Sending release command - acknowledged
 - 1055 - Ball sighted on surface
 - 1108 - Instrument on deck & rotor and vane blocked
 - 1119 - Plugged in deck cable & talked with monitor - 33,381 records written
 - Log of final check and stop follows:

RECOVERY.LOG:

DM->s
 Sample int.1024 burst int 24576 len 128 event delay 2048 lim 512 wait 2048
 Real-Time Monitor OFF

Recorder ON
Format Selected Computer

Storage Position	Used	Total	Left
Bytes 00524288	00523500	00524288	00000788
Records 33381	33381	-32768	-64923
File 0	0	--	

DM->r

3.5 sec. record - time 132694
nevent 00 evdly 1 evlim 512
a/d 36F 7F9 86E B85 E0E F54 945 6D 0
ctd 206560A4D021F4B7D24016A0
rotor 0 comp. 2949 vane 3598

DM->r

3.5 sec. record - time 132701
nevent 00 evdly 1 evlim 512
a/d 36E 7DC 87E B35 DF9 F52 943 6A C8
ctd 2065D0A55021F4B7D04016A0
rotor 0 comp. 2869 vane 3577

DM->a

time = 132095
samples 1024 type 0
a/d data 3521157 3066364 1284785 2312744 2177674 4005541 2427072 239018 414962
squares 1964185915 55877526 168997198
rotor 253 comp 2261 vane 2476 east -18920 north 36932
ctd endt 855637 press 140744577 temp 24436339 cond 119224

DM->c

time 132711
evmask 0000 nsamp 132695
pmean 3385.240554 pdstd 42.089533 spmean .373465
obsmeans 168.137860 325.620722

DM->r

3.5 sec. record - time 132753
nevent 00 evdly 1 evlim 512
a/d 36C 81A 858 B5D E04 F48 944 71 0
ctd 206910A84021F4C7D0101500
rotor 0 comp. 2909 vane 3588

h
clock stopped

DM->s
Sample int.1024 burst int 24576 len 128 event delay 2048 lim 512 wait 2048
Real-Time Monitor OFF
Recorder ON
Format Selected Computer

Storage Position	Used	Total	Left
Bytes 00524288	00523500	00524288	00000788
Records 33381	33381	~32768	~64923
File 0	0	--	

11:23:30 (-13s) time = 132,753

NOTE: For elapsed time of 48 d, 1 h, 38 m, 30 s; count = 1,181,329. Since our hardware counter is 20 bits, or 1,048,576, it should overflow once. Therefore, 1,048,574 + 132,753 = 1,181,329. Our observed and predicted count are the same, and the basic time kept by the hardware clock is correct.

- 1124 - clock stopped - dumping data to LEO30.DMP
- 1138 - dump complete & backing up file on floppy disk under LEO30.DMP
- 1230 - GERDA removed from frame and opened in ONRUST lab
- 1245 - Restart and check of system on old batteries

TURNAROUND.LOG:

DM->s
Sample int.256 burst int 1024 len 128 event delay 128 lim 256 wait 256
Real-Time Monitor OFF
Recorder ON
Format Selected Computer

Storage Position	Used	Total	Left
Bytes 00524288	00524288	00524288	00000000
Records 33381	33381	~32768	~64923
File 0	0	--	

DM->N
continue ?Y:M:Searching ...
:S:END OF STORAGE
Message length must be between 5 and 80 characters.
Hit <RETURN> key to terminate.
LLAABBOORRAATTOORRY RREESSTTAARRTT TTEESSTT

:S:END OF STORAGE

Sample int. ? 1166
burst int. ? 11002244
burst length ? 44
event delay ? 00
event limit ? 00
event wait ? 00

press g G
DM->÷? Floating point error FDZ

DM->5
3.5 sec. record - time 3
nevent 00 evdly 128 evlim 256
a/d 0 BBE A9C A74 D68 F68 965 0 0
ctd 000030C8900000000000000000
rotor 0 comp. 2676 vane 3432

time = 15
avg err time = 31
avg err time = 47
avg err

DM->A
time = 47
samples 16 type 0
a/d data 0 18663 48054 43253 52880 63097 38470 0 0
squares 0 0 0
rotor 0 comp 2711 vane 3308 east 0 north 0
ctd endt 51226 press 0 temp 0 cond 0
time = 63

avg err
DM->R

3.5 sec. record - time 66
nevent 00 evdly 78 evlim 256
a/d 0 48F BBA A92 CF5 F67 965 0 0
ctd 000420C7C00000000000000000
rotor 0 comp. 2706 vane 3317

DM->P
continue ?Y Are you SURE (Y/N) ? YY
Initializing Storage ... Done !÷
:M: Searching ...
:D: END OF DATA
Message length must be between 5 and 80 characters.

Hit <RETURN> key to terminate.
LLAABBOOR÷AATTOORRY TTEESSTT WWIITTHH OOLLDD
BBAATTTTEERRIIEESS

:D:END OF DATA
Sample int. ? 1166
burst int. ? 11002244
burst length ? 44
event delay ?
event limit ?
event wait ?

press g G

DM->R

3.5 sec. record - time 1
nevent 00 evdly 128 evlim 256
a/d 0 486 BB9 AAD CFC F68 966 0 0
ctd 000010C79000000000000000
rotor 0 comp. 2733 vane 3324
time = 15
time = 31
time = 47
time = 63

DM->R

3.5 sec. record - time 10
nevent 00 evdly 256 evlim 256
a/d 0 489 BC0 A6F B F69 A91 0 0
ctd 0000A0C74000000000000000
rotor 0 comp. 2671 vane 11

DM->r

3.5 sec. record - time 79
nevent 00 evdly 193 evlim 256
a/d 0 48C BBF A1C F61 F69 A98 0 0
ctd 0004F0C85000000000000000
rotor 0 comp. 2588 vane 3937

P

continue ?Y Are you SURE (Y/N) ? YY

Initializing Storage ... Done !÷

:M:Searching ...

:D:END OF DATA

Message length must be between 5 and 80 characters.

Hit <RETURN> key to terminate.
LLAABBOORRAATTO÷RRYY TTEESSTT OONN NNE÷WW
BBAATTTTEERRIIEESS

:D:END OF DATA
Sample int. ? 1166
burst int. ? 11002244
burst length ? 44
event delay ?
event limit ?
event wait ?

press g G

DM->RR
3.5 sec. record - time 1
nevent 00 evdly 128 evlim 256
a/d 0 48F BBA A1A F58 F6B A99 0 0
ctd 000010C85000000000000000
rotor 0 comp. 2586 vane 3928
time = 15
time = 31
time = 47
time = 63
time = 79
time = 95
time = 111
time = 127
time = 143
time = 159
time = 175
time = 191
trigger 4
trigger 0
time = 207

DM->R
3.5 sec. record - time 360
nevent 00 evdly 1 evlim 256
a/d 0 807 853 3C5 6AE F73 A9B 0 0
ctd 001680D02000000000000000
rotor 0 comp. 965 vane 1710
time = 367
time = 383
time = 399

time = 415
time = 431
time = 447
time = 463

DM->R

3.5 sec. record - time 477
nevent 00 evdly 1 evlim 256
a/d 0 7FE 869 410 6B3 F6F A99 0 0
ctd 001DD0D1B021F5084C932940
rotor 0 comp. 1040 vane 1715
time = 479
trigger 4
time = 495
trigger 0
trigger 4
trigger 0
time = 511
time = 527
trigger 4
trigger 0

DM->R

3.5 sec. record - time 539
nevent 20 evdly 1 evlim 245
a/d 378 81A 848 3D9 6B7 F7E A89 0 0
ctd 0021B0D28021F508502325D0
rotor 0 comp. 985 vane 1719
X

mask 00006600

mask 0060
time = 543
trigger 1
trigger 0
time = 559
time = 575
time = 591
time = 607
time = 623
time = 639
trigger 1
trigger 0
time = 655

trigger 1
trigger 0
trigger 1
trigger 0
trigger 1
trigger 0
time = 671
trigger 1
time = 687
trigger 0
time = 703
trigger 1
trigger 0
time = 719
trigger 1
trigger 0
time = 735

DM->S

Sample int.16 burst int 1024 len 4 event delay 128 lim 256 wait 0
Real-Time Monitor OFF
Recorder ON
Format Selected Computer

Storage Position	Used	Total	Left
Bytes 00017611	00017591	00524288	00506697
Records 929	929	~29127	~28198
File 0	0	--	

DM->H

clock stopped

1247 - Installed new battery pack - system says battery is 11.55 v
1306 - Instrument closed and putting in frame

START.LOG:

DM->S

Sample int.16 burst int 1024 len 4 event delay 128 lim 256 wait 0
Real-Time Monitor OFF
Recorder OFF
Format Selected Computer

Storage Position	Used	Total	Left
------------------	------	-------	------

Bytes 00017657 00017637 00524288 00506651
Records 932 932 ~29127 ~28195
File 0 0 --

DM->P

continue ?Y Are you SURE (Y/N) ? YY

Initializing Storage ... Done !+

:M: Searching ...

:D: END OF DATA

Message length must be between 5 and 80 characters.

Hit <RETURN> key to terminate.

LLEEOO3300 -- 2222 JJUUNNEE 9933 -- 1133::4400 EEDDTT

:D: END OF DATA

Sample int. ? 551122

burst int. ? 2244557766

burst length ? 6644

event delay ? 22004488

event limit ? 225566

event wait ? 22004488

press g

press g

press g

press g

press g

press g G

DM->R

3.5 sec. record - time 0

nevent 00 evdly 2048 evlim 256

a/d 374 81D 841 413 6CD F92 A89 0 0

ctd 000000FC0911C9775E74BA10

rotor 0 comp. 1043 vane 1741

time 0

evmask 0060 nsamp 0

pmean 0.000000 pdstd 0.000000 spmean 0.000000

obsmeans 0.000000 0.000000

DM->R

3.5 sec. record - time 8

nevent 00 evdly 2048 evlim 256

a/d 375 828 849 446 6BD F85 A89 0 0

ctd 000080D35021F5084EB33700

rotor 0 comp. 1094 vane 1725

DM->

3.5 sec. record - time 22
nevent 00 evdly 2042 evlim 256
a/d 376 849 842 426 6BA F85 A89 0 9F
ctd 000160D37021F5184EE32D00
rotor 0 comp. 1062 vane 1722

DM->R

3.5 sec. record - time 37
nevent 00 evdly 2027 evlim 256
a/d 377 821 853 456 6B9 F7A A88 0 0
ctd 000250D39021F5084DB32260
rotor 0 comp. 1110 vane 1721

DM-R>

3.5 sec. record - time 40
nevent 00 evdly 2024 evlim 256
a/d 376 819 84E 466 6B9 F86 A89 0 0
ctd 000280D39021F5084EB31F60
rotor 0 comp. 1126 vane 1721

DM->

3.5 sec. record - time 51
nevent 00 evdly 2013 evlim 256
a/d 375 803 850 283 6B7 F84 A88 A93 0
ctd 000330D3A021F50851131C50
rotor 0 comp. 643 vane 1719

DM->R

3.5 sec. record - time 106
nevent 00 evdly 1958 evlim 256
a/d 377 82D 83B CE 6D2 F87 A87 AB2 ED
ctd 0006A0D3F021F518B4231560
rotor 0 comp. 206 vane 1746

DM->C

time 107
evmask 0060 nsamp 91
pmean 886.791229 pdstd 1.175824 spmean 0.000000
obsmeans 1871.791458 120.593416

DM->C

time 118
evmask 0060 nsamp 102

pmean 886.872577 pdstd 1.166667 spmean 0.000000
obsmeans 1808.676528 257.696104

DM->R

3.5 sec. record - time 120
nevent 00 evdly 1944 evlim 256
a/d 377 824 846 DD 6CD F86 A89 4B AFA
ctd 000780D43021F508B66313E0
rotor 0 comp. 221 vane 1741

S

Sample int.512 burst int 24576 len 64 event delay 2048 lim 256 wait 2048
Real-Time Monitor OFF
Recorder ON
Format Selected Computer

Storage Position	Used	Total	Left
Bytes 00000043	00000043	00524288	00524245
Records 1	1	~12192	~12191
File 0	0	--	

13:40:14 - pressed "G" to start system (Note - 1 sec late)
1400 - Start deployment
1401 - Release from ship
1403 - Acoustic Slant Range 45 m
1403 - Disable A
1404 - Disable B
1415 - Head for home
1720 - Arrive at Fire Island Coast Guard Station

Appendix C:

28 July 1993 Recovery at 30 meter site

EDT

1230 - Arrive Newport Marina, Jersey City, NJ
1330 - R/V ONRUST tied to dock and unloading
1340 - Depart dock for site
 running against tide, speed about 1 kt slower
1530 - Testing acoustic command unit - pings
1400 - Wind up to 15 kts from SW - whitecaps
1640 - On station

1641 - Enable Release Commands A & B - range 440 meters
1643 - Command a Release, Acknowledge - 3 @ 8s & 6 @ 4s
1644 - Range 419 meters
1646 - Release Commanded Again - Acknowledge - range 406 meters
1653 - Range 414, 419 meters
1655 - Moving west
1656 - Range 310 meters - sighted ball on surface
1700 - Recovery position:
 40° 23.54' N x 73° 49.24' W
1707 - Instrument on deck and secured
1712 - 29971 records, memory full - appears to be operating OK

DM->s

Sample int.512 burst int 24576 len 64 event delay 2048 lim 256 wait 2048
Real-Time Monitor OFF
Recorder ON
Format Selected Computer

Records 29971 29971 ~30840 ~ 869
File 0 0 --

DM->R

3.5 sec. record - time 888367
nevent 00 evdly 273 evlim 256
a/d 372 7D6 885 EE7 826 F55 913 40 E4
ctd D8E2F0C38021F4A035401640
rotor 0 comp. 3815 vane 2086

DM->A

time = 888319
samples 512 type 0
a/d data 1457541 1071645 1068511 504123 613286 2006997 1189699 89445 246327
squares 1303016421 18019279 142049037
rotor 2158 comp 3545 vane 2089 east -66633 north -75274
ctd endt 773323 press 70566043 temp 13329025 cond 447402

DM->C

time 888370
evmask 0060 nsamp 888354
pmean 3416.325092 pdstd 27.848367 spmean 1.134649
obsmeans 152.914681 256.064057

DM->R

3.5 sec. record - time 888377
nevent 00 evdly 263 evlim 256

a/d 371 831 84A DFB 826 F51 916 3C 12E
ctd D8E390C3F021F49855001080
rotor 0 comp. 3579 vane 2086

h
clock stopped

17:14:58 wrote sample 888377 & clock stopped

1715 - dumping data to "SECOND.DMP"

1720 - taking cores - got gravel, suggested move back to recovery position - got good fines core

1720 - Survey of Instrument on deck:

Biological Growth on top of balls
Release Clean, zinc black and smaller in size
Slight barnacle growth on anchor
Sediment on frame and in balls

Sensors:

Paros Pressure - goop all over, sediment on top
Druck - minor corrosion around bolts on end cap
OBSs - Slight "stuff" on top one, bottom one has sediment and biological growth
WBOT290 - Corrosion on thermistor shield, brown corrosion on cable retaining ring
WBOC70 - Clean cell - slight growth on case - brown corrosion on cable retaining ring
Slight hair on current meter rotor, vane and case

1730 - heading for port

1748 - Removing and packing sensors, acoustic release and glass balls:
zinc nearly gone from Paroscientific pressure sensors.

1820 - Disable acoustic release sitting on deck - not clear if worked properly
Restart instrument for trip home.

CONTINUATION OF RECORD FOR SHIPPING HOME

:S:END OF STORAGE

Sample int. ? 11002244

burst int. ? 2244999999

burst length ? 6644

event delay ? 88119922

event limit ? 88119922

event wait ? 88119922

press g G

DM->R

DM->÷? Floating point error FDZ

3.5 sec. record - time 0

nevent 00 evdly 8192 evlim 8192

a/d 209 82C 847 0 0 0 934 0 0

ctd 0000009CE25C481AE6000000
rotor 0 comp. 0 vane 0

time 0
evmask 0060 nsamp 0
pmean 0.000000 pstd 0.000000 spmean 0.000000
obsmeans 0.000000 0.000000

X

mask 88000000

Appendix D:

Dredge Disposal Site Monitor Operations Manual

12 April 93

Dredge system commands

- A** - display last average record.
- C** - display trigger criterion.
- D** - dump data one record at a time in ASCII.
- E** - force event trigger.
- H** - halt system clock.
- N** - write note to storage and restart sampling.
- O** - toggle recorder ON/OFF.
- P** - prepare for deployment - starts sampling.
- Q** - put system to sleep.
- R** - display next 3.5 second record.
- S** - display storage and sampling status.
- W** - toggle WATCH mode to display raw data.
- X** - set event trigger mask.
- Z** - binary memory dump - ONLY TO BE USED BY DUMPDR PROGRAM..
- !** - POWER ON CLEAR - resets to system defaults.

Delayed commands **A**, **R** and **C** are not executed until the next 3.5156 second clock cycle. During a burst, no data can be displayed because of time requirements, and a message will be printed giving the number of samples remaining in burst.

FLAGS:

EVENT FLAG BYTE bits

MSB 7 - forced event active

6 - RESERVED

5 - pressure

4 - rotor

3 - OBS optical sensor

2 - x don't care

1 - x "

0 - x "

TRIGGER MASK WORD bits

MSB 16 - all triggers disabled

15 - UNUSED

14 - "

13 - "

12 - "

11 - "

10 - "

9 - "

8 - "

7 - "

6 - pressure

5 - rotor

4 - UNUSED

3 - OBS #2

2 - OBS #1

1 - UNUSED

0 - UNUSED

ex: 8000 masks all triggers off
000f masks all OBS sensors off
0040 masks pressure off
0020 masks rotor off
0060 masks rotor and pressure off

Definition of terms

Sample int. ? Number of clock intervals in average record. One clock interval is $3600 \text{ sec}/1024 = 3.515625 \text{ sec}$. This is the "normal" recording interval. The DEFAULT = 256 intervals = 15 minutes.

Burst int. ? Number of clock intervals (3.5 sec) between pressure bursts. At the specified interval, the analog pressure sensor will be sampled every 0.87890625 seconds for the number of 3.5156 second clock intervals specified in "burst len." The DEFAULT = 1024 intervals = 1 hour.

Burst length ? Length of burst sample in clock intervals (3.5156 seconds). DEFAULT = 128 intervals = 7.5 minutes (512 samples).

Event delay ? Delay after event time-out is limit reached. Event triggers will not be permitted until the specified number of clock intervals (3.5156 seconds) after an event time-out. Also see "event limit." DEFAULT = 128 intervals = 7.5 minutes.

Event limit ? Maximum duration of an event. If an event persists for longer than the specified number of clock intervals (3.5156 seconds) the event will be terminated and further events not permitted as specified by "event delay". DEFAULT = 128 intervals = 7.5 minutes.

Event wait ? Number of clock cycles (3.5156 second) to prevent event triggers in order to allow trigger criterion to stabilize. DEFAULT = 128 intervals = 7.5 minutes

NOTE: Manual event trigger "COMMAND E" is NOT affected by the above parameters. The manual event will stay on until reset.

When entering these parameters, the previous value can be retained by entering a carriage return. This does not apply to "event wait". For this parameter, a carriage return (or 0) will cause the trigger criterion to remain unchanged. A nonzero value will reset the trigger criterion.

Examples of each command

A - display last average record

```
DM->A
DM->time 15
# samples 16 type 0 a/d data
10165 2614 41 31 60 25978 27364 53404 58387
squares 4140517 295688
rotor 0 comp 8 vane 0 east 0 north 0
ctd endt 55062 press 0 temp 832693 cond 0
```

C - display trigger criterion

```
DM->? C
DM->
evmask 0040 nsamp 4 pmean -.250000 pdstd .750000 spmean 0.000000
obsmeans 1.750000 1.250000
```

D - dump data one record at a time in ASCII

```
DM->? D:M:At BOS
:N:demonstration of commands
:0:000F00000010000000080000000000000000000000000000016D70000000000000B5B40C0000000000
:1:B5270000360A0000290000001F0000003C0000007A650000E46A00009CD0000013E400
:2:009000000027000000230000002A0000001F000000220000001C000000E52D3F000883
:3:04004D00000002D0000009E000000FC G
:D:END OF DATA
```

Clock stopped

E - force event trigger

This command starts an event which remains active until E is entered again. You can check to see if the forced event is in effect by entering R and reading the event flag. The most significant bit denotes a forced event.

H - halt system clock

DM->? H
clock stopped

commands P and N will restart clock.

N - write note to storage and restart sampling

DM->? N
continue ?M:Searching ...
:D:END OF DATA
Message length must be between 5 and 80 characters.
Hit <RETURN> key to terminate.
reset clock

:D:END OF DATA

(In this example the current values were retained by entering carriage returns.)

burst int. ?
Sample int. ?
burst length ?
event delay ?
event limit ?
event wait ?
press g

O - toggle recorder ON/OFF

The recorder is turned on by the P and N commands. It is turned off by the T command.

DM->? O
DM->? S
Sample int.256 burst int 1024 len 512 event delay 128 lim 256 wait 256
Real-Time Monitor OFF
Recorder OFF now it's off
Format Selected Computer

Storage	Position	Used	Total	Left
Bytes	00000187	00000187	00327680	00327493
Records	4	4	~ 7123	~ 7119
File	0	0	--	

DM->? O (it may take a few seconds to find the end of data)
:D:END OF DATA

DM->? S
Sample int.256 burst int 1024 len 512 event delay 128 lim 256 wait 256
Real-Time Monitor OFF
Recorder ON now it's on
Format Selected Computer

Storage Position	Used	Total	Left
Bytes 00000187	00000187	00327680	00327493
Records 4	4	~ 7123	~ 7119
File 0	0	--	

P - prepare for deployment - starts sampling

DM->? P
continue ?Are you SURE (Y/N) ? Y
Initializing Storage ... Done ! this takes a few minutes WAIT
:M:Searching ...
:D:END OF DATA
Message length must be between 5 and 80 characters.
Hit <RETURN> key to terminate.
demonstration of commands

:D:END OF DATA

Sample int. ? 16
burst int. ? 1024
burst length ? 128
event delay ? 256
event limit ? 256
event wait ? 16

press g

Q - put system to sleep - NOT USEFUL IN 1993

The Dredge system automatically goes into a low power "sleep" when the SAIL communications link is disconnect. This command would turn off the sensors and put the system into a sleep mode until the system was wakened by the SAIL communications being present.

R - display next 3.5 second record

? R

DM->

3.5 sec. record - time 3

event 00 evdly 16 evlim 256
ad 1A3 4E 40F 448 858 920 5 1 1
ctd 0000308A1000000806000000
rotor 0 comp. 8 wane 0

S - display storage and sampling status

DM->? S

Sample int.256 burst int 1024 len 512 event delay 128 lim 256 wait 256

Real-Time Monitor OFF

Recorder OFF

Format Selected Computer

Storage Position	Used	Total	Left
Bytes 00000187	00000187	00327680	00327493
Records 4	4	~ 7123	~ 7119
File 0	0	--	

W - toggle WATCH mode to display raw data

DM->? W

DM->? S

Sample int.256 burst int 1024 len 512 event delay 128 lim 256 wait 256

Real-Time Monitor ON now it's on

Recorder ON

Format Selected Computer

Storage Position	Used	Total	Left
Bytes 00000187	00000187	00327680	00327493
Records 4	4	~ 7123	~ 7119
File 0	0	--	

DM->02900174000200010003000F04470459081F090600010002000200010002000100FF
03000800FF
0000708A1000000806200000
028F0175000200020002000F04470458081F090600020002000200020001000200FF
03000800FF
0000808A1000000806200000

? W

DM->? S

Sample int.256 burst int 1024 len 512 event delay 128 lim 256 wait 256

Real-Time Monitor OFF now it's off

Recorder ON

Format Selected Computer

Storage Position	Used	Total	Left
Bytes	00000187	00000187	00327680
Records	4	4	~ 7123
File	0	0	--

X - set event trigger mask - see FLAGS above

DM->? X

mask 40

mask 0040

**Z - dump entire memory in binary - ONLY TO BE USED BY DUMPDR PROGRAM
DO NOT ENTER FROM KEYBOARD!!**

! - system reset - POWER ON CLEAR - resets to system defaults

DOCUMENT LIBRARY

Distribution List for Technical Report Exchange - July 1, 1993

University of California, San Diego
SIO Library 0175C (TRC)
9500 Gilman Drive
La Jolla, CA 92093-0175

Hancock Library of Biology & Oceanography
Alan Hancock Laboratory
University of Southern California
University Park
Los Angeles, CA 90089-0371

Gifts & Exchanges
Library
Bedford Institute of Oceanography
P.O. Box 1006
Dartmouth, NS, B2Y 4A2, CANADA

Office of the International Ice Patrol
c/o Coast Guard R & D Center
Avery Point
Groton, CT 06340

NOAA/EDIS Miami Library Center
4301 Rickenbacker Causeway
Miami, FL 33149

Library
Skidaway Institute of Oceanography
P.O. Box 13687
Savannah, GA 31416

Institute of Geophysics
University of Hawaii
Library Room 252
2525 Correa Road
Honolulu, HI 96822

Marine Resources Information Center
Building E38-320
MIT
Cambridge, MA 02139

Library
Lamont-Doherty Geological Observatory
Columbia University
Palisades, NY 10964

Library
Serials Department
Oregon State University
Corvallis, OR 97331

Pell Marine Science Library
University of Rhode Island
Narragansett Bay Campus
Narragansett, RI 02882

Working Collection
Texas A&M University
Dept. of Oceanography
College Station, TX 77843

Fisheries-Oceanography Library
151 Oceanography Teaching Bldg.
University of Washington
Seattle, WA 98195

Library
R.S.M.A.S.
University of Miami
4600 Rickenbacker Causeway
Miami, FL 33149

Maury Oceanographic Library
Naval Oceanographic Office
Stennis Space Center
NSTL, MS 39522-5001

Library
Institute of Ocean Sciences
P.O. Box 6000
Sidney, B.C. V8L 4B2
CANADA

Library
Institute of Oceanographic Sciences
Deacon Laboratory
Wormley, Godalming
Surrey GU8 5UB
UNITED KINGDOM

The Librarian
CSIRO Marine Laboratories
G.P.O. Box 1538
Hobart, Tasmania
AUSTRALIA 7001

Library
Proudman Oceanographic Laboratory
Bidston Observatory
Birkenhead
Merseyside L43 7 RA
UNITED KINGDOM

IFREMER
Centre de Brest
Service Documentation - Publications
BP 70 29280 PLOUZANE
FRANCE

REPORT DOCUMENTATION PAGE	1. REPORT NO. WHOI-93-43	2.	3. Recipient's Accession No.
4. Title and Subtitle Deployment of a Bottom Monitor at a 30 Meters Deep Site in the New York Bight Apex During the Summer of 1993		5. Report Date September 1993	
7. Author(s) James D. Irish		6.	
9. Performing Organization Name and Address Woods Hole Oceanographic Institution Woods Hole, Massachusetts 02543		8. Performing Organization Rept. No. WHOI-93-43	
12. Sponsoring Organization Name and Address National Oceanic and Atmospheric Administration and the U.S. Army Corps of Engineers, New York District		10. Project/Task/Work Unit No.	
15. Supplementary Notes This report should be cited as: Woods Hole Oceanog. Inst. Tech. Rept., WHOI-93-43.		11. Contract(C) or Grant(G) No. (C) (G)	
16. Abstract (Limit: 200 words) A bottom instrument was deployed on May 5, 1993, recovered and redeployed on June 22, 1993 and finally recovered on July 28, 1993 at a 30 meter site in the New York Bight Apex. The instrument measured currents, suspended sediment concentrations, pressure, temperature and conductivity. The data storage was filled in only seven days on the first deployment as in 18 days in the second. The averaging sampling process worked well, producing hourly (first deployment) and half hourly (second deployment) values of all sensors and instrument internal diagnostics to obtain background environmental information. The burst sampling scheme sampled once a day for waves, and identified 6 and 10 second waves present. The event sampling scheme was tested for the first time. During deployment one, high frequency pressure signals were allowed to trigger events, and bad cabling caused excessive events to be recorded, filling the memory prematurely. For deployment two, only the optical sediment sensors were allowed to trigger events, and 146 events were recorded. Many of the events were only seen in one or the other optical sensor and probably associated with fish or floating debris. Other events had unique signatures, one type possibly due to passing ships.		13. Type of Report & Period Covered Technical Report	
17. Document Analysis a. Descriptors New York Bight sediment transport bottom monitoring instrumentation		14.	
b. Identifiers/Open-Ended Terms		15.	
c. COSATI Field/Group		16.	
18. Availability Statement Approved for public release; distribution unlimited.	19. Security Class (This Report) UNCLASSIFIED	21. No. of Pages 90	
	20. Security Class (This Page)	22. Price	

